



**INSTALLATION, OPERATION, AND
MAINTENANCE MANUAL**

**MFS MID 20-72
MX II CONTROLLER**

**SINGLE
COMMERCIAL
WATER FILTERS**

FILL IN FOR FUTURE REFERENCE

MODEL NO:
SERIAL NO:
DATE INSTALLED:
DEALER:

Marlo Incorporated
2227 South Street
P.O. Box 044170
Racine, WI 53404-7003
Ph. (262) 681-1300
Fax (262) 681-1318
www.Marlo-Inc.com

INSTALLATION WARNING

PRIOR TO Media Loading

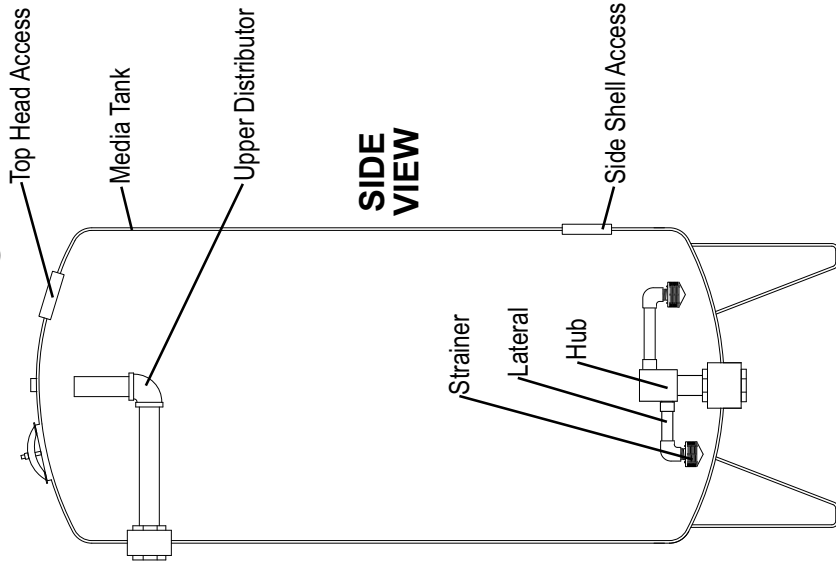

Inspection Requirement Prior to Loading Media

1. Inspect condition of upper distributor piping. Verify fittings are tight and positioned as shown.
2. Inspect condition of strainers, laterals and hub through top or side access ports. Verify fittings are secured to hub and strainers are secured to laterals.
3. **DO NOT** load media if damaged components are observed. Contact factory.
4. Installer is responsible for media loss into treated water resulting from failure to report and repair damaged components inside media tank prior to media loading.
5. **INSTALLER WARNING:**
Refer to installation instructions for media loading procedure. Improper loading of media will damage components inside media tank.

AFTER Media Loading

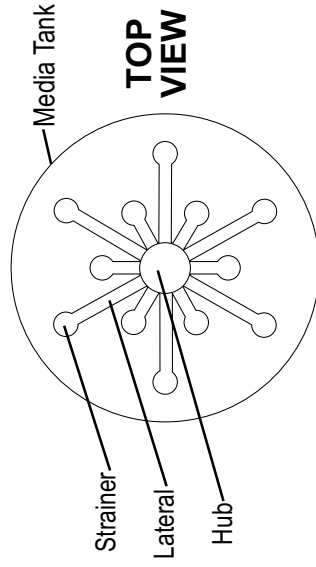
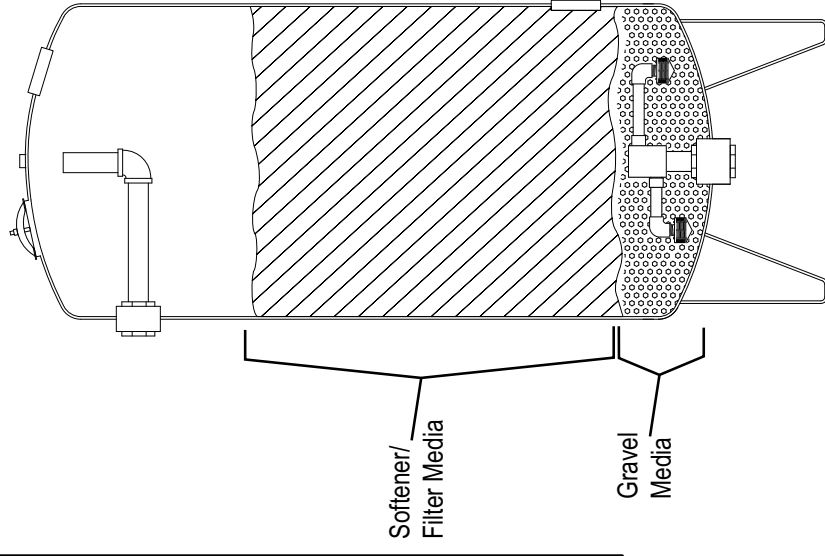

TABLE OF CONTENTS

Product Warranty and Water Media Guarantee.....	1
General Layout Drawing.....	2
Specification Table	3
Filter Installation Instructions	4
Piping Installation	4
Control Tubing Installation.....	5
Control Tubing Diagram	5
Wiring Installation	6
Filter Tank Loading	7
Start-Up Procedure	8
Water Filter General Operation	13
Flow Diagram	13
Programming Guide	14
Trouble Shooting the Stager.....	17

Appendix:

- Aquamatic Diaphragm Valves

WATER TREATMENT PRODUCT WARRANTY

Marlo, Inc. warrants all water treatment products manufactured and/or distributed by it to be free from defects in materials and workmanship for a period of one (1) year from the date of shipment. If within that period any products shall be proven to Marlo, Inc.'s satisfaction to be defective, those products will be replaced, or the price refunded at Marlo Inc.'s option.

Marlo Inc.'s obligations or nonperformance, defective, or any damage caused by its products or their use, and buyer's exclusive remedy therefore, shall be limited to product replacement or refund and shall be conditioned upon Marlo Inc.'s receiving written notice together with a demand for such replacement or refund:

The foregoing warranty is exclusive and in lieu of all other expressed implied warranty (except of title) including but not limited to implied warranty of merchantability and fitness for particular purpose.

Marlo Inc. will not be subject to and disclaims the following:

1. Any other obligations or liabilities arising out of breach of contract or out of warranty.
2. Any obligations whatsoever arising from tort claims (including negligence and strict liability) or arising under other theories of law with respect to products sold or services rendered by Marlo Inc. or any undertakings, acts, or omissions relating thereto.
3. All consequential, incidental, and contingent damages.

Labor charges, change backs or handling charges are excluded from Marlo Inc.'s warranty provisions.

WATER MEDIA GUARANTEE

Under normal operating conditions:

1. The loss of filter media through attrition during the first three (3) years shall not exceed 3% per year.
2. The filter media shall not be washed out of the system during backwash.
3. The color and turbidity of the effluent shall not be greater than the incoming water.

Any mechanical equipment proving defective in workmanship or material within one year after installation or eighteen (18) months after shipment, whichever comes first, shall be replaced FOB factory.

GENERAL ARRANGEMENT DRAWING

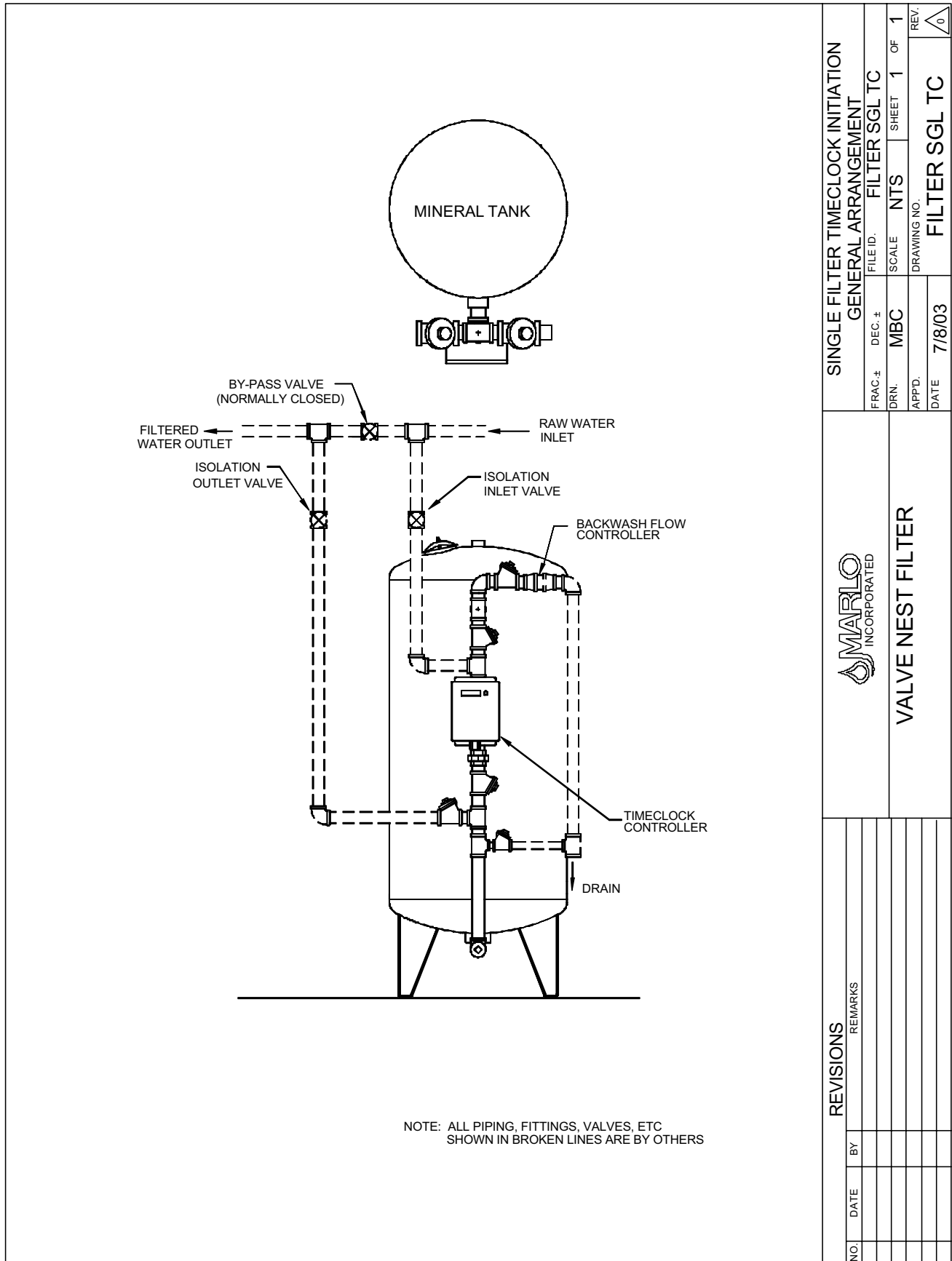

		SINGLE FILTER TIMECLOCK INITIATION	
		GENERAL ARRANGEMENT	
FRAC. #	DEC. #	FILE ID.	FILTER SGL TC
DRN.	MBC	SCALE	NTS
APP'D.		DRAWING NO.	1 OF 1
DATE	7/8/03		FILTER SGL TC
REVISIONS			
NO.	DATE	BY	REMARKS



MFS MID 20-72 SINGLE FILTER MX-II

SPECIFICATION TABLE

Model	SERVICE FLOW RATE						BACKWASH FLOW RATE GPM	PIPE SIZE inches	TANK SIZE inches	FLOOR SPACE inches	HEIGHT inches
	EXCELLENT		HIGH		UTILITY						
	GPM	.P	GPM	.P	GPM	.P					
MID-20	25	4	35	7	50	12	30	1 1/2	20x54	21x30	72
MID-24	30	4	50	10	65	17	45	1 1/2	24x54	25x34	73
MID-30	50	6	75	13	98	18	75	2	30x54	31x40	76
MID-36	71	5	106	9	141	15	105	2 1/2	36x60	37x48	89
MID-42	97	7	145	12	192	20	150	2 1/2	42x60	43x54	94
MID-48	126	5	189	11	251	17	180	3	48x60	49x62	88
MID-54	159	7	239	14	318	19	240	3	54x60	55x70	89
MID-60	198	10	295	19	393	30	300	3	60x60	60x76	90
MID-66	240	5	360	17	480	25	360	4	66x60	67x86	105
MID-72	285	5	425	8	575	12	420	4	72x60	73x92	95

MODEL	ANTHRACITE	RED SAND	GARNET 30-40	GARNET 8-12	GRAVEL
MID-20	112	150	150	100	100
MID-24	168	250	200	150	200
MID-30	280	350	350	250	300
MID-36	392	550	550	350	400
MID-42	532	700	750	500	600
MID-48	728	950	1000	650	900
MID-54	896	1200	1250	800	1200
MID-60	1120	1500	1500	950	1500
MID-66	1344	1800	1850	1150	2000
MID-72	1624	2100	2150	1350	2500

All values are in pounds

VOLUME VERSES WEIGHT OF MEDIA

Anthracite "C"	56# per Cu. Ft.	1 Cu. Ft. per bag
Red Sand	100# per Cu. Ft.	100# per bag
Garnet 30-40	130# per Cu. Ft.	50# per bag
Garnet 8-12	140# per Cu. Ft.	50# per bag
Gravel	100# per Cu. Ft.	100# per bag

NOTE: Bag size may vary. Please confirm weight and volume before loading. Consult Media sheet on media pallet.

Power Requirements 120 Volt, 60 Hertz, Single Phase, 2A
 Operating Pressure Range: 30 - 100 psig
 Operating Temperature Range: 35 - 100 F

INSTALLATION INSTRUCTIONS

Before beginning installation, thoroughly review the following instructions to familiarize yourself with the general placement and identification of all components.

These instructions are written for a single unit installation, but they also generally apply to twin and triple units.

The operating pressure range is 30 - 100 psi. Water pressures not meeting these specifications should have a booster pump installed for pressure lower than 30 psi and a pressure regulator installed for pressure exceeding 100 psi.

The operating temperature range is 35-100°F. Special filters are available to handle higher temperature ranges. Consult factory for recommendations.

Catalog filters are shipped fully assembled with face piping and controllers. Care must be taken not to damage valves or controllers during uncrating and installation.

FILTER LOCATION

Select a position near a floor drain that has adequate carrying capacity to handle the water filter backwash rate. See the Specification Table located on page 3 for the backwash rate of your system.

Make sure the softeners are placed on a level concrete surface.

PIPING INSTALLATION

Install piping as shown on the general arrangement drawing. Include unions and shut-off valves on the inlet and outlet of each tank. It is recommended that a union be installed in each filter drain-line to facilitate cleaning the backwash flow control.

Note: Do not reduce drain-line pipe size. Do not install a shut off valve in the drain-line. Provide an air gap in the drain line in accordance with local codes (minimum: four (4) pipe diameters).

On installations with a differential pressure switch, the ¼" male tube fitting connectors must be installed in the main inlet and outlet headers as shown on the general arrangement drawing. After the piping has been completed, make sure to close all isolation valves.

CONTROL TUBING INSTALLATION

Refer to the control-tubing diagram for your filter.

On single and skid mounted units the factory does the control tubing.

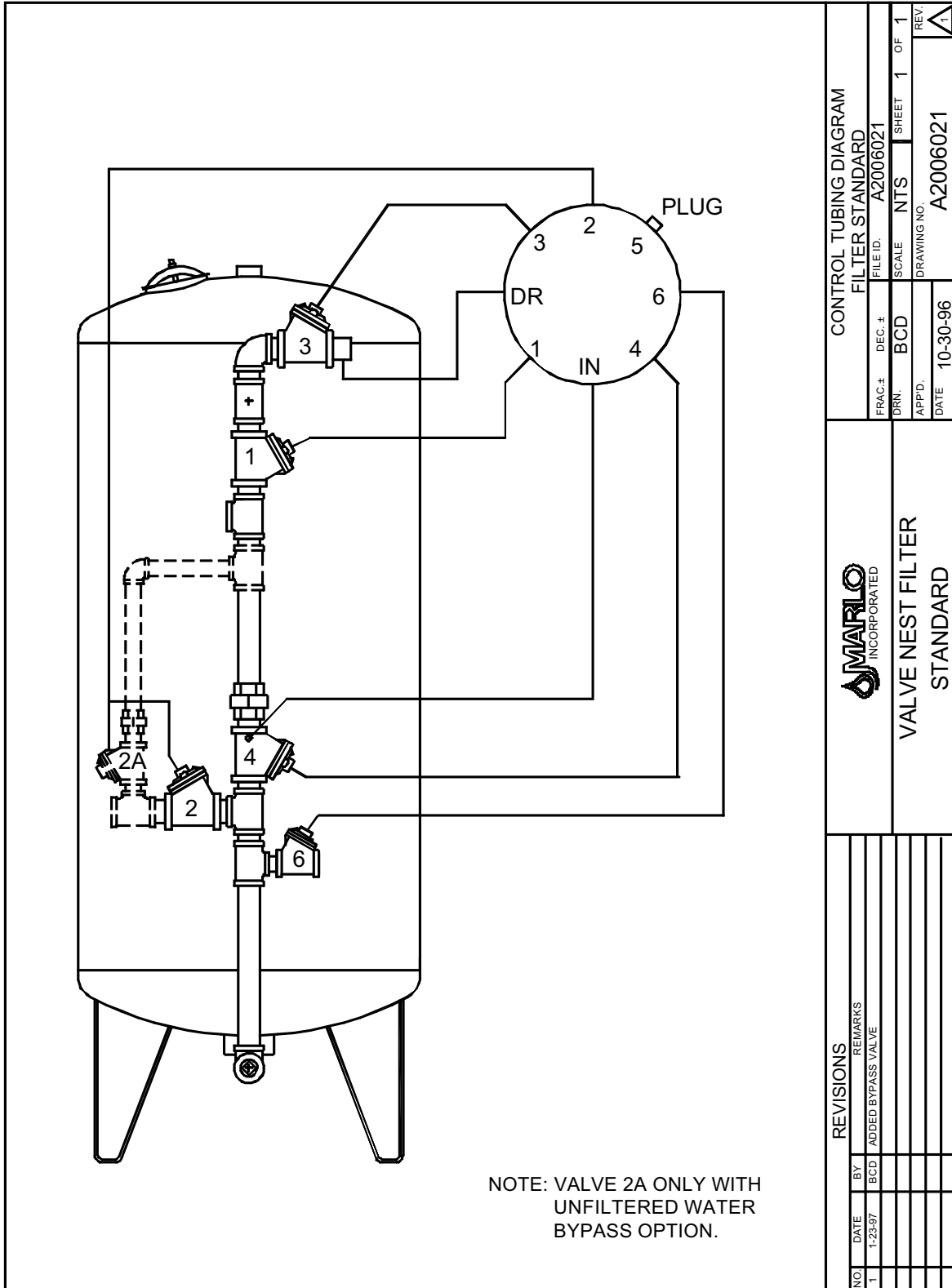

		VALVE NEST FILTER STANDARD	
CONTROL TUBING DIAGRAM FILTER STANDARD			
FRAC.#	DEC. #	FILE ID.	SHEET 1 OF 1
DRN.	BCD	SCALE	NTS
APP'D.	DATE	DRAWING NO.	REV.
	10-30-96	A2006021	1
REVISIONS			
NO.	DATE	BY	REMARKS
1	1-23-97	BCD	ADDED BYPASS VALVE

FILTER TANK LOADING

GRAVEL LOADING

Before loading, visually check the lower distributor for shipping damage. All radial arms and baskets strainers are in place and pointing downward. Tighten any loose laterals. Do **not** load tank if there is damage is evident. Call the factory if any damage is observed.

Do begin to load the tank until you have verified that all required gravel and filter media is on site. Refer the media loading table on page 3 for the required amounts.

1. Slowly open the inlet valve and fill the tank half way or as full as possible with water. There might be a flow of water to drain.
2. The equipment provided has a plastic lower distributor system. Care should be exercised in the loading of the gravel in order to insure that the distributors are not damaged.
3. Slowly and gently pour the gravel marked for the mineral tank into the unit.
4. Drain the tank down until the gravel and water levels are the same.
5. Carefully level the gravel before loading the resin.

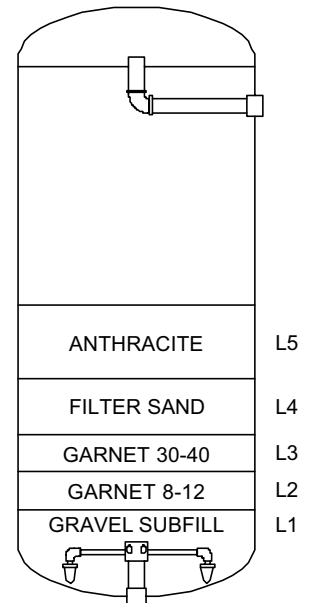

MEDIA LOADING

1. Reopen the inlet valve and fill the tank with water approximately 6" above the present media level.
2. Pour the quantity of L2 media specified for the unit in through the top opening and then level the layer of media.
3. Repeat steps 1 and 2 until all five layers (L3, L4, L5) of media are loaded.
4. Reopen the inlet valve and fill the tank with water to the top access opening. Close and secure the top access opening.
5. Open inlet valve and continue to fill the tank with water until it is fully pressurized.

START-UP INSTRUCTIONS

Before proceeding to start-up:

- ◆ Make sure the unit is properly installed with all piping complete
- ◆ All of the required media has been properly loaded in the tank
- ◆ Read the controls section located in this manual

1. Open the manual by-pass valve. The manual inlet and outlet valves are to remain closed.
2. Connect the power to the MX II controller. The controller display window will light up.
3. Verify the following and change if required.
SINGLE TIME CLOCK is displayed in the window
4. Open the cover of the enclosure on and manually rotate the stager to the #1 (BACKWASH) position. The stager motor will rotate back to the #4 (SERVICE) position. This is done to confirm the controller's homing signal is operational.
5. Press and hold the **MANUAL START** button on the front of the controller. This will advance the controller to the backwash step. The stager should rotate to the step 1 (BACKWASH) position.
6. Slowly open the softener's manual inlet supply valve. Do not open fully. Full flow of water could cause loss of media. Continue to fill slowly until all air is expelled and only water flows to the drain. Water will enter from the bottom of the resin tank as air is expelled from the top drain. If the system is supplied with an air vent make sure that the valve is open during this process.
7. When only water flows to the drain and out the air vent (if applicable), open the manual inlet valve all of the way. Backwash until the water looks clean when caught in a container.
8. Advance the controller to the brine/slow rinse step by pressing and holding the **ADVANCE** button. The stager should rotate to the STEP 2 (BRINE/SLOW RINSE) position. There will be a slow flow to the drain.
9. While the stager is in the Brine/Slow Rinse position, check the level in the brine tank. The level should be dropping at a slow rate (approximately 2" per minute).

10. Advance the controller to the Fast Rinse position. The Unit 1 stager should rotate to the STEP 3 (FAST RINSE) position. There will be a high flow of water to the drain. Allow the water to flow to the drain until clear. During this time, the brine tank will fill with water until the float closes the brine tank valve. Check that all brine fittings are tight and that the water level in the brine tank is according to the unit specifications.
11. Advance the controller to the service position. The stager should rotate to the STEP 4 (SERVICE) position. There will be no flow of water to the drain.
12. Fill the brine tank with the proper amount and type of salt recommended for use with the system. See RECOMMENDED TYPES OF SALT.
13. Close the manual by-pass valve and open all outlet valves fully. The system is now in service.

WATER FILTER GENERAL OPERATION

Raw water passes through the valve manifold into the top of the tank. It flows downward through the mineral bed and out through the bottom of the tank to service. As the water passes through the mineral bed, sediment present is removed by filtration action of the mineral.

The media must be cleaned periodically by the following procedure:

Backwash: The flow through the mineral bed is reversed and allowed to flow to drain. The up-flow action washes any sediment or foreign material collected in the unit out to drain. At the same time the mineral itself is restratified, thereby eliminating any possibility of channeling (approximately 10 minutes).

Settle: The media is allowed to settle in a stratified manner.

Fast Flush: The downward flow to drain in this step is increased to a high rate, which will repack the media bed.

FLOW DIAGRAM

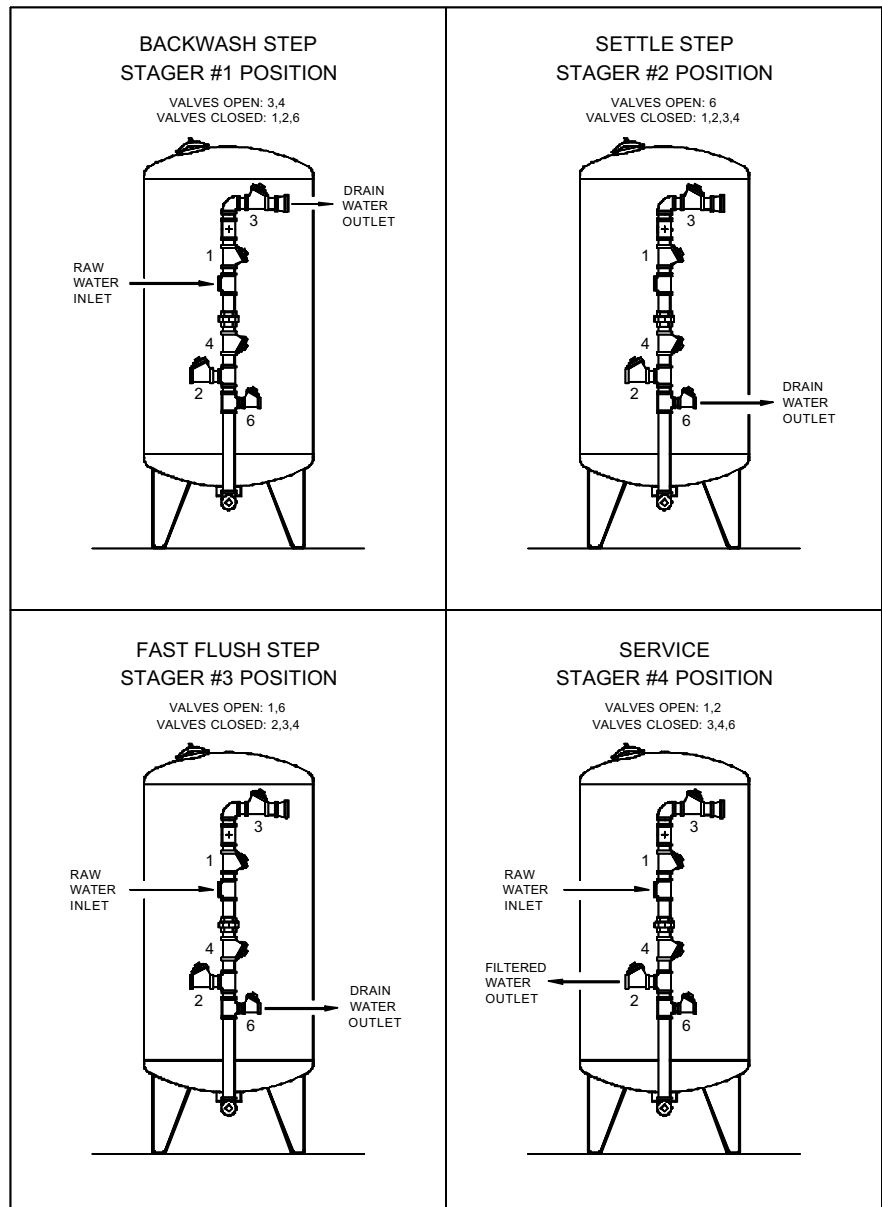

Program Guide - Single Filter MXII

NOTE: Steps must be performed within 30 seconds of each other or the controller will exit programming mode.

BEGINNING FROM FACTORY DEFAULT

NOTE: To get to Factory Default press & hold “MANUAL START and ” keys until the display reads “Factory Default”.
Ignore “Press ENTER to Program”

STEP 1

↓SYSTEM TYPE

MANUAL START



ADVANCE

ENTER

◀ ▶

▲

▼

A. Press   keys simultaneously for 3 seconds to enter program mode.

B. “↓SYSTEM TYPE” appears. Press .

STEP 2

SYSTEM TYPE

↓SOFTENER

MANUAL START



ADVANCE

ENTER

◀ ▶

▲

▼

A. “↓SOFTENER” appears; If “↓FILTER” is not displayed, use   keys until it is.

B. Press  to choose FILTER.

NOTE: If you toggle to “FILTER” then back to “SOFTENER”, press “ENTER” key until only “↓SYSTEM TYPE” appears on top line with nothing displayed on the second line.

STEP 3

↓SYSTEM TYPE

MANUAL START

ADVANCE

ENTER

◀ ▶

▲

▼

A. “↓SYSTEM TYPE” appears.

B. Press .

STEP 4

SYSTEM MODE

↕SINGLE TIME CLOCK

MANUAL START

ADVANCE

ENTER



◀ ▶

▲

▼

A. “↕SYSTEM MODE” appears.

B. Press .

C. Use  or  to scroll to “↕SINGLE TIME CLOCK”. The screen shown here is displayed.

D. Press  to choose SINGLE TIME CLOCK.

E. If necessary, Press  again until the display is as shown below.

Program Guide - Single Filter MXII

STEP 5

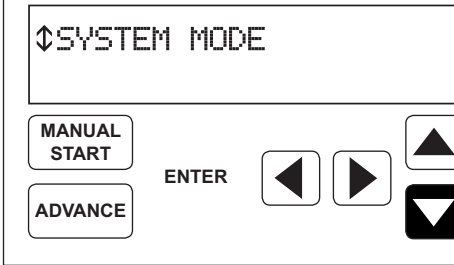

- A. "⇄SYSTEM MODE" should be displayed on the top line, with nothing displayed in the second line.
 B. Press .

STEP 6

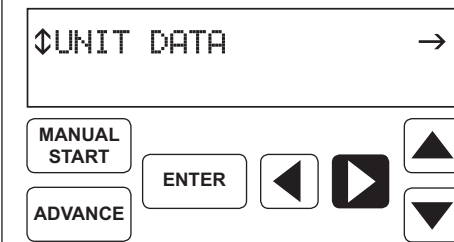

- A. "⇄UNIT DATA" appears.
 B. Press .

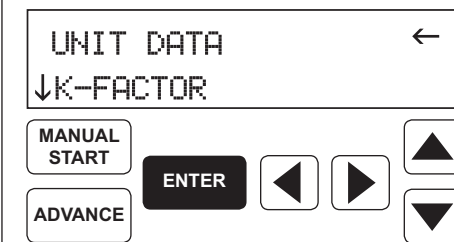

STEP 7

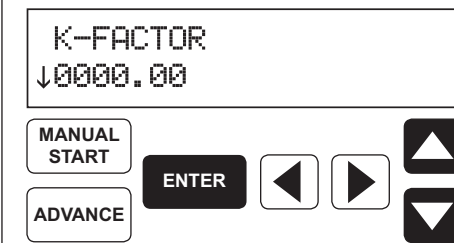

- A. "↓K-FACTOR" appears.
 B. Press .

STEP 8



- A. Use   keys to enter K-FACTOR value.
 B. Press  until the next display in step 9 is shown.

STEP 9

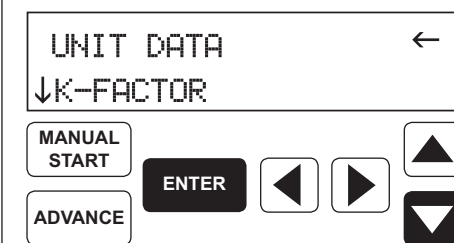

- A. "↓K-FACTOR" appears.
 B. Press .

Program Guide - Single Filter MXII

STEP 10

UNIT DATA
 ↑UNIT #

A. "↑UNIT #" appears on second line.

B. Press .

STEP 11

UNIT #
 ↑1

A. "UNIT #" appears on top line with the unit's # displayed on second line.

B. Use to scroll to unit (1).

C. Press until the next display in step 12 is shown.

STEP 12

UNIT DATA
 ↑UNIT #

A. Press .

B. "↓UNIT DATA" appears by itself on top line.

C. Press .

STEP 13

↓CYCLES

A. "↓CYCLES" appears.

B. Press .

C. "↓CYCLE 1 NAME" appears on second line.

STEP 14

CYCLE 1 NAME
 BACKWASH

A. Press to choose cycle name (BACKWASH) to appear instead of CYCLE #. 'BACKWASH' is displayed on the second line.

B. Press until the display in step 15 is displayed.

Program Guide - Single Filter MXII

STEP 15

CYCLES ←

↓CYCLE 1 NAME

MANUAL START

ADVANCE

ENTER

←
→
↑
↓

A. "↓CYCLE 1 NAME" appears on second line.

B. Press . "CYCLE 1" appears.

C. Press .

STEP 16

CYCLE 1

0016 MINS

MANUAL START

ADVANCE

ENTER

←
→
↑
↓

A. "CYCLE 1" appears on the first line. "0016 MINS" appears on the second line.

B. Use arrow keys to dial in time of cycle.

C. Press until the screen in step 17 is displayed.

STEP 17

CYCLES ←

↓CYCLE 1

MANUAL START

ADVANCE

ENTER

←
→
↑
↓

A. Press .

B. "↓CYCLE 2 NAME" appears on second line.

STEP 18

CYCLES

↓SETTLE

MANUAL START

ADVANCE

ENTER

←
→
↑
↓

A. Press . "↓SETTLE" appears.

B. Press until the screen in step 19 is displayed.

STEP 19

CYCLES ←

↓CYCLE 2 NAME

MANUAL START

ADVANCE

ENTER

←
→
↑
↓

A. Press . "CYCLE 2" appears on second line.

B. Press .

Program Guide - Single Filter MXII

STEP 20

CYCLE 2
0004

- A. "CYCLE 2" appears on top line. "0004 MINS" appears on second line.
- B. Use arrow keys to dial in number.
- C. Press until the screen in step 21 is displayed.

MANUAL
START

ENTER

ADVANCE



STEP 21

CYCLES
↕CYCLE 2

- A. "CYCLES" appears on first line. "↕CYCLE 2" appears on second line.
- B. Press . "↕CYCLE 3 NAME" appears on second line.

MANUAL
START

ENTER

ADVANCE

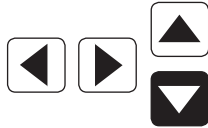

STEP 22

CYCLE 3 NAME
↕FLUSH

- A. Press .
- B. Use to choose the name "FLUSH".
- C. Press until the screen in step 23 is displayed.

MANUAL
START

ENTER

ADVANCE



STEP 23

CYCLE
↕CYCLE 3 NAME

- A. Press . "↕CYCLE 3" appears on the second line.
- B. Press .

MANUAL
START

ENTER

ADVANCE



STEP 24

CYCLE 3
0006 MINS

- A. Dial in minutes using arrow keys.
- B. Press until "↕CYCLE 3" is displayed on second line.
- C. Press .

MANUAL
START

ENTER



ADVANCE

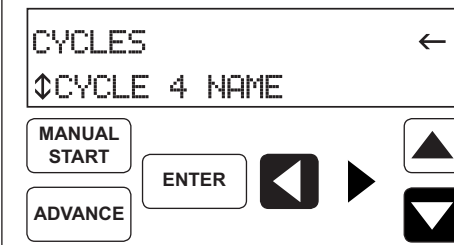

Program Guide - Single Filter MXII

STEP 25



- A. "↓CYCLE 4 NAME" appears on second line.
- B. Press . "↓CYCLES" appears alone on first line.
- C. Press .



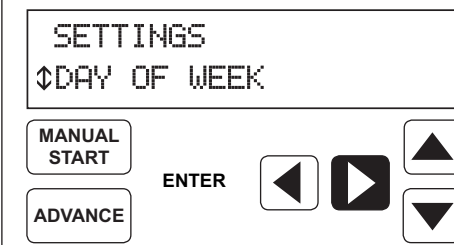

STEP 26

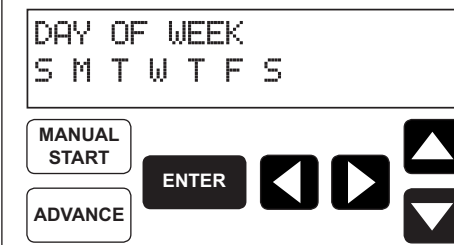

- A. "SETTINGS" appears.
- B. Press .
- C. "DAY OF WEEK" appears on second line.



STEP 27



- A. Press .
- B. Press  or  to cycle through the days of the week to regenerate.
- C. Press  or  to select or turn on the day of the week to regenerate the filter.

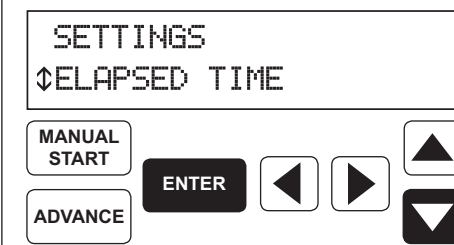



STEP 28

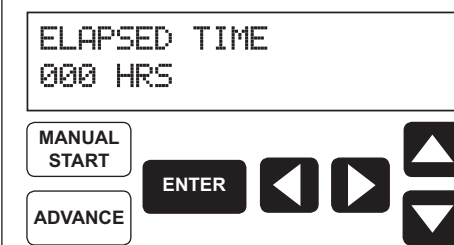

- A. Press  to save.
- B. Press  to exit.
- C. Press  until "ELAPSED TIME" is displayed.

STEP 29



- A. Press .
- B. Press , , ,  to enter the amount of HRS that must pass before the filter will regenerate.

NOTE: All zeros will disable this feature.

Program Guide - Single Filter MXII

STEP 30

SETTINGS

↓BW/REGEN TIME

MANUAL START

ADVANCE

A. Press  to save.

B. Press  to exit.

C. Press  until "BW/REGEN TIME" is displayed.

D. Press  .





STEP 31

BW/REGEN TIME

02:00 A

MANUAL START

ADVANCE

A. Press     to change the regen time.

B. Press  to save.

D. Press  to exit.

NOTE: Default time is 2 AM.

STEP 32

↓UNIT OF MEASURE

MANUAL START

ADVANCE

A. Press  until "SETTINGS" appears on the first line.

B. Press  to get out of "SETTINGS".

C. Press  until "↓UNIT OF MEASURE" appears.



STEP 33

UNIT OF MEASURE

↓FLOW

MANUAL START

ADVANCE

A. Press . "↓FLOW" appears on the second line. If not, press  until "↓FLOW" appears on the second line

B. Press  .

STEP 34

FLOW UOM



↑GPM

MANUAL START

ADVANCE

A. "FLOW UOM" appears on the first line and "↑GPM" appears on the second line.

B. Press  .

C. Press , then , and finally  to exit. Programming is finished and display will return to normal.

SERVICE CHART WATER SOFTENERS continued

When the unit detects a fault, the red alarm LED will display and the detected error will be displayed.

Communication Error	ERROR MESSAGE-	CAUSE
	COMM FAILURE MASTER	No Unit is programmed as Unit 1 - the Master
	COMM FAILURE UNIT 2	A faulty cable or a bad connection with the COM jack Multiple units programmed with the same UNIT# . UNIT# is different from MODE selected.

Program Error	ERROR MESSAGE-	CAUSE
	MODE ERROR UNIT 2	Unit 2 is programmed in a mode different from the Master - Unit 1.
	AUX RELAY SP ERROR	Aux Relay Start time is programmed to a value other than 0 and the Aux Relay Stop time is not greater than the Aux Relay Start time

Drive Motor Error	ERROR MESSAGE-	CAUSE
	DRIVE FAILURE	Faulty motor wiring to terminal strip or terminal block on circuit board Faulty switch on the stager

RESET

Soft Reset – Press the reset button located on the circuit board
Hard Reset – Press and hold the MANUAL START and DOWN arrow for five seconds until UNIT displays the following text:
FACTORY DEFAULT HIT ENTER TO PROGRAM

Press ENTER to restore controller to default settings

AquaMatic® Product Specifications Metal Diaphragm Valves

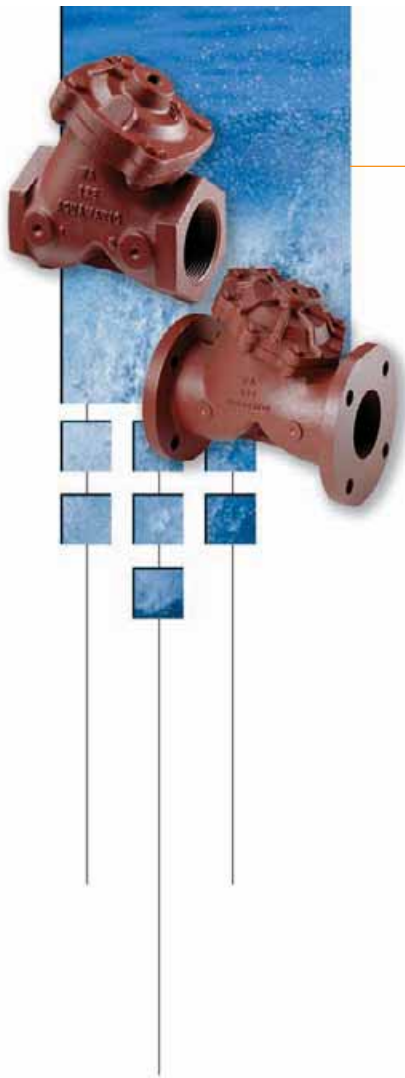

■ Features and Options

- **Low Pressure Loss** The AquaMatic Y-pattern diaphragm valve features a large seat opening and high lift-disc for higher flow rates at a lower pressure loss than other comparable valves
- **Positive Control** A separate valve flow and control chambers permits positive sealing without springs. The optional spring-assist open feature is available for low pressure and self-draining applications.
- **Cost Effective** The AquaMatic is a cost-effective solution both in initial cost, as well as lifetime maintenance expenses.
- **Long Diaphragm Life** Separate diaphragm chambers protects the diaphragm from the flow stream, while allowing the valve to be serviced in-line.
- **Durable Construction** The valve is constructed of cast iron, brass, stainless steel and Nitrile elastomer components, giving an unparalleled service life of three years or longer depending on the application's environment.
- **Design and application engineering service**
- **Optional seal and diaphragm materials for special applications**
- **Handles liquid and gases**
- **Adaptable to wide variety of control devices**
- **Optional adjustable flow rate control**
- **Optional spring assist**
- **Optional position indication**
- **Optional all stainless internals (3" and 4" sizes only)**

■ Principles of Operation

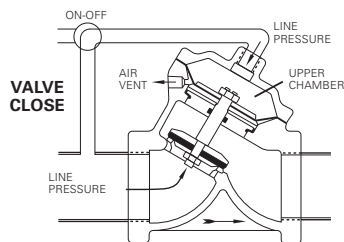

Drip-Tight Closing: Closure is obtained by directing line pressure or equivalent independent pressure into the upper chamber. This pressure on the large diaphragm area causes the valve disc to seal against the seat. (Ratio of diaphragm to disc area is 1.3 or greater.)

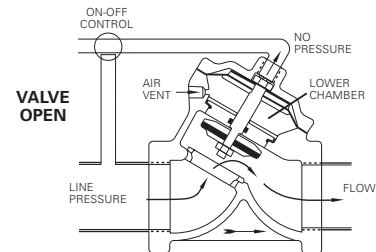

Full Open Operation: When closing pressure in upper chamber is relieved by venting the pilot line, the valve opens, positively, by line pressure on the disc.

■ Applications

In addition to the water treatment process systems, the valves are used in a wide variety of applications. Some of the typical applications are:

- Concrete Additive
- Agricultural Irrigation
- Turf Irrigation
- Air Dryers
- Pump Controls
- Fuel Handling
- Cooling Towers
- Level Control Systems
- Sand Blasting
- Car Wash Systems
- Process Water Systems
- Laundry Equipment
- Conveyor Systems
- Air Control Systems
- Dust Suppression
- Plastic Molding
- Machinery
- Nitrogen Handling
- Vacuum Control Systems
- Machine Hydraulic
- Cooling Control
- Street Cleaning Vehicles
- Centrifugal Separators
- HVAC Systems

Series 420 Valves

Standard valves are normally open. Body and cap are of cast iron. Preformed stress-relieved diaphragm of Nitrile (Buna N) on Polyamide, and static seals are Nitrile, stainless steel and brass internal parts.

Pipe sizes are 3/4 to 3-inch threaded (N.P.T. or B.S.P.); 3-inch through 6-inch flanged drilled in accordance with ASA16.1 class 125, or BSP4504.

Options

Normally closed, spring assist closed, spring assist open, limit stop, position indicator, high temperature service, brass body and cap (3/4 to 3-inch only), optional seal and diaphragm materials for special application, stainless steel internal parts.

Operating Specifications

Working Pressure.....125 PSI (8.6 bar)
 Maximum Temperature150°F (65°C)
 250°F (120°C) – Optional

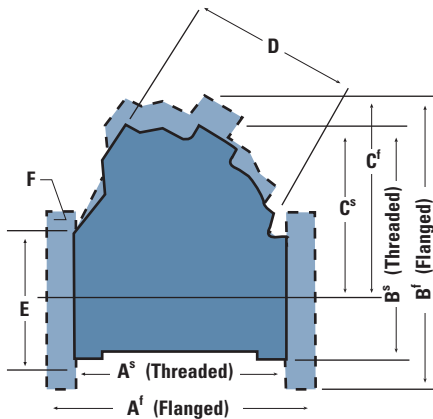

Series VAV Air Valves

Standard valves are normally open. Body and cap are of cast iron. Preformed stress-relieved diaphragm of Nitrile (Buna N) on Nylon, and static seals are FKM & Hycar, stainless steel and brass internal parts.

Pipe sizes are 3/4 to 3-inch threaded (N.P.T. or B.S.P.); 3 to 4-inch flanged drilled in accordance with ASA16.1 class 125, or BSP4504.

Options

Normally closed, spring assist closed, spring assist open, FKM diaphragm for high temperature service.

Operating Specifications

Working Pressure.....125 PSI (8.6 bar) maximum
 Temperature150°F (65°C)
 250°F (120°C) – Optional

Metal Body Valves

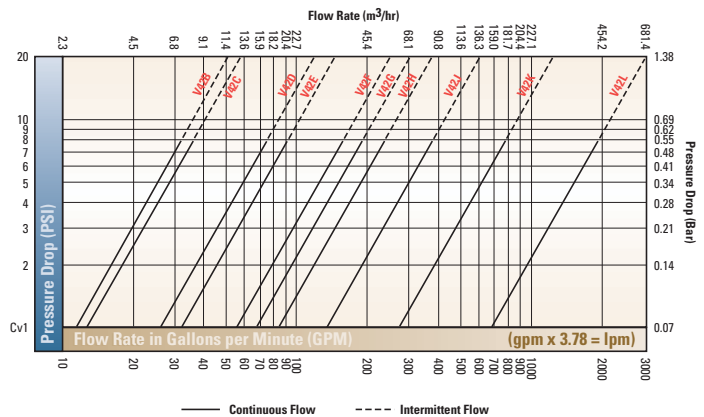

Flow Thru Metal Diaphragm Valves

	Pipe Size	Model Number			Unit	Dimensions (Approximate)										
		420 Series	VAV Series	CV (3)		A ^s	A ^f	B ^s	B ^f	C ^s	C ^f	D	E(1)	F(2)		
Threaded	3/4"	V42B	VAVB	11.4	in.	3.69			4.25			3.75		2.75		
	1"	V42C	VAVC	12.8	mm	94			108			95		70		
	1-1/4"	V42D	N/A	26.5	in.	4.75			5.37			4.00		3.50		
	1-1/2"	V42E	VAVE	32.5	mm	121			137			102		89		
	2"	V42F	VAVF	56	in.	6.62			7.25			5.37		4.87		
	2"	V42G	VAVG	68	mm	168			184			137		124		
	2-1/2"	V42H	VAVH	84	in.	7.37			8.00			5.75		5.50		
Flanged	3"	V42J	VAVJ	134	in.	9.00			9.75			6.75		7.25		
	3"	V42J	VAVJ	134	mm	229			248			171		184		
	3"	V42J	VAVJ	134	in.	mm		10.62		10.75		7.00	7.25	6.00	0.75	
Flanged	4"	V42K	VAVK	275	in.	mm		270		273		178	184	152	19	
	4"	V42K	VAVK	275	in.	mm		298		375		254	222	191	19	
	6"	V42L	N/A	680	in.	mm		432		483		343	402	241	2	

(1) Bolt circle diameter

(2) Bolt hole diameter

(3) CV = Flow rate in gpm of water at 60°F @ 1psi pressure drop

For More Information:

Contact the **Residential and Commercial Group** at **(815) 964-9421** or **(800) 245-9421** or visit **www.gewater.com**

DIAPHRAGM VALVE CONFIGURATIONS - STANDARD MODEL

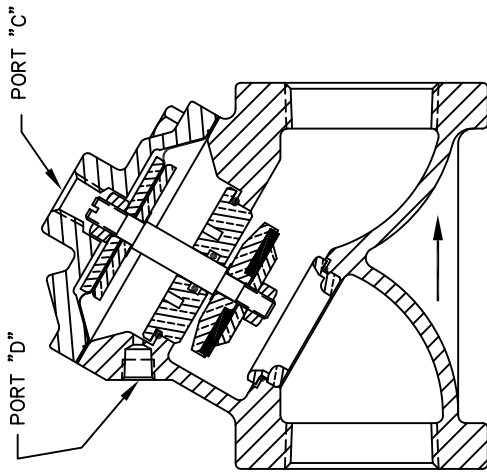

NORMALLY OPEN

LINE PRESSURE/FLOW AGAINST THE VALVE SEATING DISC WILL OPEN THE VALVE. CONTROL PRESSURE APPLIED TO THE TOP OF THE DIAPHRAGM (PORT "C") WILL CLOSE THE VALVE.

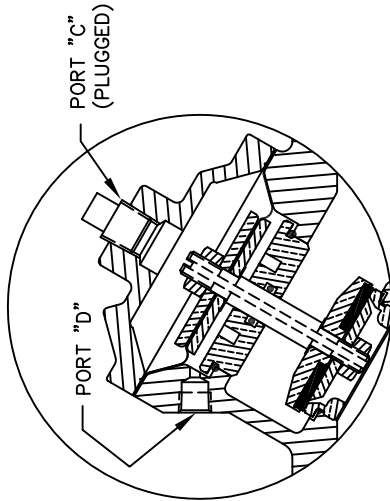

NORMALLY CLOSED

LINE PRESSURE AGAINST THE DISC, TRANSFERRED THRU THE VALVE'S HOLLOW SHAFT TO THE TOP OF THE DIAPHRAGM, WILL CLOSE THE VALVE. CONTROL PRESSURE AT PORT "D" WILL OPEN THE VALVE. ADDITION OF "SPRING ASSIST CLOSED" FEATURE IS RECOMMENDED FOR THE FOLLOWING CONDITIONS:

1. LOW PRESSURE AND/OR FLOW.
2. VALVE DISCHARGES TO ATMOSPHERE.

NORMALLY CLOSED FEATURE NOT RECOMMENDED FOR LINE MEDIA CONTAINING SOLIDS, HIGH TEMPERATURES OR OTHER MEDIA CONDITIONS WHICH MAY DAMAGE THE DIAPHRAGM.

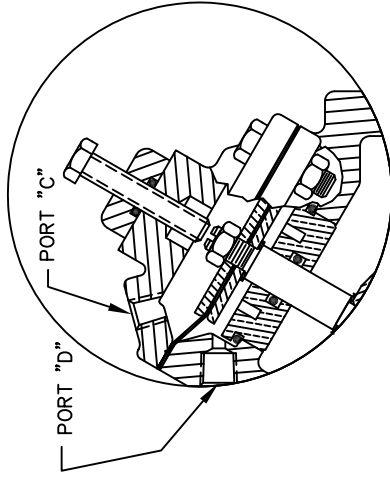

LIMIT STOP

INCLUDES AN ADJUSTMENT SCREW WHICH LIMITS THE VALVE STROKE. MAY BE USED TO CONTROL FLOW RATE. HOWEVER, FLOW RATE WILL VARY WITH CHANGES IN PRESSURE.

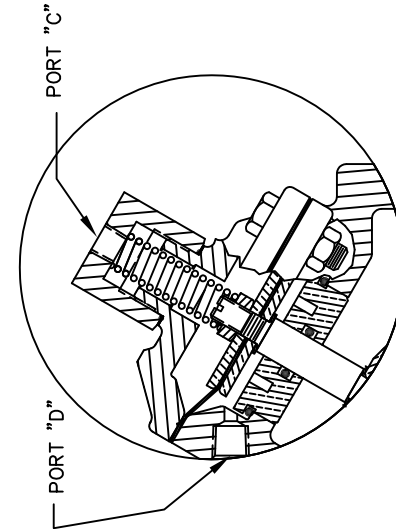

SPRING ASSIST CLOSED

SPRING SERVES AS AN ASSIST TO ASSURE FULL VALVE CLOSURE IN THE ABSENCE OF LINE AND CONTROL PRESSURES.

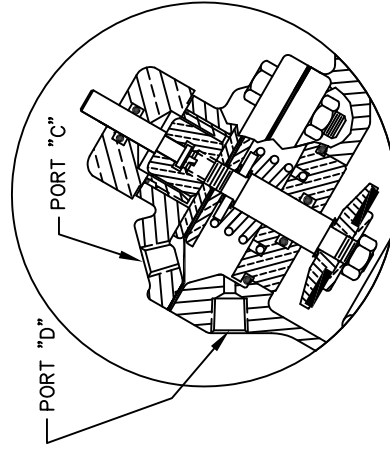

POSITION INDICATOR

INDICATOR ROD IS ATTACHED TO MAIN VALVE STEM TO SHOW POSITION OF VALVE. ONLY AVAILABLE WITH SPRING ASSIST OPEN OPTION.

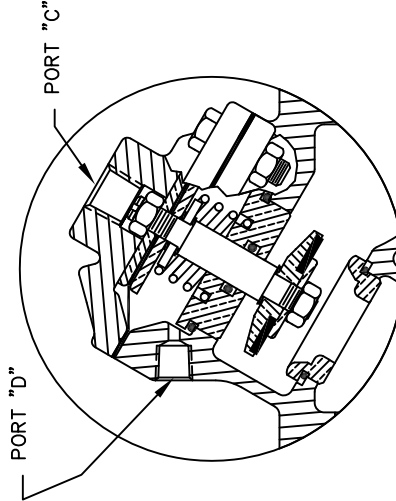

SPRING ASSIST OPEN

SPRING SERVES AS AN ASSIST TO ASSURE FULL VALVE OPENING IN THE ABSENCE OF LINE AND CONTROL PRESSURES.

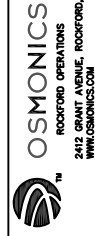

SERIES 420 DIAPHRAGM VALVES

FORM NO. 1078116

B	INITIAL RELEASE	1429	JWB	21JUN01	VKP	SCALE	DRAWN	DATE	DWG. NO.
REV	DESCRIPTION	ECO	DWN	DATE	APVD	N/A	JWB	25APR01	1078117

DIAPHRAGM VALVE INFORMATION - STANDARD MODEL

METAL DIAPHRAGM VALVES (421 THRU 429)

SERIES	PIPE SIZE	SEAT DIAMETER IN. CM.	SEAT AREA SQ. IN. SQ. CM.	DIAPHRAGM AREA SQ. IN. SQ. CM.	TOTAL STROKE IN. CM.	DIAPHRAGM CHAMBER (VOLUME) CUBIC IN. CUBIC CM.	Cv	Kv	FLOW RATE		PRESSURE DROP	
									@ 10 FT./SEC. (3 M./SEC.) NOTE 1 GAL./MIN. CU./HR.	@ 20 FT./SEC. (6 M./SEC.) NOTE 2 GAL./MIN. CU./HR.	@ 10 FT./SEC. (3 M./SEC.) NOTE 1 P.S.I. bar	@ 20 FT./SEC. (6 M./SEC.) NOTE 2 P.S.I. bar
V42B	3/4"	0.97 2.5	0.74 4.8	2.10 13.0	0.47 1.2	2.06 33.8	11.4	9.8	23 5	46 10	4.1 0.3	16.3 1.12
V42C	1"	0.97 2.5	0.74 4.8	2.10 13.0	0.47 1.2	2.06 33.8	12.8	11.0	23 5	46 10	3.2 0.22	13.0 0.9
V42D	1 1/4"	1.34 3.4	1.41 9.1	6.49 41.9	0.61 1.5	5.20 85.2	26.5	23	44 10	88 20	2.8 0.2	11.0 0.7
V42E	1 1/2"	1.34 3.4	1.41 9.1	6.49 41.9	0.61 1.5	5.20 85.2	32.5	28	44 10	88 20	1.8 0.12	7.3 0.5
V42F	2" (425)	2.02 5.1	3.20 20.6	11.04 71.2	0.70 1.8	10.50 172.1	56	48	100 23	200 46	3.2 0.22	12.7 0.87
V42G	2" (426)	2.31 5.9	4.19 27.0	15.03 97.0	0.99 2.5	16.34 267.8	68	59	130 29	260 58	3.7 0.25	14.7 1.01
V42H	2 1/2"	2.31 5.9	4.19 27.0	15.03 97.0	0.99 2.5	16.34 267.8	84	72	130 29	260 58	2.4 0.16	9.7 0.67
V42J	3"	2.96 7.5	6.88 44.4	22.69 146.4	1.05 2.7	32.80 537.6	134	116	214 49	428 98	2.6 0.18	10.2 0.7
V42K	4"	3.84 9.7	11.58 74.7	33.82 218.2	1.92 4.9	78.83 1292.0	275	238	360 83	720 166	1.7 0.12	6.9 0.47
V42L	6"	6.06 15.4	28.84 186.1	120.28 776.0	1.70 4.3	296.52 4860.0	680	588	899 204	1798 408	1.8 0.12	7.0 0.5

* Cv - FLOWRATE (GAL./MIN.) OF WATER AT 60° F. AT 1 P.S.I. PRESSURE DROP

** Kv - FLOWRATE (CU. M./HR) OF WATER AT 15.5° C. AT 1 BAR PRESSURE DROP

NOTE 1: MAXIMUM CONTINUOUS VELOCITY THROUGH THE VALVE.

NOTE 2: MAXIMUM CONTINUOUS VELOCITY. EXTENDED SERVICE AT THIS VELOCITY MAY CAUSE CAVITATION.

THE DATA PRESENTED HERE IS BELIEVED TO BE RELIABLE AND OFFERED AS SUGGESTION ONLY. ACTUAL RESULTS MAY VARY DEPENDING UPON APPLICATION.

TO DETERMINE FLOWRATE AT ANY GIVEN PRESSURE DROP, THE FOLLOWING FORMULAS CAN BE USED.

FOR WATER AND LIQUIDS:

$$Q = \frac{Cv \sqrt{\Delta P}}{\sqrt{e}}$$

FOR AIR AND GAS:

$$Cv = \frac{CFM \sqrt{e}}{.5P1} \quad \text{WHEN } P2 \leq .5P1$$

$$Cv = \frac{CFM \sqrt{e}}{\sqrt{\Delta P} P2} \quad \text{WHEN } P2 > .5P1$$

CFM - CU. FT./MIN. FLOW

Q - FLOWRATE IN GAL./MIN.

ΔP - PRESSURE DROP (LB./SQ. IN.)

e - SPECIFIC GRAVITY (WATER = 1.00)

e - SPECIFIC GRAVITY (AIR = 1.00)

P1 - INLET PRESSURE (LB./SQ. IN.)

P2 - OUTLET PRESSURE (LB./SQ. IN.)

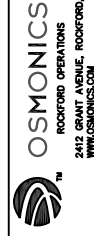

FORM NO. 1078116

SERIES 420 DIAPHRAGM VALVES

REV	DESCRIPTION	ECO	DMN	DATE	APVD	SCALE	DRAWN	DATE	DWG. NO.
B	INITIAL RELEASE	1429	JWB	21JUN01	VKP	N/A	JWB	25APR01	1078117

1-1/4" & 1-1/2" DIAPHRAGM VALVE - STANDARD MODEL

NO.	DESCRIPTION	STD	PART NO.	QTY.
1	CAST IRON	1-1/4" NPT	1074196 (424-A5)	1
	BODY	1-1/2" NPT	1074199 (424-A6)	
2	CAST BRASS	1-1/4" NPT	1074190 (424-A85)	1
	SEAT - BRASS (REQ'S ASSY. TOOL)	1-1/2" NPT	1074193 (424-A86)	
3	HEX NUT (1/4-28)		1074245 (424-AM)	1
4	DISC PLATE - BRASS		1263852	1
5	O-RING	BUNA N	1071678 (ORB-028)	1
		E.P.D.M.	1071723 (ORE-028)	
6	DISC	VITON	1071793 (ORV-028)	1
		BUNA	1074232 (424-J)	
7	DISC HOLDER - BRASS	E.P.D.M.	1074233 (424-E)	1
		FKM	1074236 (424-W)	
8	GASKET - COPPER	HYPAR	1074234 (424-H)	1
9	O-RING	BUNA N	1073948 (200-G6)	1
		E.P.D.M.	1071695 (ORB-132)	
10	SHAFT GUIDE - BRASS (REQ'S ASSY TOOL)	FKM	1071734 (ORE-132)	1
		FKM	1071806 (ORV-132)	
11	DIAPHRAGM PLATE - BRASS		1074225 (424-G60)	1
12	HEX NUT (5/16-24)		1074220 (424-D)	2
13	CAP	CAST IRON	1263853	1
		CAST BRASS	1074202 (424-C)	
14	HEX SCREW	PLATED STEEL	1074206 (424-CB)	4
		STN. STL.	1072399 (S2Z-0007)	
15	DIAPHRAGM	BUNA N	1072392 (S2S-0156)	1
		FKM	1074222 (424-FB)	
16	GASKET - COPPER	BUNA N	1074224 (424-FV)	1
		PLATED STEEL	1074252 (424-R)	
17	HEX NUT	STN. STL.	1071656 (N1Z-0008)	4
		BUNA N	1071649 (NUS-0007)	
18	O-RING	E.P.D.M.	1071689 (ORB-101C)	1
		FKM	1071726 (ORE-101C)	
19	SHAFT (NORMALLY OPEN)		1239021 (ORW-101C)	1

FORM NO. 1077614

G	CHANGED SHAFT NUTS & UPDATED O-RING P/N'S	1635	MSM	01Nov05	
	DESCRIPTION	1672	ECO	DMN	DATE
REV					APVD
 GE Osmonics ROCKFORD OPERATIONS 2412 GRANT AVENUE ROCKFORD, IL 61103-3891 (815) 964-9421 WWW.GEWATER.COM					
SERIES 424 DIAPHRAGM VALVE 1 1/4" & 1 1/2" N.P.T. OR B.S.P.T.					
DRAWN	JWB	DATE	25Apr01	DRAWING NO.	1084019

REPAIR PARTS KITS

DESCRIPTION	PART NO.
DIAPHRAGM & SEALS KIT CONSISTS OF ITEM NO'S 3,5,6,8,9,12,15,16,18	1070069 (424-RA) 1070082 (424-RAE) 1070094 (424-RAV) FKM
INT. PARTS KIT (NORM. OPEN) CONSISTS OF STANDARD ITEM NO'S 4,7,10,11(2),19 SEAT (ITEM NO. 2)	1070119 (424-RF) 1074245 (424-MO)

ASSEMBLY TOOLS

DESCRIPTION	PART NO.
FOR INSTALLATION & REMOVAL OF SEAT (ITEM #2) (TOOL NOT SHOWN)	1074247 (424-MT)
FOR INSTALLATION & REMOVAL OF SHAFT GUIDE (ITEM #10) (TOOL NOT SHOWN)	1074227 (424-GT)

NOTE:

- AMERICAN NATIONAL STANDARD TAPER PIPE THREADS (NPT) PER ANSI B2.1-1968
- VALVES AVAILABLE WITH B.S.P.T. END CONNECTIONS.

SEE REVERSE SIDE FOR CONFIGURATION OPTIONS

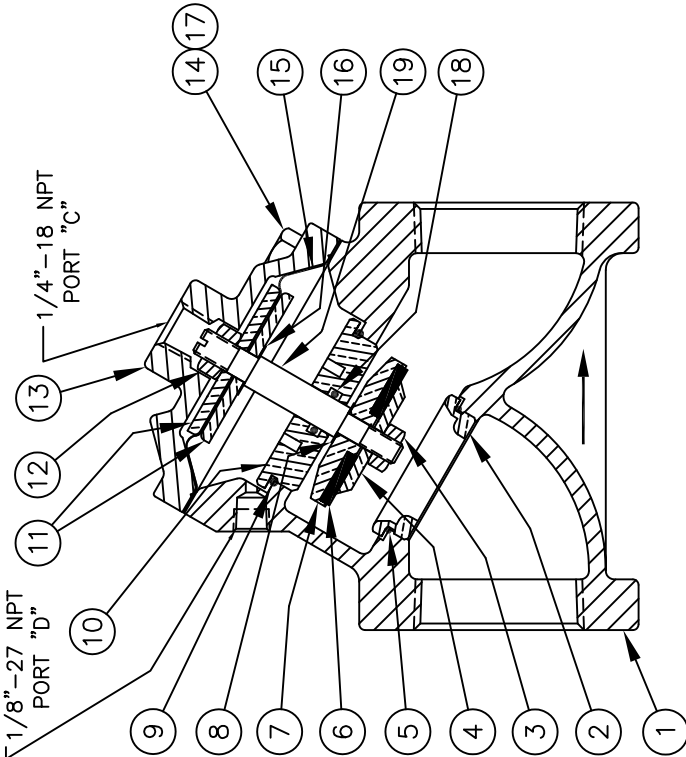
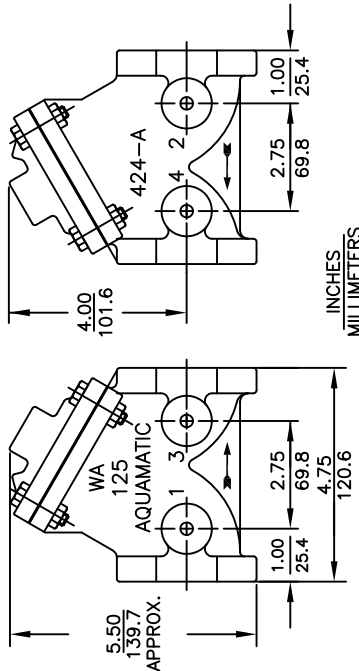

1070023 (V42D-0000-00000) (1-1/4" NPT)
 1070025 (V42E-0000-00000) (1-1/2" NPT)
NORMALLY OPEN (STANDARD)

1-1/4" & 1-1/2" DIAPHRAGM VALVE - OPTIONAL MODELS

NO.	DESCRIPTION	STD	PART NO.	QTY.
LIMIT STOP MODEL				
20	SCREW	*	1072362 (SCS-0031)	1
21	O-RING	*	1071668 (ORB-012)	1
22	NUT	*	1077534 (400-H)	1
23	CAP	*	1074210 (424-CCC)	1
			1074213 (424-COCB)	
NORMALLY CLOSED MODEL				
24	PIPE PLUG (1/4" N.P.T.)	*	1071918 (PLZ-0008)	1
			1071904 (PLB-0009)	
25	SHAFT (NORMALLY CLOSED)	*	1074241 (424-L)	1
SPRING ASSIST CLOSED MODEL				
26	CENTERING NUT	*	1074276 (424-X)	1
27	RETAINER NUT - BRASS	*	1074274 (424-T)	1
28	PIPE PLUG (1/8" N.P.T.)	*	1071917 (PLZ-0005)	1
			1071903 (PLB-0007)	
29	SPRING	*	1074270 (424-SS)	1
30	O-RING	*	1071674 (ORB-020)	1
31	CAP	*	1074208 (424-CC)	1
			1074209 (424-COB)	
SPRING ASSIST OPEN MODEL				
16	GASKET - COPPER	*	1074252 (424-R)	1
32	SPRING	*	1236766	1
33	CENTERING WASHER - BRASS	*	1074382 (426-HA)	1
POSITION INDICATOR MODEL				
34	CAP	*	1074217 (424-CF)	1
			1074218 (424-CFB)	
35	O-RING	*	1071692 (ORB-116)	1
36	SHAFT GUIDE BUSHING	*	1074121 (421-GF)	1
37	INDICATOR SHAFT	*	1074251 (424-PM)	1
38	O-RING	*	1071688 (ORB-108TC)	1
39	TOP NUT	*	1074272 (424-TB)	1
40	LOCKWASHER	*	1073590 (WAS-0007)	1

FORM NO. 1077614

G	CHANGED SHAFT NUTS & UPDATED O-RING P/N'S	1635	MSM	01Nov05		
	REV	DESCRIPTION	ECO	DWN	DATE	APVD
 <p>ROCKFORD OPERATIONS 2412 GRANT AVENUE ROCKFORD, IL 61103-3891 (815) 964-9421 WWW.GEWATER.COM</p>						
SERIES 424 DIAPHRAGM VALVE						
1 1/4" & 1 1/2" N.P.T. OR B.S.P.T.						
DRAWN	JWB	DATE	25Apr01	DRAWING NO.	1084019	

(1/8" NPT)
(USED WITH NORMALLY CLOSED VALVES ONLY)

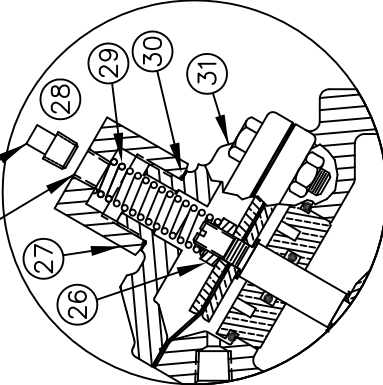

1072716 (V42D-0002-00000) (1-1/4" NPT)
1072792 (V42E-0002-00000) (1-1/2" NPT)

SPRING ASSIST CLOSED

NOTE:

1. SPRING ASSIST CLOSED MODEL CANNOT BE COMBINED WITH LIMIT STOP MODEL.
2. VALVES AVAILABLE WITH B.S.P.T. END CONNECTIONS.

SEE REVERSE SIDE FOR STANDARD NORMALLY OPEN MODEL

(1/4" NPT)

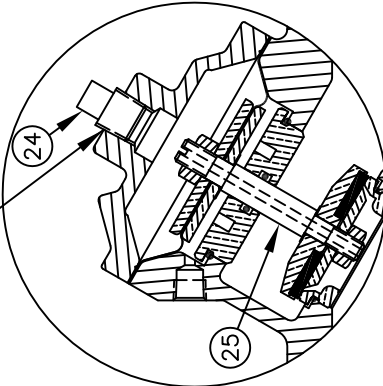

1072723 (V42D-0030-00000) (1-1/4" NPT)
1070026 (V42E-0030-00000) (1-1/2" NPT)

NORMALLY CLOSED

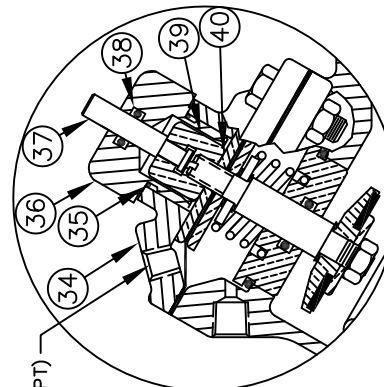

1072722 (V42D-0021-00000) (1-1/4" NPT)
1072804 (V42E-0021-00000) (1-1/2" NPT)

POSITION INDICATOR

(USED WITH NORMALLY CLOSED VALVES ONLY)
(1/8" NPT)

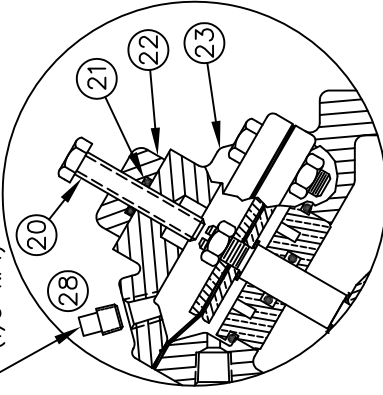

1072720 (V42D-0010-00000) (1-1/4" NPT)
1070028 (V42E-0010-00000) (1-1/2" NPT)

LIMIT STOP

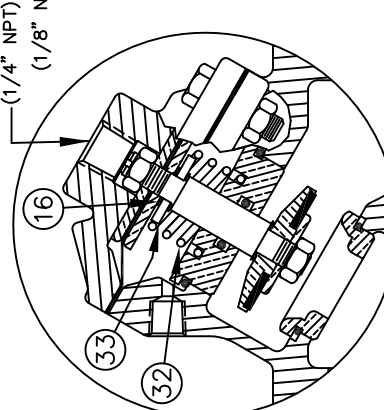

1072715 (V42D-0001-00000) (1-1/4" NPT)
1070027 (V42E-0001-00000) (1-1/2" NPT)

SPRING ASSIST OPEN

DESCRIPTION	PART NO.	DESCRIPTION	PART NO.
CONVERSION KITS		REPAIR PARTS KITS	
CONVERSION KIT (LIMIT STOP) CONSISTS OF STANDARD ITEM NO'S 20,21,22,23	1074243 (424-LSC)	INT. PARTS KIT (LIMIT STOP) CONSISTS OF STANDARD ITEM NO'S 20,21,22	1074242 (424-LS)
CONVERSION KIT (SPRING ASSIST CLOSED) CONSISTS OF STANDARD ITEM NO'S 26 THRU 31	1074266 (424-SOC)	INT. PARTS KIT (NORM. CLOSED) CONSISTS OF STANDARD ITEM NO'S 4,7,10,11(2),25	1070130 (424-RC)
CONVERSION KIT (SPRING ASSIST OPEN) CONSISTS OF STANDARD ITEM NO'S 10,16,32,33	1074269 (424-SOC)	INT. PARTS KIT (SPRING ASSIST CLOSED) CONSISTS OF STANDARD ITEM NO'S 26,29,30	1074265 (424-SC)
CONVERSION KIT (POSITION INDICATOR) CONSISTS OF STANDARD ITEM NO'S 34 THRU 40	1074250 (424-PIC)	INT. PARTS KIT (SPRING ASSIST OPEN) CONSISTS OF STANDARD ITEM NO'S 16,32,33	1074268 (424-SO)
		INT. PARTS KIT (POSITION INDICATOR) CONSISTS OF STD ITEM NO'S 35 THRU 40	1074249 (424-PI)

3" DIAPHRAGM VALVE - STANDARD MODEL

NO.	DESCRIPTION	STD	PART NO.	QTY.
1	BODY	THREADED	* 1074446 (427-AS)	1
	CAST IRON	FLANGED	* 1074438 (427-AF)	
2	SEAT	THREADED	* 1074449 (427-ASB)	1
	CAST BRASS	BRASS	* 1074505 (427-MO)	
3	HEX NUT (5/16-24)	STN. STL.	* 1074507 (427-MO)	2
			* 1263853	
4	DISC PLATE	BRASS	* 1074493 (427-K)	1
		STN. STL.	* 1074495 (427-KS)	
5	O-RING	BUNA N	* 1071706 (ORB-233)	1
		E.P.D.M.	* 1071754 (ORE-233)	
		FKM	* 1071828 (ORV-233)	
6	DISC	BUNA	* 1074487 (427-J)	1
		E.P.D.M.	* 1074489 (427-JE)	
		FKM	* 1074492 (427-JV)	
		HYCAR	* 1074490 (427-JH)	
7	DISC HOLDER	BRASS	* 1074485 (427-HO)	1
		STN. STL.	* 1074486 (427-HSS)	
8	GASKET	COPPER	* 1074252 (424-R)	2
		BUNA N	* 1071708 (ORB-237)	
9	O-RING	E.P.D.M.	* 1071755 (ORE-237)	1
		FKM	* 1071828 (ORV-237)	
10	SHAFT GUIDE (REQ'S ASSY TOOL)	BRASS	* 1074481 (427-GO)	1
		STN. STL.	* 1074479 (427-GSO)	
11	DIAPHRAGM PLATE	BRASS	* 1074471 (427-D)	2
		STN. STL.	* 1074472 (427-DA)	
12	CAP	CAST IRON	* 1074454 (427-C)	1
		CAST BRASS	* 1074457 (427-CB)	
13	HEX SCREW	PLATED STEEL	* 1072405 (SCZ-0025)	6
		STN. STL.	* 1072390 (SCS-0192)	
14	DIAPHRAGM	BUNA N	* 1074475 (427-FB)	1
		FKM	* 1074477 (427-FV)	
15	HEX NUT	PLATED STEEL	* 1071658 (NIZ-0014)	6
		STN. STL.	* 1071652 (NUS-0014)	
16	O-RING	BUNA N	* 1071691 (ORB-1141C)	1
		E.P.D.M.	* 1071729 (ORE-1141C)	
		FKM	* 1242391 (ORV-1141C)	
17	SHAFT (NORMALLY OPEN)		* 1074496 (427-L)	1
18	DISC SPACER	BRASS	* 1074382 (426-HA)	1
		STN. STL.	* 1074384 (426-HAS)	
19	HEX SCREW	STN. STL.	* 1072359 (SCS-0020)	2

REPAIR PARTS KITS	
DESCRIPTION	PART NO.
DIAPHRAGM & SEALS KIT CONSISTS OF ITEM NO'S 3(2), 5, 6, 8(2), 9, 14, 16	1070072 (427-RA) 1070085 (427-RAE) 1070087 (427-RM)
	BUNA N INCLUDES DIAPHRAGM DIAPHRAGM DIAPHRAGM
	E.P.D.M. INCLUDES DIAPHRAGM DIAPHRAGM
	FKM INCLUDES DIAPHRAGM DIAPHRAGM
INT. PARTS KIT (NORM. OPEN) CONSISTS OF STANDARD ITEM NO'S 4, 7, 10, 11(2), 17, 18	1070122 (427-RF)
SEAT (ITEM NO. 2)	1074505 (427-MO)

ASSEMBLY TOOLS	
DESCRIPTION	PART NO.
FOR INSTALLATION & REMOVAL OF SHAFT GUIDE (ITEM #10) (NOT SHOWN)	1-1/4" HEX SOCKET

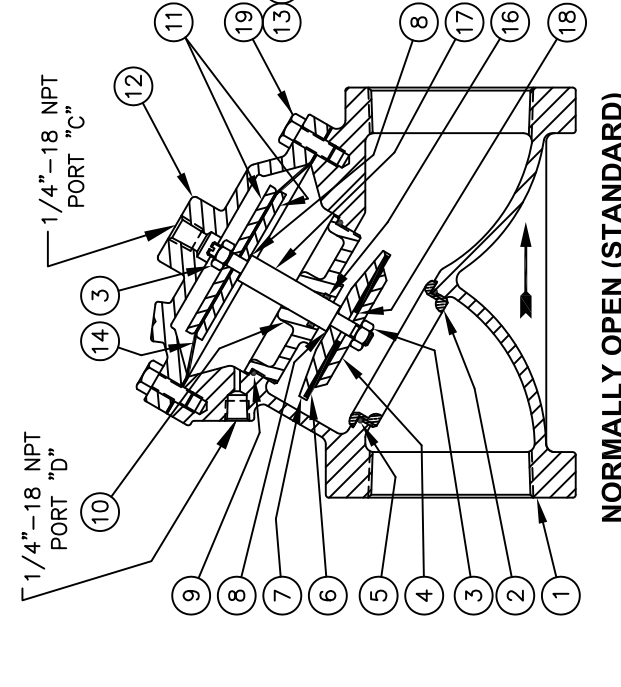
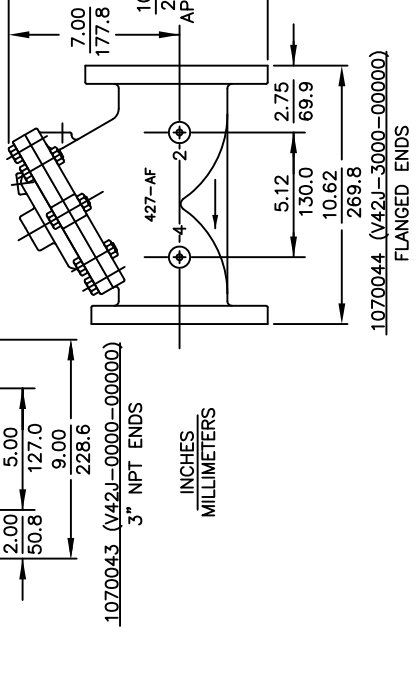
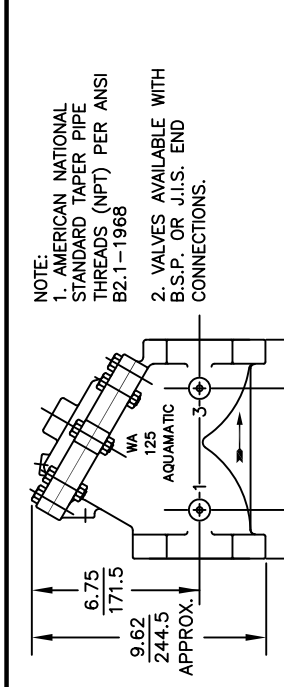

SEE REVERSE SIDE FOR CONFIGURATION OPTIONS

FORM NO. 1077617

H	CHANGED SHAFT NUTS & UPDATED O-RING P/N'S	1635	MSM	01Nov05
REV	DESCRIPTION	ECO	DWN	DATE
				APVD

ROCKFORD OPERATIONS
2412 GRANT AVENUE
ROCKFORD, IL 61103-3991
(815) 964-9421 WWW.GEWATER.COM

GE Osmonics

SERIES 427 DIAPHRAGM VALVE

3" PIPE SIZE

DRAWN	JWB	DATE	02May01	DRAWING NO.	1084022
-------	-----	------	---------	-------------	---------

3" DIAPHRAGM VALVE - OPTIONAL MODELS

NO.	DESCRIPTION	STD	PART NO.	QTY.
LIMIT STOP MODEL				
20	SCREW	*	1072365 (SCS-0043)	1
21	O-RING	*	1071690 (ORB-112)	1
22	NUT	*	1074434 (426-U)	1
			CAST IRON	
23	CAP	*	1074462 (427-CCC)	1
			CAST BRASS	
23	CAP	*	1074465 (427-CCCB)	1
NORMALLY CLOSED MODEL				
			PLATED STEEL	
24	PIPE PLUG (1/4" N.P.T.)	*	1071918 (PLZ-0008)	1
			BRASS	
24	PIPE PLUG (1/4" N.P.T.)	*	1071904 (PLB-0009)	1
			STN. STL.	
25	SHAFT (NORMALLY CLOSED)	*	1071915 (PLS-0001)	1
			1074499 (427-L)	1
SPRING ASSIST CLOSED MODEL				
			BRASS	
26	CENTERING WASHER	*	1074083 (421-AH)	1
			STN. STL.	
26	CENTERING WASHER	*	1074084 (421-AHS)	1
			BRASS	
27	RETAINER NUT	*	1074430 (426-TI)	1
			STN. STL.	
27	RETAINER NUT	*	1078686	1
			PLATED STEEL	
28	PIPE PLUG (1/8" N.P.T.)	*	1071917 (PLZ-0005)	1
			BRASS	
28	PIPE PLUG (1/8" N.P.T.)	*	1071903 (PLB-0007)	1
			STN. STL.	
29	SPRING	*	1071916 (PLS-0002)	1
			1074428 (426-SS)	1
30	O-RING	*	1071677 (ORB-025)	1
			CAST IRON	
30	O-RING	*	1074460 (427-CC)	1
			CAST BRASS	
31	CAP	*	1074461 (427-CCB)	1
SPRING ASSIST OPEN MODEL				
			COPPER	
8	GASKET	*	1074252 (424-R)	1
			LEAD	
8	GASKET	*	1074263 (424-RL)	1
			BRASS	
32	SPRING	*	1074423 (426-S)	1
			STN. STL.	
33	CENTERING WASHER	*	1074436 (426-V)	1
			STN. STL.	
POSITION INDICATOR MODEL				
			CAST IRON	
34	CAP	*	1074468 (427-CF)	1
			CAST BRASS	
35	O-RING	*	1074469 (427-CFB)	1
			1071692 (ORB-116)	1
36	SHAFT GUIDE BUSHING	*	1074121 (421-GF)	1
			1074510 (427-PN)	1
37	INDICATOR SHAFT	*	1071688 (ORB-1081C)	1
			1074332 (425-TB)	1
38	O-RING	*	1071688 (ORB-1081C)	1
			1074332 (425-TB)	1
39	TOP NUT	*	1073590 (WAS-0007)	1
40	LOCKWASHER	*	1073590 (WAS-0007)	1

FORM NO. 1077617

H	CHANGED SHAFT NUTS & UPDATED O-RING P/N'S	1635	MSM	10/10/05	
REV	DESCRIPTION	ECO	DWN	DATE	APVD

ROCKFORD OPERATIONS
2412 GRANT AVENUE
ROCKFORD, IL 61103-3991
(815) 964-9421 WWW.GEWATER.COM

GE Osmonics

SERIES 427 DIAPHRAGM VALVE
3" PIPE SIZE

DRAWN	JWB	DATE	02May01	DRAWING NO.	1084022
-------	-----	------	---------	-------------	---------

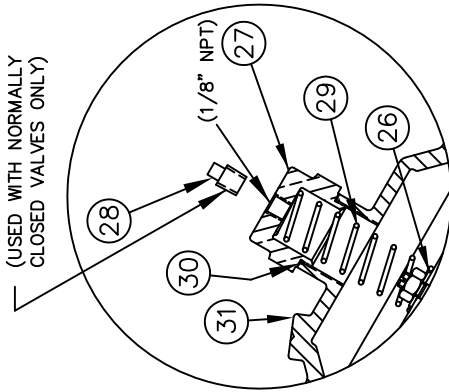

1073047 (V42J-0002-00000) (THREADED)
1073100 (V42J-3002-00000) (FLANGED)

SPRING ASSIST CLOSED

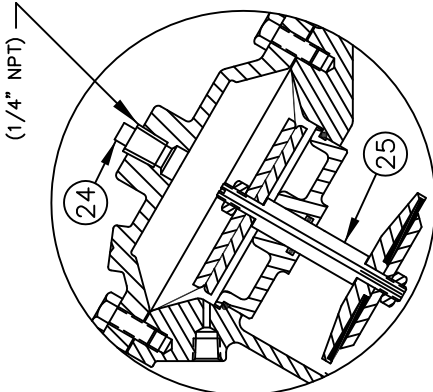

1073055 (V42J-0030-00000) (THREADED)
1073113 (V42J-3030-00000) (FLANGED)

NORMALLY CLOSED

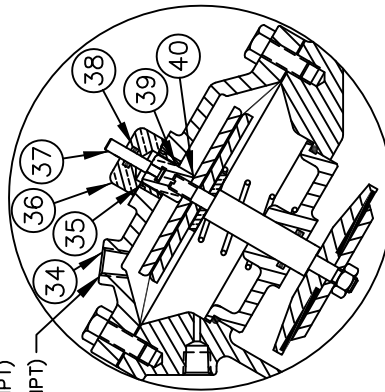

1073054 (V42J-0021-00000) (THREADED)
1077374 (V42J-3021-00000) (FLANGED)

POSITION INDICATOR

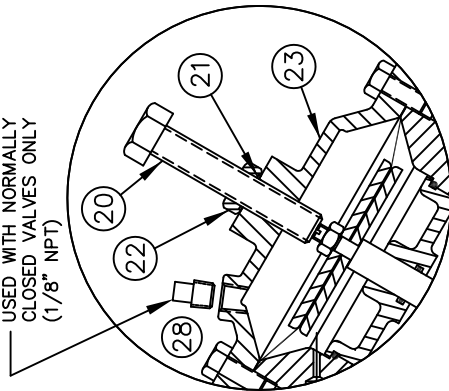

1073045 (V42J-0010-00000) (THREADED)
1073097 (V42J-3010-00000) (FLANGED)

LIMIT STOP

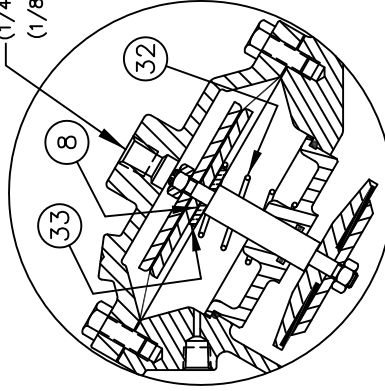

1073045 (V42J-0001-00000) (THREADED)
1073097 (V42J-3001-00000) (FLANGED)

SPRING ASSIST OPEN

CONVERSION KITS		REPAIR PARTS KITS	
DESCRIPTION	PART NO.	DESCRIPTION	PART NO.
CONVERSION KIT (LIMIT STOP)	1074502 (427-LSC)	INT. PARTS KIT (LIMIT STOP)	1074501 (427-LS)
CONSISTS OF STANDARD ITEM NO'S 20,21,22,23		CONSISTS OF STANDARD ITEM NO'S 20,21,22	
CONVERSION KIT (SPRING ASSIST CLOSED)	1074519 (427-SCC)	INT. PARTS KIT (NORM. CLOSED)	1070133 (427-RG)
CONSISTS OF STANDARD ITEM NO'S 26 THRU 31		CONSISTS OF STANDARD ITEM NO'S 4,7,10,11(2),18,25	
CONVERSION KIT (SPRING ASSIST OPEN)	1074521 (427-SO)	INT. PARTS KIT (SPRING ASSIST CLOSED)	1081565 (427-SC)
CONSISTS OF STANDARD ITEM NO'S 8,32,33		CONSISTS OF STANDARD ITEM NO'S 26,29,30	
CONVERSION KIT (POSITION INDICATOR)	1074509 (427-PIC)	INT. PARTS KIT (SPRING ASSIST OPEN)	1074521 (427-SO)
CONSISTS OF STANDARD ITEM NO'S 34 THRU 40		CONSISTS OF STANDARD ITEM NO'S 8,32,33	
		INT. PARTS KIT (POSITION INDICATOR)	1074508 (427-PI)
		CONSISTS OF STD. ITEM NO'S 35 THRU 40	



MFS MID 20-72 SINGLE FILTER MX-II

NOTES

NOTES



2227 South Street
P.O. Box 044170
Racine, WI 53404-7003
Ph. (262) 681-1300
Fax (262) 681-1318
www.Marlo-Inc.com