



**INSTALLATION, OPERATION,
AND MAINTENANCE MANUAL**

MR 150M–1050M

TWIN ALTERNATING – SYSTEM 7

MX III CONTROLLER

COMMERCIAL WATER CONDITIONERS

COMPLETE FOR FUTURE REFERENCE:

MODEL NO:

SERIAL NO:

DATE INSTALLED:

DEALER:

Marlo Incorporated
2227 South Street
P.O. Box 044170
Racine, WI 53404-7003
www.Marlo-Inc.com



MR 150M–1050M TWIN ALTERNATING – MX III CONTROLLER

IMPORTANT PLEASE READ:

- Warranty of this product extends to manufacturing defects.
- The information, specifications and illustrations in this manual are based on the latest information available at the time of printing. The manufacturer reserves the right to make changes at any time without notice.
- This product should be installed by a plumbing professional on potable water systems only.
- This product must be installed in compliance with all local and state and municipal plumbing and electrical codes. Permits may be required at the time of installation.
- If operating pressure exceeds 100 psi a pressure reducing valve must be installed. If operating pressure drops below 30 psi a booster pump must be installed.
- Do not install the unit where temperatures may drop below 32°F or rise above 100°F.
- A prefilter should be used on installations in which free solids are present.
- A constant voltage of 120V/60Hz (unless otherwise specified) must be supplied to the controller to maintain proper function.
- Union or flange fittings are recommended at the control valve's inlet, outlet, and drain connections
- If distance of drain line is over a 10 ft. vertical or 25 ft. horizontal run, increase drain line one pipe size over that provided on the control valve.
- Do not make a direct connection to the drain. Provide an air gap of at least four times the diameter of the pipe to conform to sanitation codes and to permit observation of the flow.

PLEASE CIRCLE AND/OR FILL IN THE APPROPRIATE DATA FOR FUTURE REFERENCE:

Softener Model: MR _____

System Size: Single/Twin/Triple/Quad

Meter Size: _____

Configuration: Timeclock/Twin Alt/Parallel/Progressive

Unit Capacity: _____ Grains

Feed Water Hardness: _____ Grains

Treated Water: _____ Gallons/Liters

BW/Regen Time _____ AM/PM or OFF

Additional Notes: _____

TABLE OF CONTENTS**SYSTEM INFORMATION**

Product Warranty.....	1
General Arrangement Drawings	2
Dimension Width	3
Specification Table	4
Wiring Diagram.....	5
Tubing Diagram	6

INSTALLATION

General Installation.....	7
Piping Installation	7
Resin & Gravel Loading	8
Brine Tank Installation	9

OPERATION

Start-Up Instructions	10
Volume Remaining/Batch Calculation	11
General Softener Operation	12
Flow Diagrams.....	13
Brine Maker Operation	14
Features of the NXT Controller.....	15
User Mode Programming Flow Chart.....	16
Network Communication Cables and Connections	17
Controller Operation	18
Controller Display Screen Features.....	19
Controller Display Screen Examples	20
Programming Parameters	22
Master Mode Programming Flow Chart.....	23
Diagnostic Mode Programming Flow Chart.....	33

MAINTENANCE

MX III Replacement Parts.....	36
Replacement Valves	37
Aquamatic Valve Repair Kits	38
2536 Flow Sensor.....	39
Brine Tank Assemblies	40
Error Codes	42
Troubleshooting.....	43



MR 150M–1050M TWIN ALTERNATING – MX III CONTROLLER

COMMERCIAL AND INDUSTRIAL PRODUCT WARRANTY

Marlo, Inc. warrants all commercial and industrial water treatment products manufactured and/or distributed by it to be free from defects in materials and workmanship for a period of one (1) year from the date of shipment. If within that period any products shall be proven to Marlo, Inc.'s satisfaction to be defective, those products will be replaced or the price refunded at Marlo Inc.'s option.

Marlo Inc.'s obligations or nonperformance, defective, or any damage caused by its products or their use, and buyer's exclusive remedy therefore, shall be limited to product replacement or refund and shall be conditioned upon Marlo Inc.'s receiving written notice together with a demand for such replacement or refund:

The foregoing warranty is exclusive and in lieu of all other expressed implied warranty (except of title) including but not limited to implied warranty of merchantability and fitness for particular purpose.

Marlo Inc. will not be subject to and disclaims the following:

1. Any other obligations or liabilities arising out of breach of contract or out of warranty.
2. Any obligations whatsoever arising from tort claims (including negligence and strict liability or arising under other theories of law with respect to products sold or services rendered by Marlo Inc. or any undertakings, acts, or omissions relating thereto.
3. All consequential, incidental, and contingent damages.

Labor charges, charge backs or handling charges are excluded from Marlo Inc.'s warranty provisions.

COMMERCIAL AND INDUSTRIAL WATER SOFTENER GUARANTEE

Under normal operating conditions:

1. The softener effluent shall be zero soft as determined by a soap test.
2. The loss of softening resin through attrition during the first three (3) years shall not exceed 3% per year.
3. The softening resin shall not be washed out of the system during backwash.
4. The color and turbidity of the softener effluent shall not be greater than the incoming water.
Any mechanical equipment proving defective in workmanship or material within one year after installation or eighteen (18) months after shipment, whichever comes first, shall be replaced FOB factory.

DIMENSION CHART

MODEL	PIPE SIZE			DIMENSION TABLE		
	INLET/OUTLET	DRAIN	INJECTOR	HEIGHT	WIDTH	LENGTH
MR-150-1	1	1	2.0-050	6'-0"	2'-5"	7'-4"
MR-150-1-1/4	1-1/4	1			2'-6"	
MR-150-1-1/2	1-1/2	1			2'-6"	
MR-150-2	2	1			2'-10"	
MR-210-1-1/4	1-1/4	1	3.5-075	6'-1"	2'-8"	8'-0"
MR-210-1-1/2	1-1/2	1			2'-8"	
MR-210-2	2	1			3'-0"	
MR-210-2-1/2	2-1/2	1			3'-1"	
MR-300-1-1/2	1-1/2	1	5.0-075	6'-4"	3'-2"	9'-0"
MR-300-2	2	1			3'-6"	
MR-300-2-1/2	2-1/2	1			3'-7"	
MR-300-3	3	1			3'-8"	
MR-450-1-1/2	1-1/2	1	5.0-075	6'-10"	3'-2"	9'-6"
MR-450-2	2	1			3'-6"	
MR-450-2-1/2	2-1/2	1			3'-7"	
MR-450-3	3	1			3'-8"	
MR-600-1-1/2	1-1/2	1-1/2	7.0-100	7'-5"	3'-8"	11'-3"
MR-600-2	2	1-1/2			4'-0"	
MR-600-2-1/2	2-1/2	1-1/2			4'-1"	
MR-600-3	3	1-1/2			4'-2"	
MR-750-2	2	1-1/2	7.0-100	8'-5"	4'-0"	11'-3"
MR-750-2-1/2	2-1/2	1-1/2			4'-1"	
MR-750-3	3	1-1/2			4'-2"	
MR-900-2	2	2	10.0-100	7'-10"	4'-6"	12'-6"
MR-900-2-1/2	2-1/2	2			4'-7"	
MR-900-3	3	2			4'-8"	
MR-1050-2	2	2	10.0-100	8'-10"	4'-6"	13'-2"
MR-1050-2-1/2	2-1/2	2			4'-7"	
MR-1050-3	3	2			4'-8"	

SPECIFICATION CHART

SYSTEM SIZE	MODEL	150			210			300			450			600			750			900			1050			
		1	1½	2	1½	2	2½	1½	2	2½	3	1½	2	2½	3	1½	2	2½	3	2	2½	3	2	2½	3	
SYSTEM SIZE	VALVE SIZE (IN)																									
	MAX CAPACITY (KILOGRAMS)	150																								
FLOWRATE (GPM)	MIN CAPACITY (KILOGRAMS)	100																								
	SERVICE - CONTINUOUS (GPM)	32	42	45	57	41	64	80	115	68	92	140	165	140	140	175	90	140	160	105	150	188	95	135	173	
	SERVICE - PEAK (GPM)	55	78	69	97	57	86	110	160	92	125	190	230	90	115	170	190	116	190	230	133	218	279	124	210	259
	BACKWASH & FAST FLUSH (GPM)	10																								
TIMER SETTINGS	BRINE DRAW & RINSE (GPM)	2.5																								
	BACKWASH & FAST FLUSH (MIN)	10																								
SOFTENER TANK	BRINE DRAW & RINSE (MIN)	60																								
	FAST FLUSH (MIN)	6																								
EQUIPMENT	SIZE (IN)	20x54																								
	GRAVEL (LBS)	100																								
BRINE SYSTEMS	RESIN (FT ³)	5																								
	FREEBOARD (IN)	24																								
SALT	TANK SIZE	24x50																								
	MAX SALT STORAGE (LBS)	700																								
SALT	INJECTOR CODE	2.0-050																								
	INJECTOR COLOR	RED																								
SALT	SALT DOSAGE- MAX (LBS)	75																								
	SALT DOSAGE- MIN (LBS)	30																								
SALT	BRINE VALVE FLOAT HEIGHT - MAX	12																								
	BRINE VALVE FLOAT HEIGHT - MIN	3																								

WIRING DIAGRAM 48ES STAGER CONTROLLER

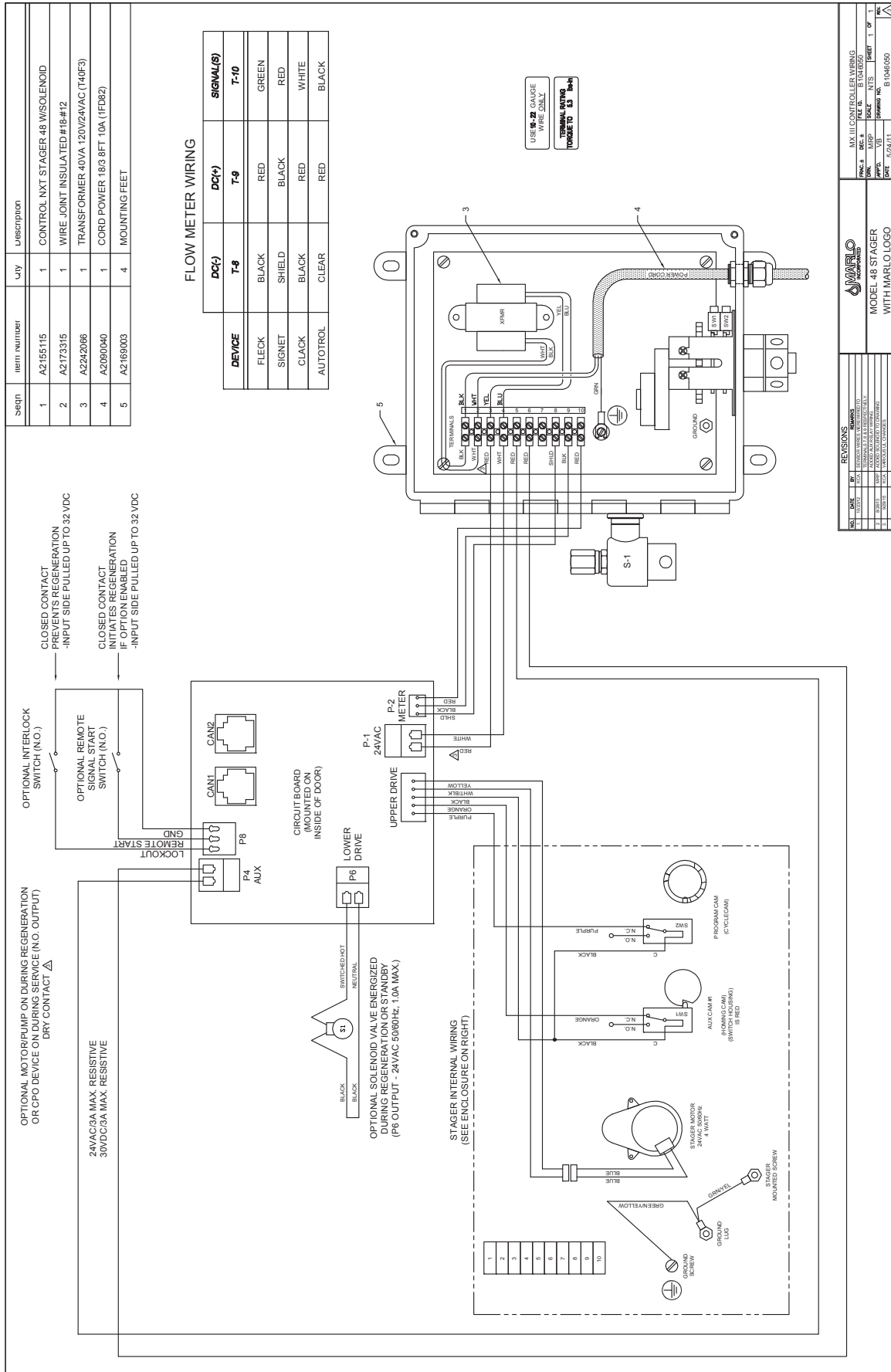

REVISIONS		MX III CONTROLLER WIRING	
REV	DATE	BY	DESCRIPTION
1	01/14/20	MSR	INITIAL RELEASE
2	01/14/20	MSR	SCALE NTS
3	01/14/20	MSR	SCALE NTS
4	01/14/20	MSR	SCALE NTS
5	01/14/20	MSR	SCALE NTS
6	01/14/20	MSR	SCALE NTS

SCALE	NTS	SHEET	1 OF 1
DATE	01/14/20	DRAWING NO.	B1046350

MARLO INCORPORATED	
MODEL 48 STAGER	
WITH MARLO LOGO	

TUBING DIAGRAM - VALVE NEST - MULTITANK

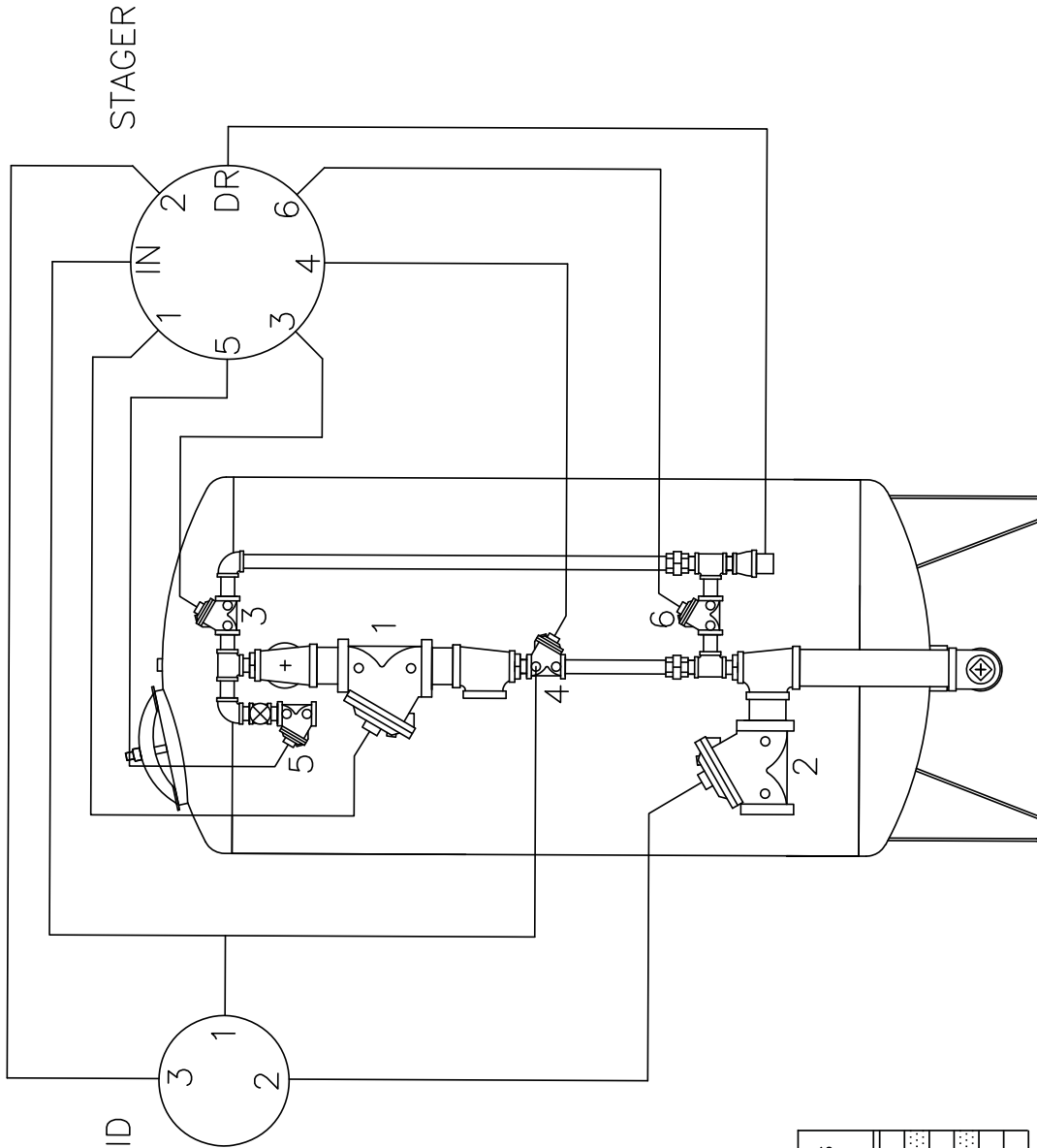

PARKER SOLENOID VALVE

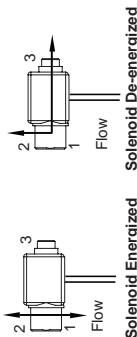

Energized To Close
The NXT Stager control can operate an optional 24 VAC solenoid to control when a tank is off line. This solenoid is electrically connected to the "lower drive" connection on the circuit board, and control pressure is run through the solenoid to the service outlet diaphragm valve.

The solenoid installed at the factory is a universal type. It is plumbed in an energize to close configuration.

When a tank enters Regeneration or Standby the solenoid is energized. Pressure from solenoid port 1 passes to port 2. The diaphragm valve #2 will close.

When a tank enters In Service the solenoid is de-energized. The inlet pressure to solenoid port 2 is stopped. The diaphragm valve is vented through solenoid port 2 to port 3 (drain). The valve #2 opens.

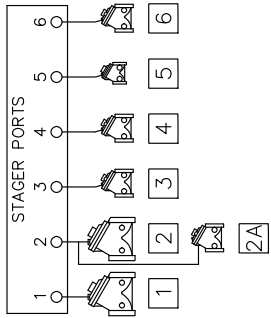

NOTCH POS.	FUNCTION	PORTS VENTED (NOTE 1)	VALVES OPEN
A 4	SERVICE	1,2	1,2
B			
C 1	BACKWASH	3,4	3,4,2A
D			
E 2	BRINE	5,6	5,6,2A
F 3	RINSE	1,6	1,6,2A

Note: All valves normally open except optional valve 2A.

		CONTROL TUBING DIAGRAM	
		MR W/PARKER SOLENOID OVERRIDE	
FRAC.#	DEC.#	FILE ID.	SHEET 1 OF 1
DRN.	BCD	SCALE N/A	
APP'D.	VB	DRAWING NO.	REV. 0
DATE	6-2-11	DRAWING NO.	A2006055
MULTITANK W/MX III OPTION			
REVISIONS			
NO.	DATE	BY	REMARKS

INSTALLATION INSTRUCTIONS

GENERAL INFORMATION

Before beginning installation, thoroughly review the following instructions to familiarize yourself with the general placement and identification of all components. These instructions are written for a single unit installation, but they also generally apply to twin and triple units.

Refer to specific equipment layout drawing, water meter installation instruction, and interconnecting electrical wiring diagram for your system.

Catalog softeners are shipped fully assembled with face piping and controllers. Care must be taken not to damage valves or controllers during uncrating and installation. During unpacking the brine tank miscellaneous parts are shipped inside the brine tank. These parts include hardness test kit, injectors, extra manuals and other parts that may apply to your particular system. Care should be taken when unpacking the brine tank.

NOTES:

- Install the piping conforming to federal, provincial, and local codes.
- Union or flanges are recommended at the control valve's inlet, outlet, and drain connections
- To enhance the monitoring of the system's performance sample valves and pressure gauges are be installed at the inlet and outlet piping to each control valve.
- If distance of drain line is over a 10 ft. vertical, or 25 ft. horizontal run, increase drain line one pipe size over that provided on the control valve.
- Do not make a direct connection to the drain. Provide an air gap of at least four times the diameter of the pipe to conform to sanitation codes and to permit observation of the flow.
- It is not recommended that an overhead or a long horizontal drain run be used. The increased backpressure will cause problems when drawing brine.

PIPING INSTALLATION:

1. Install piping as shown on the layout drawing. Include unions and shut-off valves on the inlet and outlet of each softener. Also, include a shut-off valve for each injector provided with the system. It is recommended that a union be installed in each softener drain-line to facilitate cleaning the backwash flow control.
2. Do not reduce drain-line pipe size. Do not install a shut off valve in the drain-line. Provide an air gap in the drain line in accordance with local codes (minimum four (4) pipe diameters).
3. If your system has a water meter thoroughly read the meter instructions manual located in the back of this manual before installing any water meters or flow sensors,. Water meters typically must be installed in a particular manner (i.e. horizontal, plane or with recommend pipe lengths) to function properly.
4. After the piping has been completed, make sure to close all isolation valves.

INSTALLATION INSTRUCTIONS

SOFTENER LOADING

Do not begin loading until you have confirmed all of the required media is on site. Locate your unit on the Specification Table for the correct amount of gravel and resin per tank and separate quantities.

Before loading, visually check the lower distributor for shipping damage. All radial arms and baskets strainers are in place and pointing downward. Tighten any loose laterals. Do not load tank if there is damage is evident. Call the factory if any damage is observed.

Care should be exercised in the loading of the gravel in order to insure that the distributors are not damaged. The equipment provided has a PVC lower distributor system.

GRAVEL LOADING - (Load First)

1. Slowly open the inlet valve and fill the tank half way or as full as possible with water. There might be a flow of water to drain.
2. Slowly and gently pour the gravel marked for the mineral tank into the unit.
3. Drain the tank down until the gravel and water levels are the same.
4. Carefully level the gravel before loading the resin.

RESIN LOADING

1. Reopen the inlet valve and fill the tank to 1/3 to 1/2 full of water.
2. Pour the quantity of resin marked for the tank in through the top opening.
3. Reopen the inlet valve and fill the tank with water to the top access opening.
4. Close and secure the top access opening.
5. Open inlet valve and continue to fill the tank with water until it is fully pressurized.

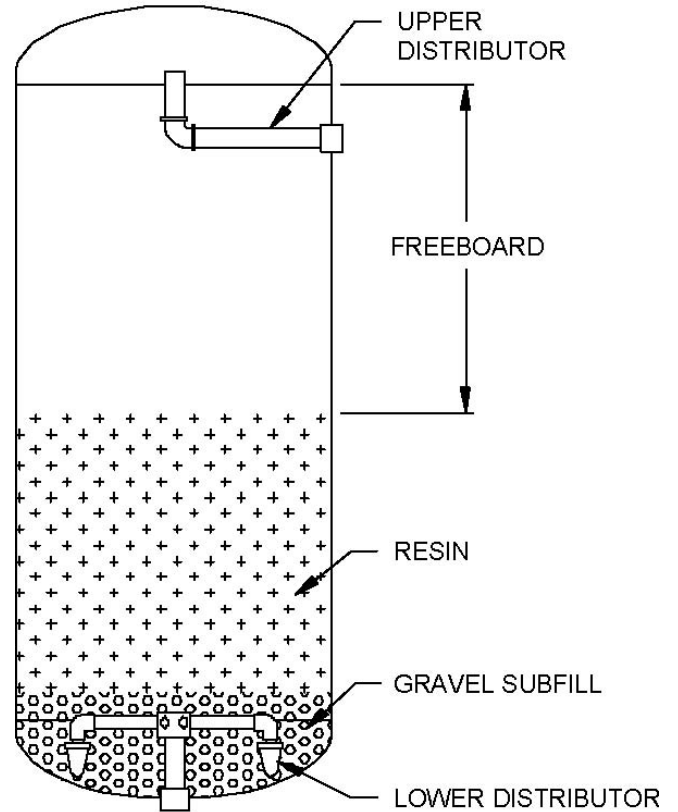

INSTALLATION INSTRUCTIONS

BRINE TANK INSTALLATION

1. The brine tank should be installed on a smooth level surface. If none is available, the tank should be placed on a smooth piece of exterior plywood and leveled by placing shims underneath the plywood.
2. Make sure that the salt shelf inside the tank is level and that the brine well is near to vertical as possible. Check the specifications table and make sure that the float setting is the proper height for the model provided. Brine tanks are shipped with the float set for maximum salting. If incorrect, slide the float to the proper setting. Float should be approximately one inch above grid plate.
3. Place brine valve into the brine well and set at the bottom of the brine tank. Note: If minimum brine draw is desired, remove the pipe nipple and coupling from the brine assembly. Install remaining brine valve assembly into elbow using Teflon tape or Teflon paste, and set float to minimum salt level see Specification Table for settings. Place brine valve into brine well. Brine valve assembly will not sit on bottom of brine tank.
4. Connect the brine valve to the brine injector. Open the manual injector feed water valve and allow the brine tank to fill with water. To speed this process the tank can be filled with a garden hose to about 2” below the platform. The tank will continue to fill until the float rises and shuts of the flow (approximately 1” above the platform).

Note: In the process of making brine for the first regeneration, the solution volume will increase (one gallon of water will be 1.2 gallons of brine). The final level of the liquid will be several inches above the platform.

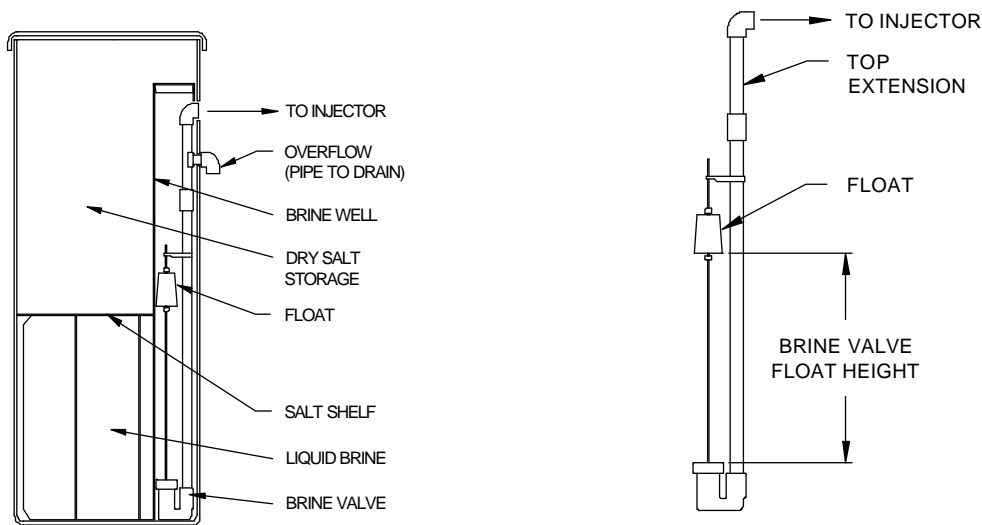

5. If the refill water shuts off below the platform or too far above the platform, the brine valve should be removed and the float adjusted up or down until it shuts off approximately 1” above the platform. Place the brine well cap seal in place and open the manual valve in the brine line to the softener tank.

START-UP INSTRUCTIONS

Before proceeding to start-up:

- Make sure the unit is properly installed with all piping complete
- All of the required media has been properly loaded in the tank
- Read the controls section located in this manual
- Do not fill Brine Tank with salt

With all piping and installation completed, and with the mineral in the tank, proceed as follows:

1. Open the manual by-pass valve. The manual inlet and outlet valves are to remain closed.
2. Connect the power to the NXT controller. The controller display window will light up.
3. Verify the following and change if required.
SYSTEM 7 is displayed in the window for twin alternating systems
 The **K FACTOR** is correct for your unit size

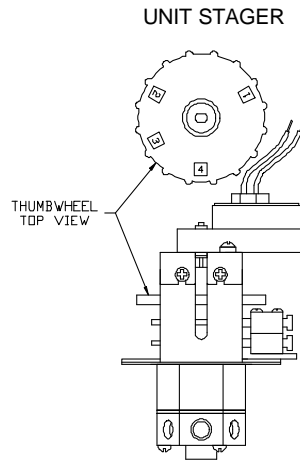

4. Open the cover of the enclosure and manually rotate the stager to the #1 (**BACKWASH**) position. The stager motor will rotate back to the #4 (**SERVICE**) position. This is done to confirm the controller's homing signal is operational.
5. Press and hold the **EXTRA CYCLE** button on the front of the controller. This will advance Unit 1 to the backwash step. The Unit 1 stager should rotate to the step 1 (**BACKWASH**) position.
6. Slowly open the softener's manual inlet supply valve. Do not open fully. Full flow of water could cause loss of media. Continue to fill slowly until all air is expelled and only water flows to the drain. Water will enter from the bottom of the resin tank as air is expelled from the top drain. If the system is supplied with an air vent make sure that the valve is open during this process.
7. When only water flows to the drain and out the air vent (if applicable), open the manual inlet valve all of the way. Backwash until the water looks clean when caught in a container.
8. Advance Unit to the brine/slow rinse step by pressing and holding the **EXTRA CYCLE** button. The stager should rotate to the STEP 2 (**BRINE/SLOW RINSE**) position. There will be a slow flow to the drain.
9. While the unit is in the Brine/Slow Rinse position, check the level in the brine tank. The level should be dropping at a slow rate (approximately 2" per minute).

START-UP INSTRUCTIONS - (cont'd)

10. Advance Unit to the Fast Rinse position by pressing and holding the **EXTRA CYCLE** button. The stager should rotate to the STEP 3 (**FAST RINSE**) position. There will be a high flow of water to the drain. Allow the water to flow to the drain until clear. During this time, the brine tank will fill with water until the float closes the brine tank valve. Check that all brine fittings are tight and that the water level in the brine tank is according to the unit specifications.
11. Advance Unit to the service position by pressing and holding the **EXTRA CYCLE** button. The stager should rotate to STEP 4 (**SERVICE**) position. There will be no flow of water to the drain.
12. Fill the brine tank with the proper amount and type of salt recommended for use with the system. See **RECOMMENDED TYPES OF SALT**.
13. Close the manual by-pass valve and open all outlet valves fully. The system is now in service.

VOLUME REMAINING/BATCH CALCULATION

HOW TO CALCULATE SOFTENER'S TREATED WATER CAPACITY

"Batch size" is the term used for the amount of water passing through and being softened by the water softener between regenerations. This is a simple calculation provided two pieces of information are known:

- Size of the water softener in grains (i.e. MR-600 has 600,000 grains capacity per tank).
- Hardness of the raw water being treated by the water softener.

SAMPLE CALCULATION

Example:

MR-600-2 – Total capacity available is 600,000 grains. Water hardness is 20 grains per gallon.

BATCH SIZE

Batch size = Grain capacity of softener divided by grains per gallon of hardness

BATCH SIZE EQUATION:

$$\text{Batch Size} = \frac{\text{Capacity of Softener (grains)}}{\text{Hardness of Water (grains per gallon)}}$$

Capacity of Softener = 600,000 grains

Water Hardness = 20 grains per gallon

Unit is a model MR -600 softener

The hardness of the water was measured to be 20 grains per gallon

Using our equation take $600,000 \div 20 = 30,000$ gallons.

For immediate regeneration type meter control the meter setting would be at 30,000 gallons. Commonly this value is adjusted to 90 percent of the actual value (in this example 27,000 gallons) to assure not over-running the softener.

10% Safety factor - reserve capacity = 3,00 gallons.

30,000 gallons – 3,000 gallons = **27,000 gallons (batch size/volume remaining)**

GENERAL SOFTENER OPERATION

Hard water passes through the valve manifold into the top of the softener tank. It flows downward through the mineral bed and out through the bottom of the tank to service. As the water passes through the mineral bed, the hardness present is removed through the process of ion exchange and at the same time sediment present is removed by filtration action of the mineral. Once the mineral has extracted all the hardness it can, it must be regenerated and have its capacity restored by the following procedure:

SERVICE

1. Service – Hard water enters the softener, is treated and exits the system.

REGENERATION

2. Backwash: The flow through the mineral bed is reversed and allowed to flow to drain. The up-flow action washes any sediment or foreign material collected in the unit out to drain. At the same time the mineral itself is restratified, thereby eliminating any possibility of channeling (approximately 10 minutes).
3. Brine Draw: The flow through the unit is returned to down-flow to drain at a slow controlled rate and during the first stage of this step the brine is injected to react with the mineral and restore its softening capacity (approximately 20 minutes).
4. Slow Rinse: The flow through the unit is a slow flow of water to rinse all of the exchanged hardness and salt from the unit (approximately 40 minutes).
5. Fast Flush: The downward flow to drain in this step is increased to a high rate which will repack the mineral bed and remove the last traces of salt and hardness from the regenerated equipment just before its return to service (approximately 6 minutes)

HOW THE STAGER FUNCTIONS

The regeneration of the equipment provided is carried out through the redirection of flow through the valve manifold. This manifold consists of individual diaphragm valves, which are controlled by the hydraulic stager mounted at the bottom of the stager controller. The stager applies or relieves water pressure to close or open valves as required. When water pressure is applied to the top of a diaphragm valve, it forces a diaphragm in causing it to close the seat assembly. When pressure is relieved from the top of the valve, by venting it to drain through the stager, the water pressure under the diaphragm forces it out thereby opening the seat assembly.

Note: If stager somehow gets out of sequence either:

- Rotate thumb wheel in direction of arrow.
- Be patient, unit will return to service position and be in sequence within 2 hours.

FLOW DIAGRAM - WATER SOFTENERS

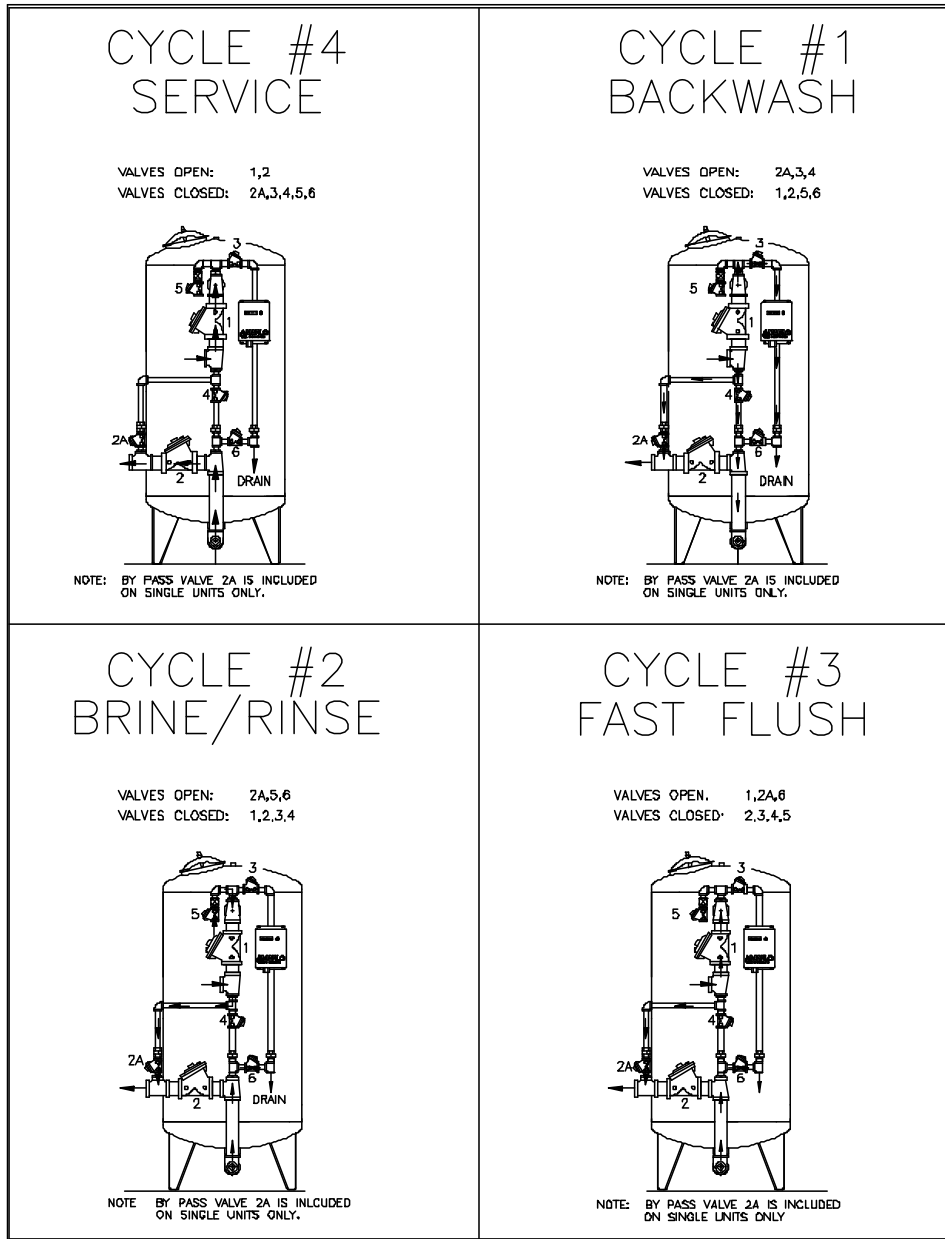

BRINE MAKER OPERATION

The brine-maker is an automatic brining system, which is easily adjusted to provide maximum operating efficiency of your water softener. It is a combination salt storage and brine-measuring tank complete with an automatic valve.

The brine-maker consists of:

1. An open brine tank with a platform dividing it into sections:
 - The upper section is used for dry salt storage
 - The lower section for brine storage.
2. An automatic brine valve which is housed in a closed tube or “well”.

After each regeneration, water flows from the brine valve and into the brine tank. When the water level rises slightly above the platform, a float closes the automatic brine valve. Salt slowly dissolves to form concentrated brine. As brine is formed, the liquid volume increases and the level rises in the salt. The resulting level may be 2 to 10 inches above the platform depending on the amount of salt for regeneration. During regeneration, the brine injector creates suction, which opens the brine valve and draws into the softener tank. When the brine level falls below the brine valve, the valve seats and prevents air from entering the system.

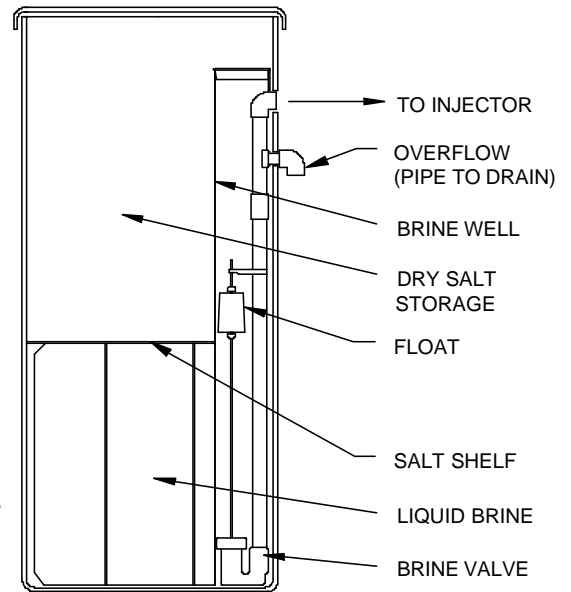

RECOMMENDED TYPES OF SALT

Only purified salt should be used in the brining system. Palletized salt (“Button”, “Nugget”, and “Pellet”) or block salt (free binders) is recommended. Do not use granulated salt, as it will fall through the platform screen.

Rock salt is not normally recommended. Most rock salt contains sludge-forming insoluble that collect on the platform and prevents proper salt-water contact.

Only salt containing 0.5% or less of insolubles will provide continued satisfactory operation. If, salt with more insolubles is used, the brine maker will require periodic cleaning.

MINIMUM SALTING ADJUSTMENT

Minimum salting is the most efficient use of salt. But it does minimize the capacity of the unit, which will decrease the time between regenerations. Only make this adjustment after the unit has completed a brine tank refill step and the water level was checked to be above the salt platform. Follow these instructions to adjust your unit to regenerate with minimum salt usage.

- Adjust brine tank refill time to the minimum setting according to the specification table. Refer to the “Setting the regeneration cycle timer page.
 - Monitor the water daily for hardness. It may also be necessary to adjust the regeneration frequency, since the capacity of the unit has changed.
1. Remove brine valve assembly from brine well.
 2. Remove air check from assembly.
 3. Shorten the riser tube by removing the top extension pipe.
 4. Reassemble brine valve assembly.
 5. Reinstall the assembly into the brine well. The assembly will no longer reach the bottom of the brine tank.

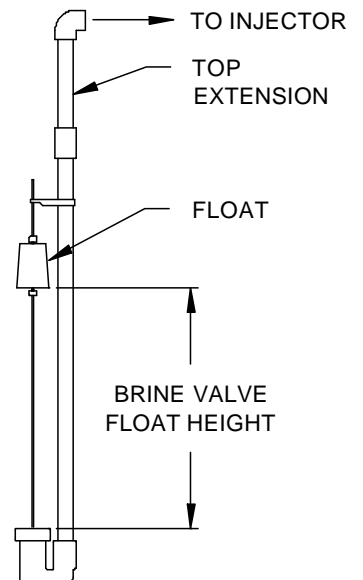

FEATURES OF THE MX III CONTROLLER

System Number	System Description	# of Tanks	Connect meter and/or remote regeneration input to...	Regeneration Type	Service Outlet Valve controlled by...	Operation Discussion
4	Single Unit	1	#1 Controller	Time Clock: No Meter Immediate: One Meter Delayed: One Meter Remote Signal Start: No Meter	Stager (no solenoid required)	Single tank configuration. During Regeneration no water available to service unless optional bypass valve #2A installed.
5	Interlocked	2, 3, or 4	Each Controller	Immediate: All Meters Remote Signal Start: No Meter	Stager (no solenoid required)	All tanks in parallel supplying treated water. Each unit in the system will have its own flow meter/sensor input. The control will delay the start of Regeneration if another unit is already in Regeneration. Once that unit has completed a Regeneration cycle, and has returned to Service, the unit with longest regeneration queue time will begin Regeneration. No more than one unit will be in Regeneration at a time.
6	Series Regeneration	2, 3, or 4	#1 Controller Only	Immediate: One Meter Delayed: One Meter Remote Signal Start: No Meter	Stager (no solenoid required)	All tanks in parallel supplying treated water. Only #1 control will monitor flow meter/sensor input. When a regeneration is required for the system, it will regenerate valve address #1 first, immediately followed by #2, then #3, then #4 if installed. No more than one unit will be in Regeneration at a time.
▲ 7	Twin Alternating	2	#1 Controller Only	Immediate: One Meter Remote Signal Start: No Meter	Solenoid	One tank online supplying treated water, one tank in Standby. Only #1 control will monitor its flow meter/sensor input. Regeneration of a unit will begin after the other control has left Standby and returned to Service. When the Regeneration cycle is complete, the regenerated unit will enter Standby. Standby on each tank is controlled by a solenoid connected to the service outlet valve of that tank.
9	Multiple Tank Alternating	2, 3, or 4	Each Controller	Immediate: All Meters Remote Signal Start: No Meter	Solenoid	One, two, or three tanks online supplying treated water, one tank in Standby. Meter/sensor input is required on each tank. Regeneration of a unit will begin after the other control has left Standby and returned to Service. When the Regeneration cycle is complete, the regenerated unit will enter Standby. Standby on each tank is controlled by a solenoid connected to the service outlet valve of that tank.
14	Demand Recall	2, 3, or 4	Each Controller	Immediate: All Meters	Solenoid	Meter/sensor input is required on each tank. Unit #1 will begin in Service with #2, #3, and #4 (if installed) will begin in Standby. At least one unit is in Service at all times. When flow rate to the Primary Service Unit increases to a user specified rate, the next unit in sequence will move from Standby to Service. As the flow rate falls below the user specified rate subsequent tanks will return to Standby. When the Primary Service Unit regenerates, the next unit in sequence will become the new Primary Service Unit. As each unit's capacity is reached the controller will initiate a Regeneration of that unit. Depending on the number of units in the system, and flow rate demand the regenerated unit will then be placed either into Standby or Service. Only one unit will be in Regeneration at a time.

USER MODE PROGRAMMING FLOW CHART

NOTE: User Mode is only displayed when a metered option is chosen under System Type.
Depending on current option settings, some displays cannot be viewed or set.

Entering User Mode:

Hold the Up and Down buttons for 5 seconds.

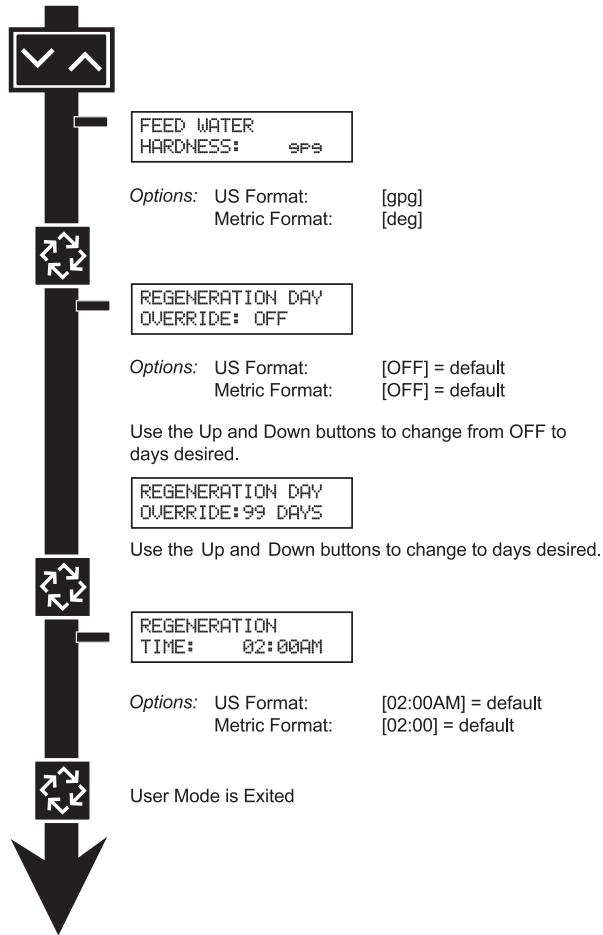

NOTE: User Mode cannot be entered on the Lag unit for System 6.

1. Enter User Mode

Press and hold the Up and Down buttons for 5 seconds.

2. Set Language Option

Press up or down to select language.

Press the Extra Cycle button to proceed to the next step.

3. Set Feed Water Hardness

Press the Shift, Up, and Down buttons to move the cursor and change the value of the numbers.

Press the Extra Cycle button to proceed to the next step.

NOTE: Only displayed when a metered option is chosen under System Type.

4. Set Regeneration Day Override

To turn on and set the days, press the Down button.

Press the Shift, Up, and Down buttons to move the cursor and change the value of the numbers.

Press the Extra Cycle button to proceed to the next step.

5. Regeneration Time

Press the Shift, Up, and Down buttons to move the cursor and change the value of the numbers.

Press the Extra Cycle button

6. End of User Programming Mode

NETWORK/COMMUNICATION CABLES & CONNECTIONS

Use a CAT5 Network/Communication cable.

1. Connect the network/communication cable first before programming.
2. The maximum cable length between timers is 100 feet.
3. Connect each unit together from one communication port to the next communication port. It does not matter which one goes to the next one.

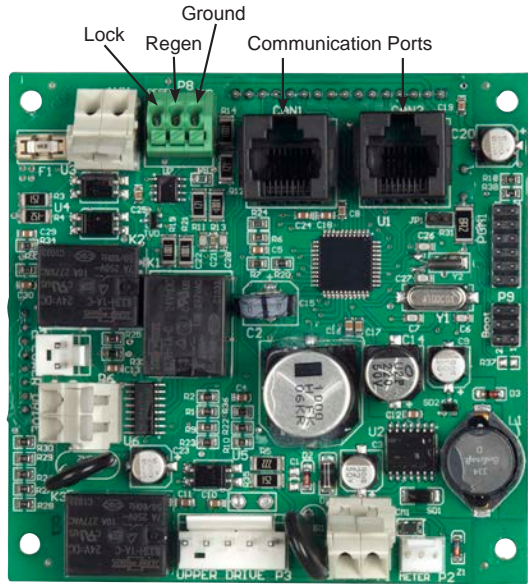

NXT Circuit Board

The number of network/communication cables needed for setup is one less than the total number of valves.

- Two-Unit System:** One network/communication cable
- Three-Unit System:** Two network/communication cables
- Four-Unit Systems:** Three network/communication cables

NETWORK TIMER SYSTEM CONFIGURATION WIRING

System 7 Twin Alternating

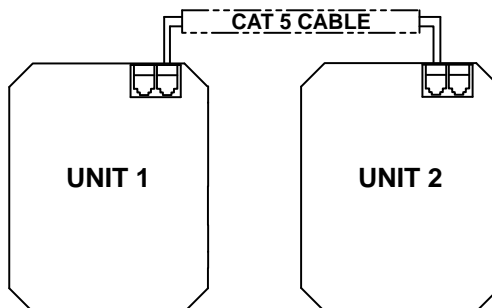

MX III CONTROLLER OPERATION

SETTING THE TIME OF DAY

NOTE:

Set Time of Day on the Lead Unit (#1) and the rest of the units in the system will populate with the Time of Day within 10 seconds.

1. Press and hold the Up or Down button for 2 seconds.
2. Press the Shift button to select the digit you want to modify.
3. Press the Up or Down buttons to adjust the value.
4. Press the Extra Cycle button to return to the normal display screen, or after a 5 second timeout.

NOTE:

The “D” button (Diagnostic) can be pressed to exit without saving.

MANUALLY INITIATING A REGENERATION

1. When timer is in service, press the Extra Cycle button for 5 seconds on the main screen.
2. The timer advances to Regeneration Cycle Step #1, and begins programmed time count down.
3. Press the Extra Cycle button once to advance valve to Regeneration Cycle Step #2 (if active).
4. Press the Extra Cycle button once to advance valve to Regeneration Cycle Step #3 (if active).
5. Press the Extra Cycle button once to advance valve to Regeneration Cycle Step #4 (if active).
6. Press the Extra Cycle button once to advance valve to Regeneration Cycle Step #5 (if active).
7. Press the Extra Cycle button once more to advance the valve back to in service.

NOTE:

A manually initiated or queued regeneration can be cleared by pressing the Extra Cycle button for less than 5 seconds. A system queued regeneration can only be cleared by stepping through a manual regeneration. If regeneration occurs for any reason prior to the delayed regeneration time, the manual regeneration request shall be cleared. Pressing the Extra Cycle button while in regeneration will cause the upper drive to advance to the next step immediately.

CONTROLLER OPERATION DURING REGENERATION

In the Regeneration Cycle Step display, the controller shows the current regeneration cycle number the valve is on, or has reached, and the time remaining in that step. Once all regeneration steps are complete the timer returns to in Service and resumes normal operation.

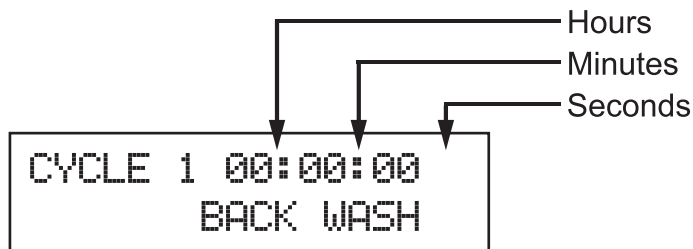

Example: 12 Minutes Remaining in Cycle 1 (Back Wash)



Press the Extra Cycle button during a Regeneration Cycle to immediately advance the valve to the next cycle step position and resume normal step timing.

FLOW METER EQUIPPED CONTROLLER

- During normal operation, the Time of Day screen alternates with the error screen (if errors are present).
- As treated water is used, the Volume Remaining display counts down from the calculated system capacity to zero. When this occurs a Regeneration Cycle begins if no other units are in regeneration.

MX III CONTROLLER OPERATION

CONTROLLER OPERATION DURING PROGRAMMING

The controller enters the Program Mode in standby or service mode as long as it is not in regeneration. While in the Program Mode the controller continues to operate normally monitoring water usage. The controller's programming is stored in memory permanently.

CONTROLLER OPERATION DURING A POWER FAILURE

All program settings are stored in permanent memory. Current valve position, cycle step time elapsed, and time of day are stored during a power failure, and will be restored upon power re-application. Time is kept during a power failure, and time of day is adjusted upon power up (as long as power is restored within 12 hours).

NOTE:

A flashing Time of Day display indicates a power outage. The flashing of the time of day can be stopped by pressing any button on the display.

REMOTE LOCKOUT

The controller does not allow the unit/system to go into Regeneration until the Regeneration Lockout Input signal to the unit is cleared. This requires a contact closure to activate the unit. The recommended gauge wire is 20 with a maximum length of 500 feet. See P4 remote inputs in the wiring diagrams in the service manual.

REGENERATION DAY OVERRIDE FEATURE

If the Day Override option is turned on and the valve reaches the set Regeneration Day Override value, the Regeneration Cycle starts if no other unit is in Regeneration. If other units are in regeneration, it is added to a regeneration queue. This occurs regardless of the remaining volume available.



WARNING

Transformer must be grounded and ground wire must be terminated to the back plate where grounding label is located before installation.

CONTROLLER DISPLAY FEATURES

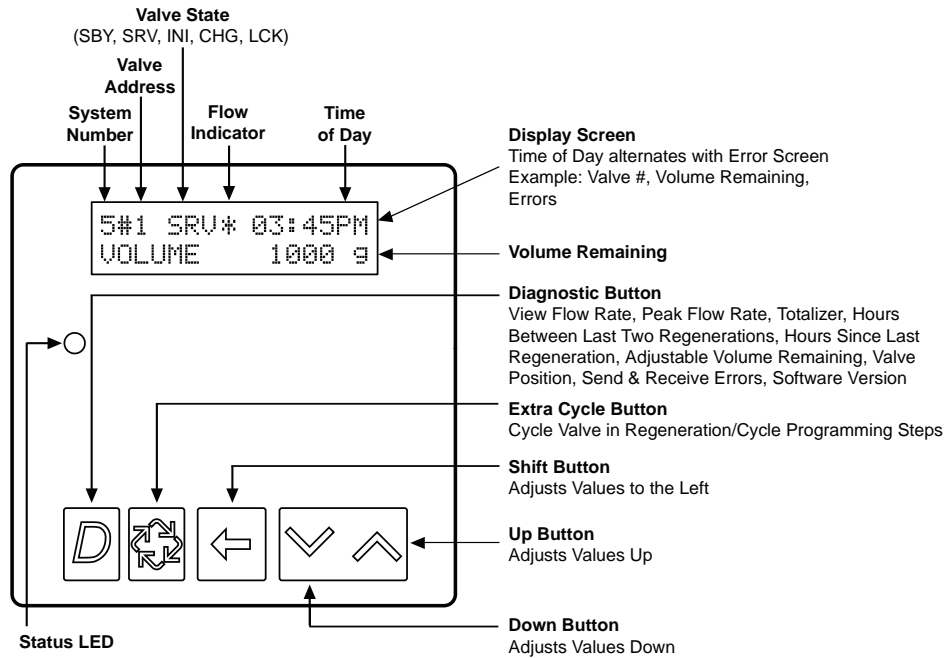

VALVE STATE:

INI (Initializing)

INI will display on the screen for 30 to 45 seconds when initializing after a power failure reset or programming.

RGQ (Regeneration Queued)

RGQ indicates that the reserve has been entered in a delayed system and regeneration has been queued. When in the main screen, press the Extra Cycle button to toggle service (SRV) with RGQ.

Service (SRV)

SRV will display when the unit is in service.

LCK (Lock)

Lock will be displayed when the terminal/remote input block P4 on the circuit board is switched to "lock". See the "Network/Communication Cables & Connections" section of this manual.

LED STATUS LIGHTS:

Blue LED:

Illuminates while the unit is in service and no errors exist. The unit will always be in service unless a regeneration trigger has occurred (green LED light will be displayed).

A **blinking blue light** indicates the timer is in service, and queued for regeneration.

Green LED:

Illuminates when the unit is in Regeneration mode, unless an error condition exists.

A **blinking green light** indicates the timer is in standby, and not in regeneration.

Red LED:

Illuminates when there is an error.

FLOW INDICATOR:

A rotating line (appearing as a rotating star shape) will display on the screen when flow is going through the the meter.

CONTROLLER DISPLAY - SCREEN EXAMPLES

```
4# SRV 03:45PM
REGEN IN 07 DAYS
```

EXAMPLE:

In Service:
System 4 Time Clock

```
4# SRV* 03:45PM
VOLUME 1000 g
```

EXAMPLE:

In Service:
1. System 4 Flow Meter Initiated
or
2. System 4 Flow Meter Delayed

```
5#1 SRV* 03:45PM
VOLUME 1000 g
```

EXAMPLE:

In Service:
1. System 5 Flow Meter Initiated (Lead Unit)

```
5#3 SRV 03:45PM
VOLUME 1000 g
```

EXAMPLE:

In Service:
1. System 5 Flow Meter Initiated (Lag Unit #3)

```
6#1 SRV* 03:45PM
SYSVOL 4000 g
```

EXAMPLE:

In Service:
1. System 6 Flow Meter Initiated (Lead Unit)

TWIN ALTERNATING (SYSTEM 7) PROGRAMMING AND RANGES

Programming Parameters and Ranges

System Type	7 Alternating		Programming Parameter Ranges	
	1	2	Gallons	Liters
Valve Address	1	2	1 thru 2	
Select Language	x	x	English* , Espanol, Portugues, Deutsch, Francais	
System Size	x		1 thru 2	
Regen Type	x	x	Time Clock, Metered Delayed, Metered Immediate*	
Valve Type	x	x	2750, 2850, 2900, 3150, 3900, Stager*	
Regenerant Flow	x	x	Downflow* , Upflow, Upflow Fill First	
Remote Signal Start	x		Off, 00:00:01 - 01:39:00	
Display Format	x	x	US - Gallons	EU - Metric-Liters
Unit Capacity	x	x	1 - 9900000 Grains	1 - 198000 gCaCO3
Capacity Safety Factor	x	x	0- 50%	
Feed Water Hardness	x	x	1 - 199 Grains/Gallons	1 - 1999 mgL
Trip Point 1			0 - 997gpm	0 - 3997 Lpm
Trip Delay 1			30 - 99 Seconds	30 - 99 Seconds
Trip Point 2			Trip Point 1 + 1 - 998 gpm	Trip Point 1 + 1 - 3998 Lpm
Trip Delay 2			30 - 99 Seconds	30 - 99 Seconds
Trip Point 3			Trip Point 2 + 1 - 999 gpm	Trip Point 2 + 1 - 3999 Lpm
Trip Delay 3			30 - 99 Seconds	30 - 99 Seconds
Regeneration Day Override	x		Off, 1 - 99	
<i>Regeneration Time</i>	o	o	12:00 a.m. - 11:59 p.m.	00:00 - 23:59 Hour
Cycle 1	x	x	00:00:00 - 04:00:00	
Cycle 2	x	x	Off, 00:00:00 - 04:00:00	
Cycle 3	x	x	Off, 00:00:00 - 04:00:00	
Cycle 4	x	x	Off, 00:00:00 - 04:00:00	
Cycle 5	x	x	Off, 00:00:00 - 04:00:00	
Auxiliary Relay	u	x	Enabled, Disabled	
<i>Aux Relay Output Start</i>	c	c	00:00:01 to Total Regeneration Time - 1	
<i>Aux Relay Output End</i>	c	c	Start Time + 1 to Total Regeneration Time	
Chemical Pump	u		Enabled, Disabled	
<i>CPO Aux Relay Volume</i>	c		1 - 999 gallons	0001 - 9999 Liters
<i>CPO Aux Relay Time</i>	c		00:00:01 - 02:00:00	00:00:01 - 02:00:00
Flow Meter	x		1" 1.5" Paddle or Turbine, 2" Paddle, 3" Paddle, Generic*	
<i>Generic</i>	x		Enter Flow Meter Data	
<i>Maximum Flow Rate</i>	a		20 - 2000 GPM*	20 - 2000 LPM
<i>Add ___ Gallons or Liters</i>	a		1 - 255 Gallons*	001 - 255 Liters
<i>Every ___ Pulses</i>	a		1 - 255*	1 - 255

a - If Generic Flow Meter is chosen, then programming parameters will be viewed.
c - All Relay Output parameters programming will be viewed if Enabled.
o - Regeneration Time will only be viewed if Regeneration Day Override is used
u - If Auxiliary Relay is Enabled then Chemical Pump Relay will not be viewed or if Chemical Pump Relay is Enabled then Auxiliary Relay will not be viewed
*Indicates Required settings for Stager Controller

MASTER PROGRAMMING MODE FLOW CHART

NOTE: Depending on current option settings, some displays cannot be viewed or set.

Entering Master Programming Mode:

1. Press and hold the Shift and Up buttons for 5 seconds.
Press the Extra Cycle button once per display until all displays are viewed and Normal Display is resumed. Option setting displays may be changed as required by pressing either the Up or Down button. Use the Shift button to move one space to the left.
2. Depending on current valve programming, certain displays may not be viewed or set.

NOTE: If the “D” button is pressed while in master programming, no changes will be saved.

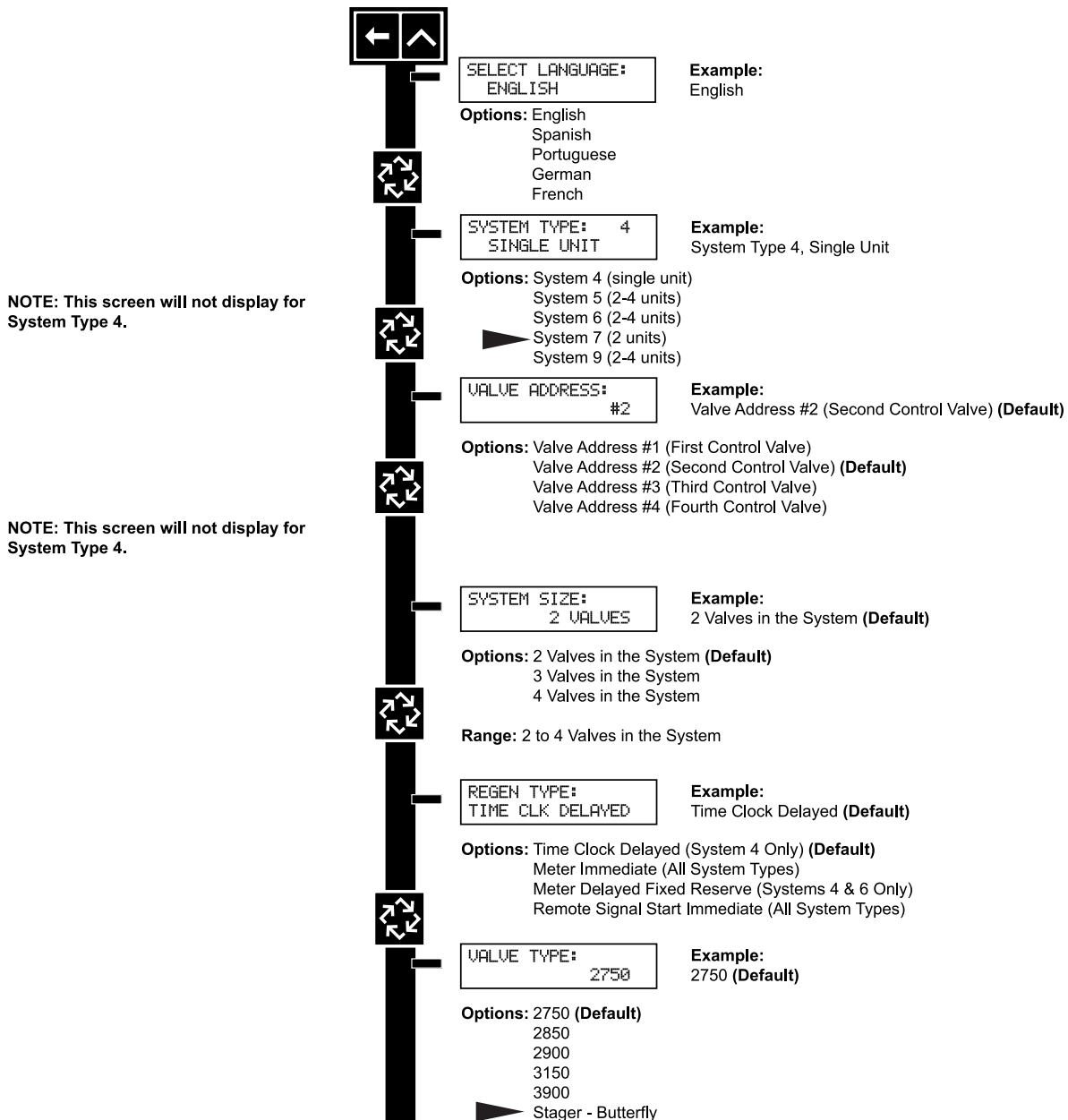

MASTER PROGRAMMING MODE FLOW CHART

NOTE: Depending on current option settings, some displays cannot be viewed or set.

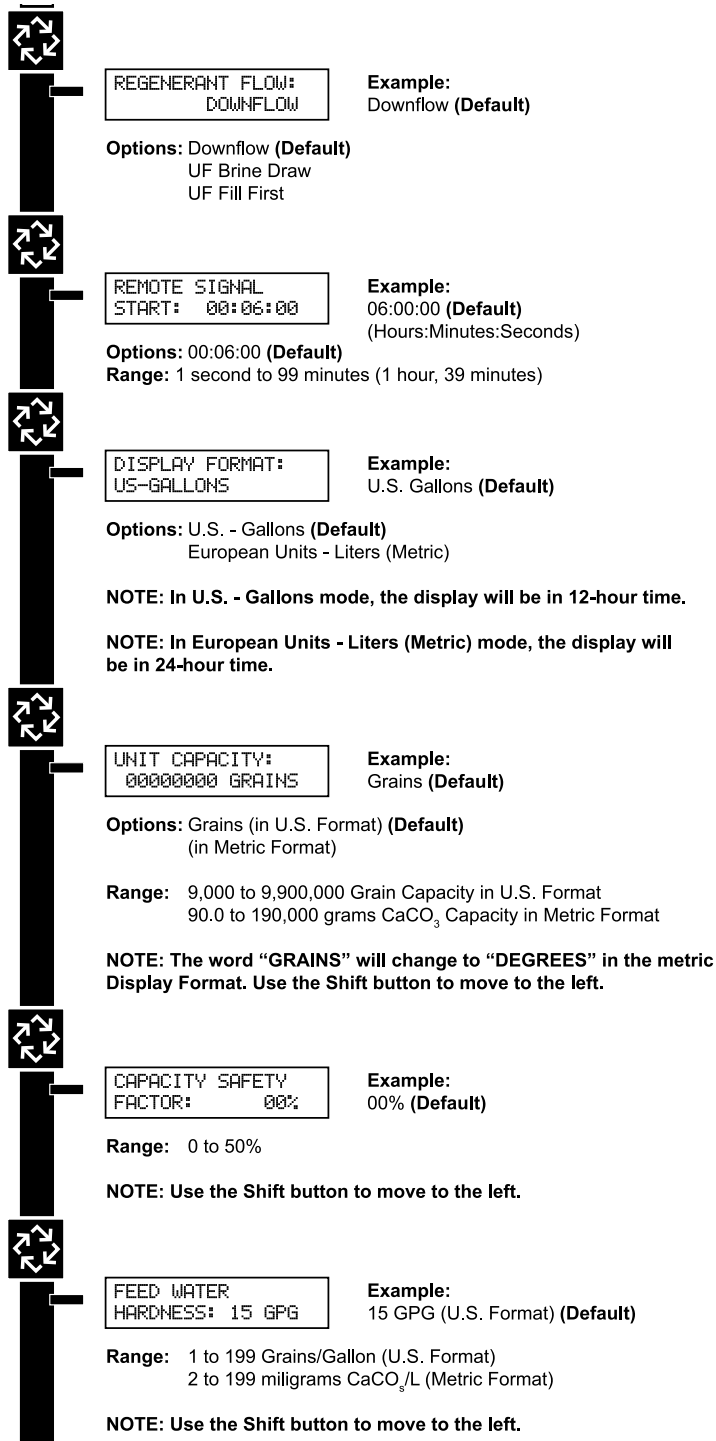

NOTE: This screen will only display on the lead unit for System Types 6 & 7. For all other System Types, it will display for all units.

CAUTION: Before entering Master Programming, please contact your local professional water dealer.

MASTER PROGRAMMING MODE FLOW CHART

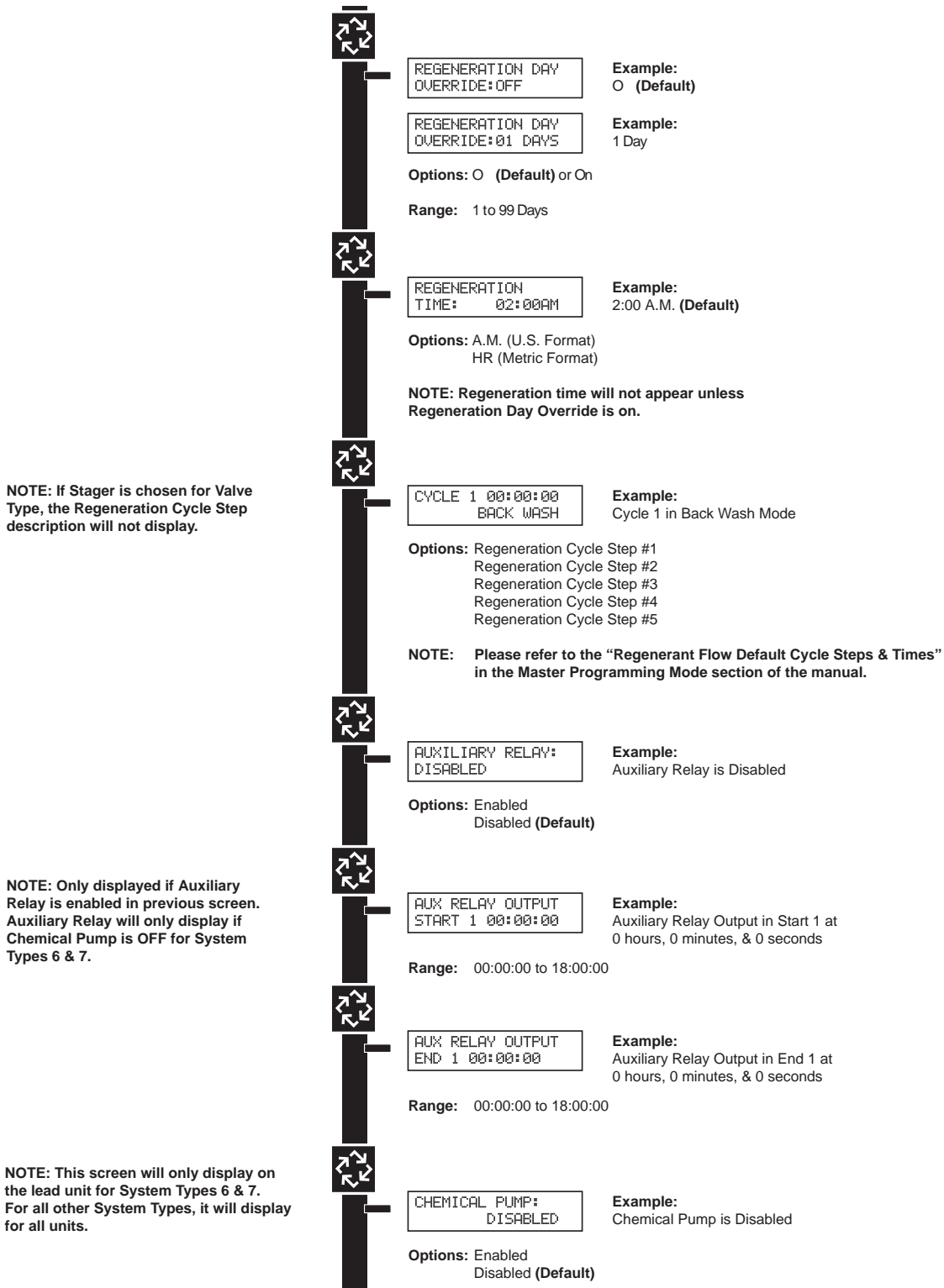

CAUTION: Before entering Master Programming, please contact your local professional water dealer.

MASTER PROGRAMMING MODE FLOW CHART

NOTE: Only displayed on units that physically have a meter (Lead always has a meter). Only shown if Auxiliary Relay is disabled on System Types 6 & 7.



CPO AUX RELAY
VOLUME: 000 g

Example:
Chemical Pump Auxiliary Relay
Volume at 0 Gallons

Range: 000 to 999 gallons in U.S. Format
0.000 to 9.999 m3 in Metric Format



CPO AUX RELAY
TIME: 00:00:00

Example:
Chemical Pump Auxiliary Relay at 0 Hours,
0 Minutes, & 0 Seconds

Range: 00:00:00 to 02:00:00

NOTES: Default flow meter type is based on the valve type. This screen will only display on the lead unit for System Types 6 & 7. All other system types it will display for all units.



FLOW METER:
1.0 PADDLE

Example:
1.0 Paddle Flow Meter

Options: 1.0 Paddle
1.0 Turbine
1.5 Paddle
1.5 Turbine
2.0 Paddle
3.0 Paddle
Generic

Options Only if Generic Flow Meter Chosen:



MAXIMUM FLOW
RATE: 0000 gpm

Example:
Maximum Flow Rate of 0 gpm

Range: 20 - 2,000 gpm (U.S. Format)
2.0 - 200.0 m3 (Metric Format)



ADD 01 GALLONS
EVERY 001 PULSES

Example:
Add 1 Gallon for Each Pulse in U.S. Format

Options: Gallons (U.S. Format)
Meter3 (Metric Format)

Range: 1 - 99 Gallons (U.S. Format)
0.1 - 09.9 M3 (Metric Format)
Pulses: 1 - 99



PROGRAMMING UNIT
PLEASE WAIT...

Example:
Master Programming Mode is Exiting



OPTIONS FOR GENERIC FLOW METER SETTING K-FACTOR TABLE

PIPE SIZE (in)	SIGNET 2536 FLOW SENSOR SETTINGS				CLACK METER (in)	MAX FLOW RATE (gpm)	K-FACTOR (Pulses per Gallon)
	MAX FLOW RATE (gpm)	TEE GALVANIZED	TEE PVC	SADDLE IRON			
1	49	213	352		1-1/2	75	37
1-1/4	76	128	177		2	150	20
1-1/2	110	94	118		3	350	8
2	195	59	67	54	AUTOTROL METER		K-FACTOR
2-1/2	306		43	38	(in)	(gpm)	(Pulses per Gallon)
3	440		27	23	1	25	65
					2	255	15

MASTER PROGRAMMING GUIDE

When the Master Programming Mode is entered, parameters can be set to make the timer(s) function as needed.

NOTE:

Depending on current option settings, some displays cannot be viewed or set.

Entering Master Programming Mode:

1. Press and hold the Shift and Up buttons for 5 seconds.
OR
2. Set the time of day display to 12:01 PM or 12:01HR (See the “Setting the Time of Day” section on the “Timer Operation” page). Then go to the main display screen, press the Up and Down buttons at the same time for 5 seconds.

Exiting Master Programming Mode:

1. Press the Extra Cycle button once per display until all are viewed. Master Programming Mode is exited and the normal display screen appears.
2. To exit the Master Programming Mode without saving, press the Diagnostic button.

NOTE:

If no keypad activity is made for 5 minutes while in the Master Programming Mode, or if there is a power failure, no changes will be made, and the unit will go back to the main display screen.

Resets:

Soft Reset: Press and hold the Up and Down buttons for 25 seconds until 12:00PM (or 12:00HR) appears. This resets all parameters except for the flow meter totalizer volume.

Master Reset: Hold the Extra Cycle button while powering up the unit. This resets all of the parameters in the unit. Check and verify the choices selected in Master Programming Mode.

1. Choice of Language

This option selects the language for programming and display.

1. Use Up or Down to select language.
2. Press the Extra Cycle button.



```
SELECT LANGUAGE
ENGLISH
```

2. System Type

This program type selects the system type (4, 5, 6, 7, or 9).

1. Use Up or Down buttons to adjust this value.
2. Press the Extra Cycle button.



```
SYSTEM TYPE: 4
SINGLE UNIT
```

3. Valve Address

This program step selects the valve address (1, 2, 3, or 4) within the network needed for each timer for communication. The #1 is the “master” or “lead” which contains programmed parameters, that will be used by all of the timer(s) in the network to control Regeneration, in Service, or Standby of all the valve(s) in the system.

1. Use Up or Down buttons to adjust this value.
2. Press the Extra Cycle button.



```
VALVE ADDRESS:
# 2
```

CAUTION: Before entering Master Programming, please contact your local professional water dealer.

MASTER PROGRAMMING GUIDE

4. System Type

This program step is used to set up the number of valves (1, 2, 3, or 4) in the system.

1. Use Up or Down buttons to adjust this value.
2. Press the Extra Cycle button.

```
SYSTEM SIZE:  
  2 VALVES
```

5. Regeneration Type

This program step is used to set up the trigger type.

1. Use Up or Down buttons to adjust this value.
2. Press the Extra Cycle button.

```
REGEN TYPE:  
TIME CLK DELAYED
```

6. Valve Type

This program step selects the valve type (2750, 2850, 2900s, 3150, 3900, Stager-Butterfly, or Stager-Notch Cam)

1. Use Up or Down buttons to adjust this value.
2. Press the Extra Cycle button.

```
VALUE TYPE:  
  2750
```

7. Regenerant Flow

This program step selects the regenerant flow type (Downflow, Upflow, or Upflow Fill First)

1. Use Up or Down buttons to adjust this value.
2. Press the Extra Cycle button.

```
REGENERANT FLOW:  
  DOWN FLOW
```

8. Remote Signal Start

This program step selects the remote signal start. Hours, minutes, and seconds can be changed. When Remote Signal Start is active, the main screen will display. The options are either Off or set to the desired time.

1. Use Up or Down buttons to adjust this value.
2. Press the Extra Cycle button.

```
REMOTE SIGNAL  
START:  00:00:00
```

```
5#1 SRV* 05:38PM  
SIGNAL  00:06:00
```

Example: Remote Signal Start set to 6 minutes.
If the Signal is detected continuously for 6 minutes, the display will count down to 0 and it will remotely start.

MASTER PROGRAMMING GUIDE

9. Display Format

This program step is used to set the desired volume display format. This option must be the same on all system units. U.S. will display volumes in gallons and is in 12 hour timekeeping. Metric will display volumes in liters and is in 24 hour timekeeping.

1. Use Up or Down buttons to adjust this value.
2. Press the Extra Cycle button.

```
DISPLAY FORMAT:  
US-GALLONS
```

10. Unit Capacity

This program selects the individual timer's total capacity of hardness that can be removed. The unit capacity is measured in grains if in U.S. mode and degrees in Metric mode.

U.S. Range: 9,000 to 9,900,000 Grains (Default = 300,000 Grains)

Metric Range: 90.0 to 199,000.0 grams CaCO₃ (Default = 300.0 grams CaCO₃)

1. Use the Shift button to select the digit you want to modify.
2. Use Up or Down buttons to adjust this value.
3. Press the Extra Cycle button.

```
UNIT CAPACITY:  
300000 GRAINS
```

11. Capacity Safety Factor

This program step is used to adjust the capacity of the system. This is a percentage by which the unit's capacity is reduced.

Range: 0 – 50% (Default = 0%)

1. Use the Shift button to select the digit you want to modify.
2. Use Up or Down buttons to adjust this value.
3. Press the Extra Cycle button.

```
CAPACITY SAFETY  
FACTOR: 00%
```

12. Feed Water (Hardness)

This program step is used to set the feed water hardness. The system will automatically calculate volume remaining based on the Unit Capacity, Capacity Safety Factor and Feed Water Hardness entered.

U.S. Range: 1 – 199 gpg (Grains per Gallon)(Default = 15)

Metric Range: 2 – 199 grams CaCO₃/Liter (Default = 30)

1. Use the Shift button to select the digit you want to modify.
2. Use Up or Down buttons to adjust this value.
3. Press the Extra Cycle button.

```
FEED WATER  
HARDNESS: 015 GPG
```

MASTER PROGRAMMING GUIDE

13. Regeneration Day Override

This program step sets the maximum amount of time (in days) the unit can be In Service without a Regeneration.

U.S. Range: 1 – 199 gpg (Grains per Gallon)(Default = 15)

Metric Range: 2 – 199 Degrees (Default = 30)

1. Use the Shift button to select the digit you want to modify.
2. Use Up or Down buttons to adjust this value.
3. Press the Extra Cycle button.

REGENERATION DAY
OVERRIDE: OFF

REGENERATION DAY
OVERRIDE: 01 DAYS

14. Regeneration Time

This program step sets time of day for a delayed regeneration to occur, or regeneration day override.

Default U.S.: 02:00 AM

Default Metric: 02:00 HR

1. Use the Shift button to select the digit you want to modify.
2. Use Up or Down buttons to adjust this value.
3. Press the Extra Cycle button.

REGENERATION
TIME: 02:00AM

15. Regeneration Cycle Steps

This program step programs the Regeneration Cycle step times 1 through 5. Please refer to the chart below for regenerant flow default cycle steps and times.

Regenerant Flow	Cycle 1	Time	Cycle 2	Time	Cycle 3	Time	Cycle 4	Time	Cycle 5	Time
Down Flow	Back Wash	10 Minutes	Brine & Slow Rinse	1 Hour	Rapid Rinse	10 Minutes	Brine Tank Fill	12 Minutes	Pause	N/A

16. Auxiliary Relay Output

The next two displays are part of a series of settings used to program the optional relay output. The first setting turns the output on/off during Regeneration only. The second turns the output on during Service only, every time a set volume of water used has accumulated.

AUXILIARY RELAY:
ENABLED

17. Timed Auxiliary Relay Output Window (Start & End Time Setting, If Auxiliary Relay is Enabled)

This option setting consists of two displays. The first display sets the turn-on time of the output, referenced to the start of the first Regeneration Cycle. The second display sets the output turn-off time, referenced again to the start of first Regeneration Cycle.

Start Time: Anytime During Regeneration (Except Last Minute of the Regeneration Time)

End Time: At start time, and anytime during the regeneration cycle.

AUX RELAY OUTPUT
START 00:00:00

AUX RELAY OUTPUT
END 00:00:00

MASTER PROGRAMMING GUIDE

18. Chemical Pump Auxiliary Relay Output Window

This option setting consists of two displays. The first display sets the volume of water flow at which the output turns on. The second display sets the time of the output.

U.S. Range: 0 – 999 Gallons (1 – 999 Seconds)

Metric Range: 0.00 – 9.99 m³ (1 – 999 Seconds)

Activate Output After Volume Set is Reached.

Use the Shift button to move one space to the left for each number entered.

Use Up or Down buttons to adjust this value.

Press the Extra Cycle button.

```
CHEMICAL PUMP:
      ENABLED
```

```
CPO AUX RELAY
VOLUME:   000  g
```

```
CPO AUX RELAY
TIME:    00:00:00
```

19. Fleck Flow Meter Size (Default to Valve Type)

This program step sets the size of the Fleck flow meter.

- 1.0" Paddle (2750 Default)
 - 1.5" Paddle (2850/2900 Default)
 - 2.0" Paddle (3150 Default)
 - 3.0" Paddle (3900 Default)
 - 1.0" Turbine
 - 1.5" Turbine
 - Generic Flow Meter (Non Fleck Brand)
1. Use Up or Down buttons to adjust this value.
 2. Press the Extra Cycle button.

```
FLOW METER:
      .75 PADDLE
```

**OPTIONS FOR GENERIC FLOW METER SETTINGS (Non-Fleck Brand)
K-FACTOR TABLE**

PIPE SIZE (in)	SIGNET 2536 FLOW SENSOR SETTINGS				CLACK METER (in)	MAX FLOW RATE (gpm)	K-FACTOR (Pulses per Gallon)
	MAX FLOW RATE (gpm)	GALVANIZED TEE FITTING	PVC TEE FITTING	IRON SADDLE FITTING			
1	49	213	352		1-1/2	75	37
1-1/4	76	128	177		2	150	20
1-1/2	110	94	118		3	350	8
2	195	59	67	54	AUTOTROL METER (in)	MAX FLOW RATE (gpm)	K-FACTOR (Pulses per Gallon)
2-1/2	306		43	38	1	25	65
3	440		27	23	2	255	15

20. Maximum Flow Rate

This program step sets maximum flow rate of the generic flow meter.

1. Press the Shift button to select the digit you want to modify.
2. Press the Up or Down buttons to adjust this value.
3. Press the Extra Cycle button.

```
MAXIMUM FLOW
RATE:   0000  GPM
```

CAUTION: Before entering Master Programming, please contact your local professional water dealer.

MASTER PROGRAMMING GUIDE**21. Pulses per Gallon/Liter**

This program step sets the pulses per gallon/liter for generic flow meters.

1. Press the Shift button to select the digit you want to modify.
2. Press the Up or Down buttons to adjust this value.
3. Press the Extra Cycle button.

```
ADD 01 GALLONS  
EVERY 001 PULSES
```

22. End of Master Programming Mode

```
PROGRAMMING UNIT  
PLEASE WAIT...
```

CAUTION: Before entering Master Programming, please contact your local professional water dealer.

DIAGNOSTIC MODE FLOW CHART

Entering Diagnostic Mode:

1. Push and release the “D” button.
2. Press the Extra Cycle button once per display until all displays are viewed and Normal Display is resumed.
3. Push and release the “D” button at anytime during diagnostic mode and the timer will exit the mode.
4. Depending on current valve programming, certain displays may not be able to be viewed or set.

NOTE: If a System 6, Unit#1 of “Tank Remaining” will display “System Remaining”).

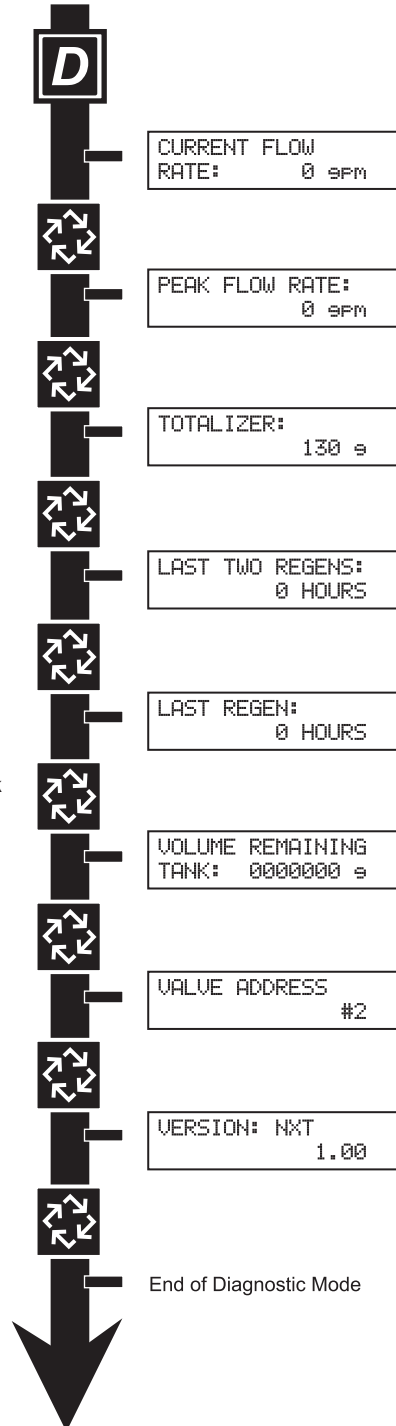

DIAGNOSTIC PROGRAMMING GUIDE

When the Diagnostics Mode is entered, all available displays are viewed as needed. Depending on current option settings, some displays cannot be viewed.

Overview Diagnostic Mode

The current diagnostic will be displayed until Extra Cycle key is pressed. There is no time limit on each display. The timer will display individual valve information, not system information. In the event of regeneration occurring while displaying diagnostics, the regeneration step and time remaining will be displayed. When regeneration has been completed, the display will return to the normal Time of Day display.

Overview Diagnostic Mode

Push and Release the “D” button to enter. Pressing the Extra Cycle button will move to the next diagnostic to be displayed. Push the Extra Cycle button once per display until all are viewed. Pressing the Diagnostic button, while in the Diagnostic Mode, will cause the unit to leave the Diagnostic Mode and return to the normal time of day display.

Current Flow Rate

Flow Rate for this particular Timer will be calculated and displayed. Flow rates will be calculated every second. The display updates once per second. Flow rates are dependent upon the meter used.

- **1” Paddle Meter Maximum Flow Rate:** 75 gpm (.28 m3/m)
- **1.5” Paddle Meter Maximum Flow Rate:** 90 gpm (.34 m3/m)
- **2” Paddle Meter Maximum Flow Rate:** 175 gpm (.66 m3/m)
- **3” Paddle Meter Maximum Flow Rate:** 350 gpm (1.32 m3/m)
- **1” and 1.5” Turbine Meter:** 75 gpm

1. Press the Extra Cycle button.



```
CURRENT FLOW
RATE:      0 GPM
```

Peak Flow Rate

The Peak Flow Rate since the last regeneration will be captured.

- **Range:** 0 to Maximum Number

1. Press the Extra Cycle button.



```
PEAK FLOW RATE:
              0 GPM
```

Totalizer

The total volume of treated water that passes through a meter will be counted.

NOTE: The user cannot edit below the current volume remaining.

1. Reset to zero by holding the Up and Down arrow keys for 5 seconds during the Totalizer display.
2. Press the Extra Cycle button.



```
TOTALIZER:
          00000000 g
```

Hours Between Last Two Regenerations

The hours between the last two regenerations will be saved and displayed.

1. Depress the Extra Cycle button.



```
LAST TWO REGENS:
              0000 HOURS
```

DIAGNOSTIC PROGRAMMING GUIDE

Hours Since Last Regeneration

The hours since the last regeneration will be saved and displayed.

1. Depress the Extra Cycle button.

```
LAST REGEN:
      0000 HOURS
```

Volume Remaining (This Tank Only)

Volume remaining in the current tank will be adjustable when displayed in this mode. Regeneration will occur if set to zero.

NOTE: Volume Remaining will not display for System Type 6.

The maximum ranges are the same as the maximum volume calculated on the main screen.

1. Press the Shift button to select the digit you want to modify.
2. Use Up or Down buttons is used to adjust this value.
3. Depress the Extra Cycle button

```
VOLUME REMAINING
TANK: 0000000 9
```

Volume Remaining (System)

Volume remaining in the system cannot be edited when displayed in this mode, except for the Lead unit. It can only be viewed on the Lag unit.

1. Depress the Extra Cycle button

```
VOLUME REMAINING
SYS: 000000000 9
```

Valve Address

This diagnostic display is for 2 control valves or more in a system (a single valve will not display).

1. Depress the Extra Cycle button.

```
VALUE ADDRESS:
      # 2
```

Software Version

The electronic timer's software program version number will be displayed.

1. Depress the Extra Cycle button to exit.

```
VERSION: NXT
      1.00
```

NOTE: Diagnostic Mode programming will stop if the system goes into regeneration.

MX III CONTROLLER

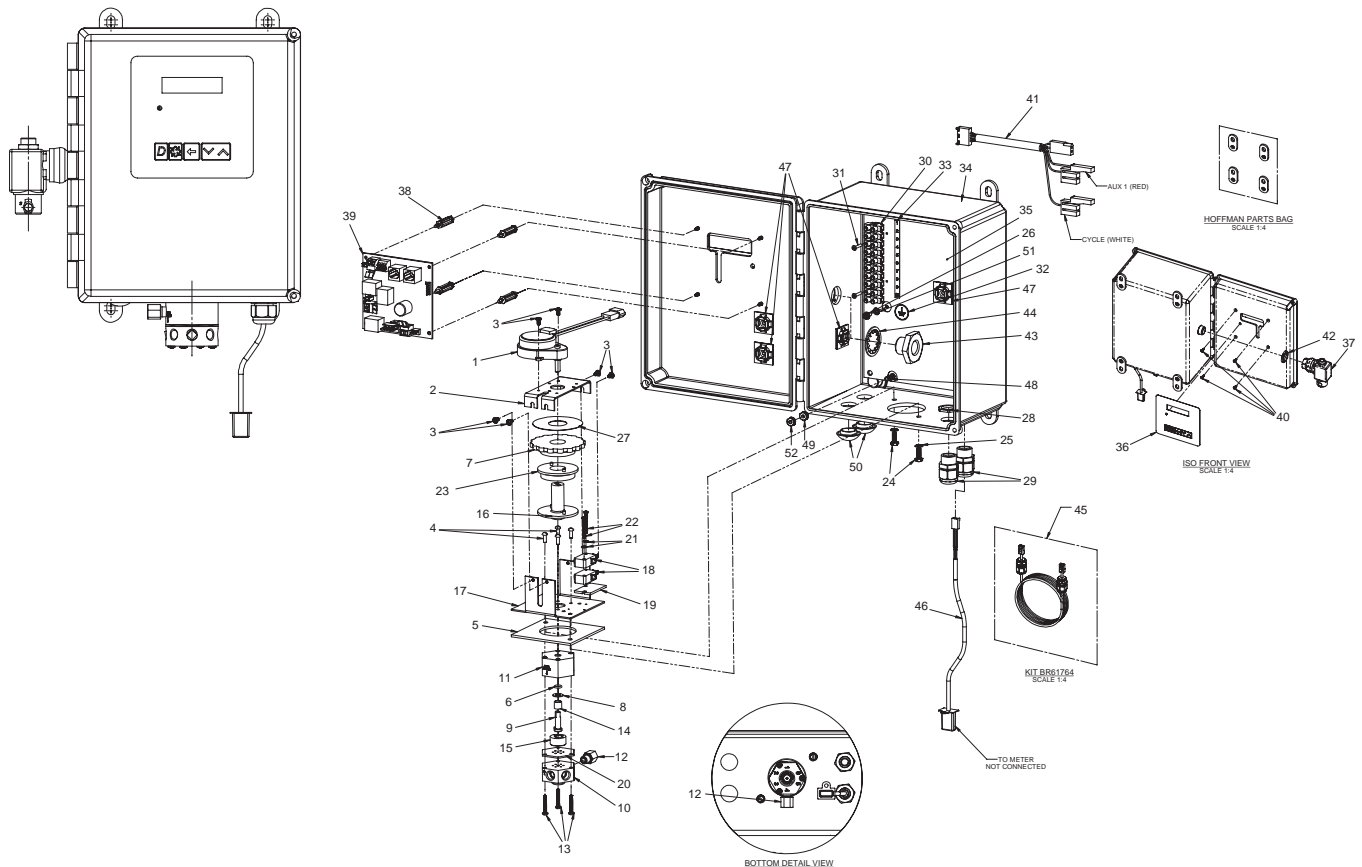

Item No.	QTY	Part No.	Description
1	1	43001	Motor, 24V, 50/60Hz, 5/8 RPM
2	1	1070436	Plate, Motor MTG, Stagers
3	6	1075746	Screw, 6-32 x 1/4", Phil
4	4	1072371	Screw, 6-32 x .375, RD.HD, SS
5	1	1075737	Gasket, Stager MTG, 48
6	1	1071667	O-ring, 2-010, Nitrile
7	1	1075454*	Thumb Wheel, Molded
8	1	1074074	Washer, 302, SS
9	1	1070448	Shaft, Stem Assy, 48 Series
10	1	1074784	Backplate, 48-00, Brass
11	1	1074793	Bonnet, 48, Brass
12	1	1074825	Inlet Strainer, Assy
13	3	1075759	Screw, Pan Head, 6-32 x .88"
14	1	1076234	Spring, Wave, 17-7 SS, 48 STGR
15	1	1074845	Stemplate, 48, -00
16	1	1076245*	Cam, Cycle, Machined
17	1	1070437	Plate, Bottom MTG, Stager
18	2	1075499	Switch, Micro
19	1	1075455	Switch Spacer, Insulator
20	1	1084171	Gasket, Backplate, 48 Nitrile
21	2	1073593	Washer, Lock, Internal, #4, SS
22	2	1075757	Machine Screw, 4-40 x 1.00, SS
23	1	1075453*	Cam, Auxiliary, Blank
24	2	3014200	Screw, Slotted HX HD, 10-32
25	2	1078992	Washer, Lock, Internal, #10, SS
26	1	14202-01	Screw, Hex Washer #8-32 x 5/16
27	1	43077-00	Label, Dial, STGR, 2 3/8 x 7/8
28	2	17967-01	Nut, Liquid Tight, HeyCo 3169
29	2	17967-02	Fitting, Liquid Tight, Black
30	1	1075538	Terminal Block, 10
31	2	1072369	Screw, Pan HD, 4-40 x 5/8, SS
32	1	1076219	Label, Ground, .75 Dia.
33	1	1073732	Label, Terminal Strip, 1-10

Item No.	QTY	Part No.	Description
34	1	43094-01	Enclosure, 48ES, NEMA 4
35	1	43093	Panel, A10P, 8" x 6" Modified
36	1	43046	Keypad Label Assy, XT, NEMA 4
37	1	1070649	Solenoid, N1, 24/60
38	4	42827-04	Stand-off, Plastic, .625"
39	1	42753U	Circuit Board, XT, ML
40	4	43092	Screw, FLT HD, #6-20, TYP-B
41	1	40941	Harness, Upper Drive
42	1	43090	Washer, Sealing, Conduit, 1/2"
43	1	43140	Fitting, NPT 1/2, Conduit
44	1	43141	Washer, Lock, 7/8, INT Tooth
45	1	61764	Cable Assy, COM, CAT 5E, NEMA 4
46	1	19121-09	Meter Cable Assy, NT, 99.5"
47	4	1081780	Mount, Cable Tie, 4-Way
48	1	1072379	Screw, 10-32 x 5/8", RND HD, SS
49	1	1071660	Nut, Hex, 10-32, KEPS
50	2	43138	Plug, .75, HeyCo
51	1	43177	Washer, Lock, #8, INT, 18-8 SS
52	1	1071648	Nut

Not Shown

1	61500-48/51LNE	Line Drawing
9	1073701	Tie, Cable, HeyCo VNT#4-18
2	1073702	Wire Tie
3	1073955	Terminal, Ring, #10, 16-14 GA
1	1073875	Wire, Black, 18 AWG
1	1073880	Wire, White, 18 AWG
1	1073874	Wire, Green, 14 AWG
1	41904-02	Programming, 3214NXT, 48ES
1	43147	Software, 3214NXT, America, V2.0
1	43163	Literature, 3214 NXT Stager,S/M
1	43012	Wiring Diagram, 48/51ES
1	61784	Service Kit, 48/51, Timer
1	61783	Service Kit, 48/51, Solenoid

REPLACEMENT VALVES

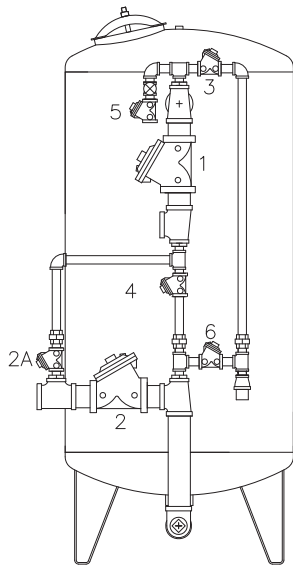

Location #	Function	Position
▲ 1	Service Inlet	Normally Open
■ 2	Service Outlet	Normally Open
2A	Bypass Valve Single System Only	Normally Closed
3	Backwash Outlet	Normally Open
■ 4	Backwash Inlet	Normally Open
5	Brine Inlet	Normally Open Spring Assist Open
6	Brine / Flush Outlet	Normally Open Spring Assist Open

NOTE: Valve 1 is Drilled and Tapped with 1/4" Female Thread on Boss #1
Valve 2 and 4 are Drilled and Tapped with 1/4" Female Thread on Boss #2

▲ Valve 1 is Drilled and Tapped with 1/4" Female Thread on Boss #1

■ Valve 2 and 4 are Drilled and Tapped with 1/4" Female Thread on Boss #2

Valve 2A - Is Used on Single Systems Only

MR Model	Pipe Size	Valve 1 ▲	Valve 2 ■	Valve 2A (single sys. only)	Valve 3	Valve 4 ■	Valve 5	Valve 6
150	1"	B2010102B	B2010202B	A2009001B	A2010001B	B2010201B	A2007001B	A2007001B
	1.25"	B2010103B	B2010203B	A2009001B	A2010001B	B2010201B	A2007001B	A2007001B
	1.5"	B2010104B	B2010204B	A2009001B	A2010001B	B2010201B	A2007001B	A2007001B
	2"	B2010105B	B2010205B	A2009001B	A2010001B	B2010201B	A2007001B	A2007001B
210	1.25"	B2010103B	B2010203B	A2009001B	A2010001B	B2010201B	A2007001B	A2007001B
	1.5"	B2010104B	B2010204B	A2009001B	A2010001B	B2010201B	A2007001B	A2007001B
	2"	B2010105B	B2010205B	A2009001B	A2010001B	B2010201B	A2007001B	A2007001B
	2.5"	B2010107B	B2010207B	A2009001B	A2010001B	B2010201B	A2007001B	A2007001B
300	1.5"	B2010104B	B2010204B	A2009001B	A2010001B	B2010201B	A2007001B	A2007001B
	2"	B2010105B	B2010205B	A2009001B	A2010001B	B2010201B	A2007001B	A2007001B
	2.5"	B2010107B	B2010207B	A2009001B	A2010001B	B2010201B	A2007001B	A2007001B
	3"	B2010108B	B2010208B	A2009001B	A2010001B	B2010201B	A2007001B	A2007001B
450	1.5"	B2010104B	B2010204B	A2009001B	A2010001B	B2010201B	A2007001B	A2007001B
	2"	B2010105B	B2010205B	A2009001B	A2010001B	B2010201B	A2007001B	A2007001B
	2.5"	B2010107B	B2010207B	A2009001B	A2010001B	B2010201B	A2007001B	A2007001B
	3"	B2010108B	B2010208B	A2009001B	A2010001B	B2010201B	A2007001B	A2007001B
600	1.5"	B2010104B	B2010204B	A2009002B	A2010002B	B2010202B	A2007002B	A2007002B
	2"	B2010105B	B2010205B	A2009002B	A2010002B	B2010202B	A2007002B	A2007002B
	2.5"	B2010107B	B2010207B	A2009002B	A2010002B	B2010202B	A2007002B	A2007002B
	3"	B2010108B	B2010208B	A2009002B	A2010002B	B2010202B	A2007002B	A2007002B
750	2"	B2010105B	B2010205B	A2009002B	A2010002B	B2010202B	A2007002B	A2007002B
	2.5"	B2010107B	B2010207B	A2009002B	A2010002B	B2010202B	A2007002B	A2007002B
	3"	B2010108B	B2010208B	A2009002B	A2010002B	B2010202B	A2007002B	A2007002B
900	2"	B2010105B	B2010205B	A2009002B	A2010003B	B2010203B	A2007002B	A2007003B
	2.5"	B2010107B	B2010207B	A2009002B	A2010003B	B2010203B	A2007002B	A2007003B
	3"	B2010108B	B2010208B	A2009002B	A2010003B	B2010203B	A2007002B	A2007003B
1050	2"	B2010105B	B2010205B	A2009002B	A2010003B	B2010203B	A2007002B	A2007003B
	2.5"	B2010107B	B2010207B	A2009002B	A2010003B	B2010203B	A2007002B	A2007003B
	3"	B2010108B	B2010208B	A2009002B	A2010003B	B2010203B	A2007002B	A2007003B

AQUAMATIC REPAIR KITS

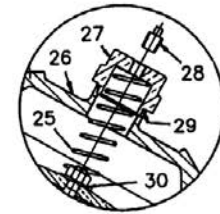
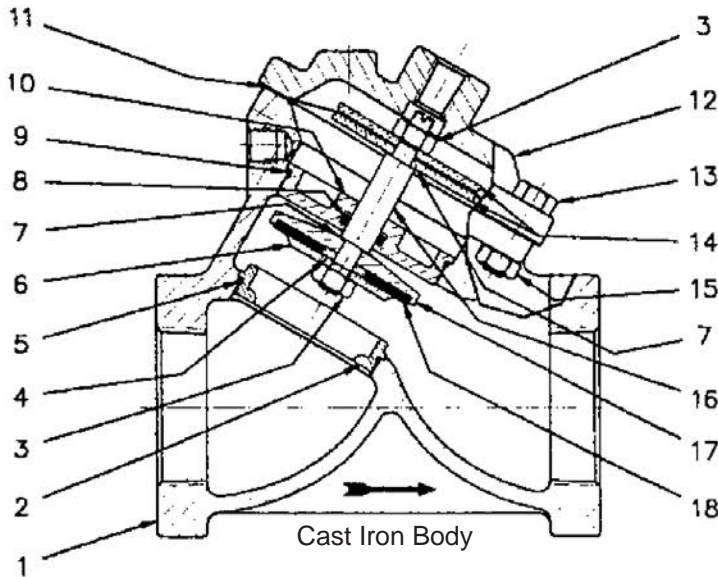

Spring Assist Closed

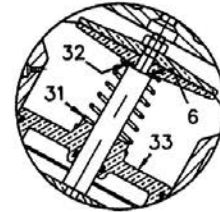

Spring Assist Open

- RA - Diaphragm & Seal Kits - Includes Buna N Seals and Diaphragm (Items 3(2),5,6,8(2),9,14&7)
- RF - Metal Parts Kit (Normally Open) - (Items 4,7,10,11(2), 17)
- RG - Metal Parts Kit (Normally Closed) - (Items 4,7,10,11(2), 23)
- SC - Repair Kit (Spring Assist Closed) - (Items 24,27,28)
- SO - Repair Kit (Spring Assist Open) - (Items 8,31,32)
- GT - Tool - To Install & Remove O-Ring Retainer (Not Shown)

Pipe Size	Valve Series	REPAIR KITS						SHAFTS (ITEM 16)	
		RA Type	RF Type	RG Type	SC Type	SO Type	GT Tool	Normally Open	Normally Closed
3/4"	421	A2089028	A2089071	A2089078	A2089085	A2089092	A2089098	A2137001	A2137008
1"	421	A2089028	A2089071	A2089078	A2089085	A2089092	A2089098	A2137001	A2137008
1-1/4"	424	A2089029	A2089072	A2089079	A2089086	A2089093	A2089098	A2137002	A2137009
1-1/2"	424	A2089029	A2089072	A2089079	A2089086	A2089093	A2089099	A2137002	A2137009
2"	425	A2089030	A2089073	A2089080	A2089087	A2089094	N/A	A2137003	A2137010
2-1/2"	426	A2089031	A2089074	A2089081	A2089088	A2089095	N/A	A2137004	A2137011
3"	427	A2089032	A2089075	A2089082	A2089089	A2089096	N/A	A2137005	A2137012
3 FLGD	427	A2089032	A2089075	A2089082	A2089089	A2089096	N/A	A2137005	A2137012
4 FLGD	428	A2089033	A2089076	A2089083	A2089090	A2089097	N/A	A2137006	A2137013
6 FLGD	429	A2089034	A2089077	A2089084	A2089091	N/A	N/A	A2137007	A2137014

2536 FLOW SENSOR AND FITTINGS

2536 GF SIGNET FLOW SENSOR

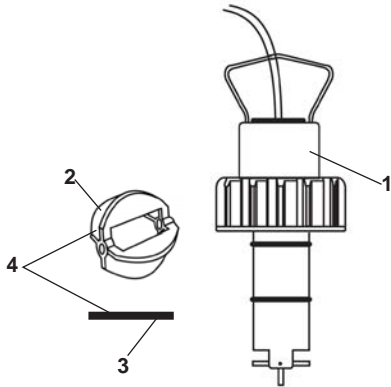

Item	Description	Part Number
1	Complete 2536 Flow Sensor	A2296001
2	Replacement Paddle / Rotor	A2456004
3	Pin	A2098027
4	Replacement Paddle Rotor & Pin	B1175025

K-FACTOR TABLE - SIGNET 2536
(Pulses per Gallon)

PIPE SIZE (inches)	GENERIC FLOW METER SETTINGS				
	MAX FLOW RATE (gpm)	TEE GALVANIZED	TEE PVC	SADDLE IRON	SADDLE PVC
1	49	213.01	352.44		
1-1/4	76	127.75	177.18		
1-1/2	110	94.40	117.85		
2	195	59.42	66.74	53.64	66.74
2-1/2	306			37.60	42.99
3	440			23.22	26.65
4	783			13.26	15.00
6	1762			11.04	8.32

2536 GF SIGNET FLOW SENSOR FITTINGS

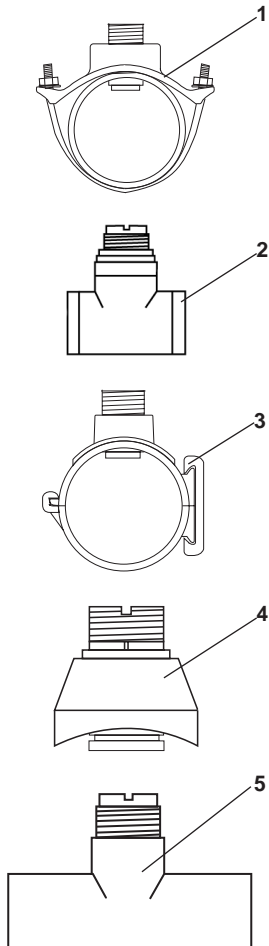

Item	Description	Part Number
1	2" Iron Strap-on Saddle	A2295014
	2-1/2" Iron Strap-on Saddle	A2295001
	3" Iron Strap-on Saddle	A2295002
	4" Iron Strap-on Saddle	A2295003
	6" Iron Strap-on Saddle	A2295005
2	1" Galvanized Iron Threaded Tee NPT	A2294012
	1-1/4" Galvanized Iron Threaded Tee NPT	A2294002
	1-1/2" Galvanized Iron Threaded Tee NPT	A2294003
	2" Galvanized Iron Threaded Tee NPT	A2294004
3	2" PVC Saddle	A2295026
	2-1/2" PVC Saddle	A2295009
	3" PVC Saddle	A2295010
	4" PVC Saddle	A2295011
	6" PVC Saddle	A2295012
4	2-1/2" Weldolet	A2579002
5	1" Copper Tee Sweat	A2569004
	1-1/2" Copper Tee Sweat	A2569009
	2" Copper Tee Sweat	A2294009

BRINE SYSTEM FOR MR 150M-450M

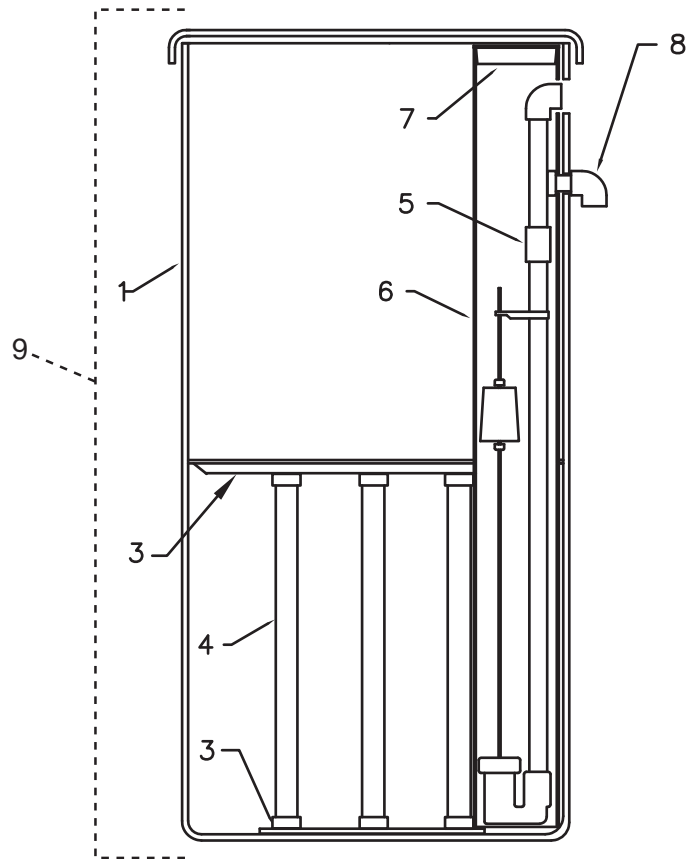

Item Number	Description	Part Number
1	BRINE TANK W/HOLES 24x50-MR 150-210	B1002007
	BRINE TANK W/HOLES 24x60-MR 300	B1002008
	BRINE TANK W/HOLES 39x60-MR 450	B1002009
3	GRID PLATE PLASTIC 24DIA 5"BW	A2284007
	GRID PLATE PLASTIC 30DIA 5"BW	A2284010
4	PIPE 1-1/2 SDR OR SCH40 DWV	A2275007
5	BRINE VALVE ASSEMBLY-MR 150	B1042001
	BRINE VALVE ASSEMBLY-MR 210	B1042002
	BRINE VALVE ASSEMBLY-MR 300-450	B1042003
6	BRINE WELL 5x46 DRILLED	B1015008
7	CAP PLUG RED 5 INCH	A2072001
8	ELBOW OVERFLOW 1/2" W/NUT	A2120002
9	COMPLETE BRINE TANK ASSEMBLY FOR MR 150M - 15"	B1039001
	COMPLETE BRINE TANK ASSEMBLY FOR MR 210M - 22"	B1039002
	COMPLETE BRINE TANK ASSEMBLY FOR MR 300M - 28"	B1039003
	COMPLETE BRINE TANK ASSEMBLY FOR MR 450M - 29"	B1039009

BRINE SYSTEM FOR MR 600M-1050M

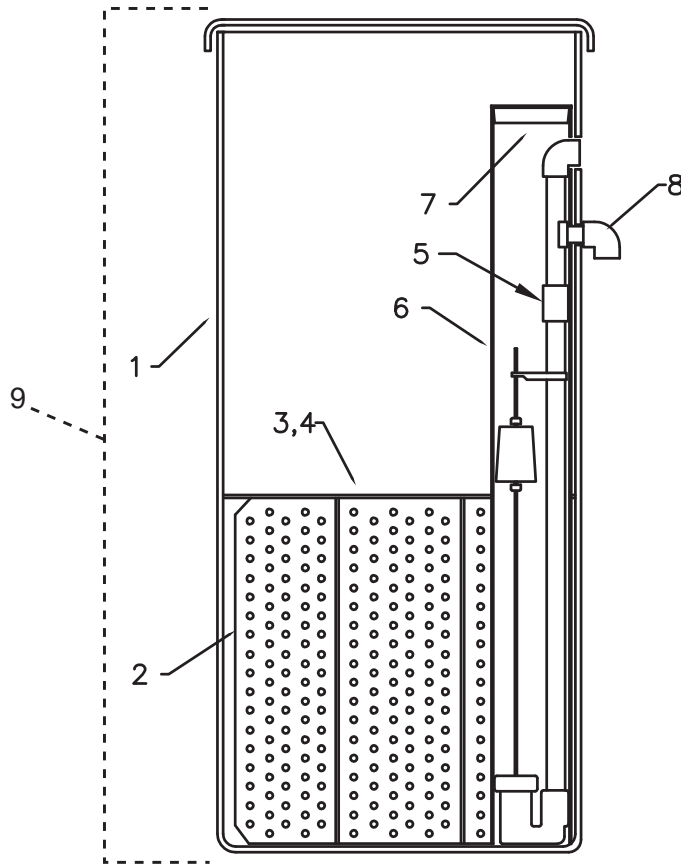

Item Number	Description	Part Number
1	BRINE TANK W/HOLES 39x60 – MR 600-750	B1002010
	BRINE TANK W/HOLES 42x60 – MR 900	B1002011
	BRINE TANK W/HOLES 50x60 – MR 1050	B1002012
2	GRID SUPPORT SET 39" DIA, 22" HT – MR 600-750	B1043010
	GRID SUPPORT SET 42" DIA, 29" HT – MR 900	B1043011
	GRID SUPPORT SET 50" DIA, 22" HT – MR 1050	B1043014
3	SALT SHELF 38-1/8" DIA – MR 600-750	B1041003
	SALT SHELF 41-1/4" DIA – MR 900	B1041004
	SALT SHELF 49" DIA – MR 1050	B1041005
4	SALT SCREEN 39" DIA. – MR 600-750	B1040003
	SALT SCREEN 42" DIA. – MR 900	B1040004
	SALT SCREEN 50" DIA. – MR 1050	B1040005
5	BRINE VALVE ASSY 22" GRID – MR 600,750,1050	B1042002
	BRINE VALVE ASSY 29" GRID – MR 900	B1042003
6	BRINE WELL 5x46 DRILLED	B1015008
7	ELBOW OVERFLOW 1/2" W/NUT	A2250003
8	CAP PLUG RED 5"	A2072001
9	COMPLETE BRINE TANK ASSEMBLY FOR MR 600M - 22"	B1039005
	COMPLETE BRINE TANK ASSEMBLY FOR MR 750M - 22"	B1039005
	COMPLETE BRINE TANK ASSEMBLY FOR MR 900M - 29"	B1039007
	COMPLETE BRINE TANK ASSEMBLY FOR MR 1050M - 22"	B1039008

ERROR CODES

If a communication error is detected, an Error Screen will alternate with the main (time of day) screen every few seconds.

- All units In Service remain in the In Service position.
- All units in Standby go to In Service.
- Any unit in Regeneration when the error occurs completes Regeneration and goes to In Service.
- No units are allowed to start a Regeneration Cycle while the error condition exists, unless they are manually forced into Regeneration.
- When an error is corrected and the error no longer displays (it may take several seconds for all of the units in a system to stop displaying the error message), the system returns to normal operation.

NOTE: During the error condition the control continues to monitor the flow meter and update the volume remaining. Once the error condition is corrected all units return to the operating status they were in prior to the error. Regeneration queue is rebuilt according to the normal system operation. Or, if more than one unit has been queued for regeneration, then the queue is rebuilt according to which one communicates first.

ERROR MESSAGE	CAUSE FOR ERROR	CORRECTION
Flashing Time	Power outage.	Program time by holding UP on Unit #1.
Detected Error = Matching Address	Two or more units programmed with the same valve address number	Program each unit with unique valve address number in Master Programming.
Detected Error = Program Mismatch	Master program parameters do not match between two or more controls.	Confirm Master Programming for each unit.
Detected Error = No Message #1	No power to Control #1.	Power Control #1..
	Communication Cable to Valve Address #1 bad or missing.	Connect or replace Communication Cable.
Detected Error = No Message #2	No power to Control #2.	Power Control #2.
	Communication Cable to Valve Address #2 bad or missing.	Connect or replace Communication Cable.
Detected Error = No Message #3	No power to Control #3.	Power Control #3
	Communication Cable to Valve Address #3 bad or missing.	Connect or replace Communication Cable.
Detected Error = No Message #4	No power to Control #4.	Power Control #4.
	Communication Cable to Valve Address #4 bad or missing.	Connect or replace Communication Cable.
Detected Error = E2 Reset Unit	This message appears after a software reset.	Reprogram control using Master Programming section.
Test Mode	Circuit Board was not programmed at factory.	Replace Circuit Board.
Black Squares on screen	Bad Circuit Board.	Replace Circuit Board.
INI on screen for more than 2 minutes	Circuit board not getting feedback from cycle switch.	Inspect Motor - should be rotating.
		Wire Harness disconnected.
		Check Cycle Micro Switch.
CHG on screen for more than 2 minutes	Control programmed incorrectly as 2900 or 3900 valve type.	Reprogram unit as Stager Valve type.

TROUBLESHOOTING

DETECTED ERRORS

NOTE: It can take up to 30 seconds for an error to be detected and displayed. All errors on each timer in the system must be displayed before the errors can be corrected.

If a communication error is detected, an Error Screen will alternate with the main (time of day) screen every few seconds.

- All units In Service remain in the In Service position.
- All units in Standby go to In Service.
- Any unit in Regeneration when the error occurs completes Regeneration and goes to In Service.
- No units are allowed to start a Regeneration Cycle while the error condition exists, unless they are manually forced into Regeneration.
- When an error is corrected and the error no longer displays (it may take several seconds for all of the units in a system to stop displaying the error message), the system returns to normal operation.

NOTE: During the error condition the control continues to monitor the flow meter and update the volume remaining. Once the error condition is corrected all units return to the operating status they were in prior to the error. Regeneration queue is rebuilt according to the normal system operation. Or, if more than one unit has been queued for regeneration, then the queue is rebuilt according to which one communicates first.

CAUSE	CORRECTION
A. One or more units have a missing or bad communication cable.	A. Connect the communication cables and/or replace.
B. One or more units has a communication cable plugged into the wrong receptacle.	B. Connect the communication cable as shown in the wiring diagrams.
C. One or more units is not powered.	C. Power all units.

PROGRAMMING ERRORS

During the error condition the control continues to monitor the flow meter and update the remaining capacity. Once the error condition is corrected all units return to the operating status they were in prior to the error and regeneration is queued according to the normal system operation. If reprogramming the unit in the Master Programming Mode clears the error, the volume remaining may be reset to the full unit capacity (i.e. as though it were just regenerated).

1. All units in standby go In Service.
2. Any unit in regeneration when the error occurs completes regeneration and goes to In Service.
3. No units are allowed to start a regeneration cycle while the error condition exists.

When the problem is corrected and the error no longer displays (it may take several seconds for all of the units in a system to stop displaying the error message), the system returns to normal operation.

Programming Errors Detected:

- Duplicate unit addresses or numbers
- Size of system (ex: if sized for a 4 units, and only have 2 units)
- Display format mismatches

Solution:

- Program the units correctly in the Master Programming Mode.

NOTE:

If these errors are detected, numbers 1 through 3 become true, and the main screen (time of day) will alternate with an error screen.

TROUBLESHOOTING CONTROLLER

CAUSE	CORRECTION
A. Any or all of two or more units programmed with the same unit number (Matching Address Error)	A. Connect the communication cables and/or replace.
B. Flashing/blinking display.	B. Power outage has occurred.
C. Format Mismatch (Units have both U.S. and Metric Formats)	C. Verify all units have same Format selected (all U.S. or all Metric)
D. No messages displayed/small black squares appear in display	D. Turn the contrast button on the back of unit until text appears (see “Problems Viewing Display/Changing Contrast of Display” below)
E. Size Error (Units not correctly numbered/more than one unit has the same number assigned)	E. Check each unit and verify each as the correct number, and that only one unit has that number
F. Com Error (Communication Error)	F. Check the wiring of the system and verify it is correct and that all are connected

EXAMPLE ERROR SCREENS

DETECTED ERROR=
E2 RESET UNIT

Detected Error

1. Go through Master Programming to program the unit.

DETECTED ERROR=
NO MESSAGE #1

No Message #1

1. Make sure all communication cables are connected.
2. If “No Message #1” ensure it is the lead unit.
3. Ensure #1 is configured for the correct system type.

DETECTED ERROR=
NO MESSAGE #3

No Message #3

1. Make sure all communication cables are connected.
2. If “No Message #3” ensure it is unit #3.
3. Ensure #3 is configured for the correct system type.

DETECTED ERROR=
PROGRAM MISMATCH

Program Mismatch

1. Ensure the units on the network are not configured the same as #1/the Lead unit.

DETECTED ERROR=
EXCEED UNIT SIZE

Exceed Unit Size

1. There are more units on the system than the Lead is programmed for.

DETECTED ERROR=
MATCHING ADDRESS

Matching Address

1. The unit is programmed the same # as another unit.

NOTE: The rest of the system will still function without this unit.

TROUBLESHOOTING SOFTENER

PROBLEM/SYMPTOM	PROCEDURE	POSSIBLE CAUSE
1. Slight leak to drain.	A. Disconnect tubing at backwash control	A. Flow indicates leaky seal in stager valve.
	B. If stager is not leaking, use soap test kit and check hardness of water at drain.	B. If water tests soft, Valve #6 is leaking: If water tests hard, Valve #3. See Problem 5
2. High flow to drain during service.	A. Check position dial.	A. If not in position #4, rotate stager clockwise to this position.
	B. If position dial is in #4, check for water leakage from Valve #3 or Valve #6 vent holes.	B. Leakage indicates: 1. Ruptured diaphragm 2. Loose diaphragm nut
	C. If vent hole is not leaking, use soap test kit and check hardness of water at drain.	C. If water tests soft, Valve #6 is open: If water tests hard, Valve #3. See Problem 5
3. Failure to draw brine.	A. Check that manual brine valve is open wide.	A. Valve must be open at all times, except when servicing.
	B. Check water pressure.	B. Water pressure must be a least 30 psi during regeneration.
	C. Turn position dial clockwise to position #2. Break union in suction line to injector and feel for suction.	C. If there is suction, automatic brine valve may be clogged. No suction indicates: 1. Drain pipe to small or discharging at level too high above floor. 2. Plugged pilot strainer. 3. Plugged injection nozzle. 4. Valves #1, #4, or #2 not closing fully. See Problem #5 5. Plugged backwash controller. 6. Dirty mineral bed.
4. Slight leak from vent hole.	A. Turn position dial clockwise to a position, which relieves pressure on valve.	A. If leaking stops, there is possibly a loose diaphragm nut, a small Tear in diaphragm, or the washer under diaphragm is missing. If leaking does not stop, shaft guide O-ring is damaged, shaft guide is not seated against gasket, or shaft is damaged.
5. Diaphragm valve does not close or seat completely.	A. Check that vent hole is not plugged.	A. If vent hole is plugged, air in space between diaphragm and shaft guide will compress and prevent valve from closing.
	B. Check for water leak at vent hole.	B. See Problem #4
	C. Loosen tubing nut at diaphragm cap.	C. If there is no flow, pilot strainer may be plugged.
	D. Turn off water pressure and disassemble diaphragm valve.	D. Seat washer may be dirty, worn or loose. Seat may be eroded.
6. Diaphragm valve does not open.	A. Check that vent hole is not plugged.	A. If vent hole is plugged, a partial vacuum will be created in the space between the diaphragm and shaft guide, preventing valve from opening.
	B. Loosen tubing nut at diaphragm cap.	B. Check for flow 1. If there is flow, stager valve is leaking. 2. If there is no flow, tubing fitting may be plugged.

TROUBLESHOOTING SOFTENER

PROBLEM/SYMPTOM	PROCEDURE	POSSIBLE CAUSE
7. Hard water leakage into service lines.	A. Close inlet and outlet valves and inspect by-pass valve.	A. Examine valve <ol style="list-style-type: none"> 1. Seat washer may be loose or worn. 2. Seat may be rough. 3. Shaft orifice plugged. 4. Diaphragm ruptured.
	B. Check that Valve #4 is seating.	B. See Problem 5.
8. Restricted or no drain flow during backwash.	A. Either Valve#1 or Valve#2 is not opening fully. To determine which one: Turn position dial to position #1 and then to position #3. Compare flow at drain.	A. Flow should be the same for both positions. <ol style="list-style-type: none"> 1. If no difference is noted, valve #4 is not opening properly. 2. If backwash flow is higher, valve #1 is not opening properly. See problem #7.
	B. Turn position dial to position #1 and then position #3. Compare flow at drain.	B. Flow should be the same. If flow for position also is low. <ol style="list-style-type: none"> 1. Inlet water pressure may be low. 2. Backwash flow control may be plugged. 3. If position #3 flow rate is higher, either valve #4 or valve #3 is not opening. See problem #7.
9. Loss of softening resin (evidence of resin in drain lines).	A. Open vent in top of softener tank and check for air in tank.	A. If air is present <ol style="list-style-type: none"> 1. Vent completely and recheck prior to next regeneration. 2. If recheck discloses a recurring build-up of air, check brine system(s) for possible leaks in suction line or brine valve not seating properly. 3. If brine system is functioning properly source of air may be in the water supply to unit. Use of an automatic air relief valve is indicated in this situation (consult factory for recommendation).
	B. Check automatic backwash control valve for rate of flow in excess of listed flow (gpm)	B. Check for excessive inlet water supply pressures– reduce to rated pressure.
10. Loss of softening resin (evidence of resin and/or gravel in service lines).	A. Check for damage to softener under-drain system.	A. Investigation of damage to under-drain generally requires unloading of softener tank. Consult factory for recommended procedures before proceeding.

NOTES

NOTES



2227 South Street • P.O. Box 044170 • Racine, WI 53404-7003 • www.Marlo-Inc.com