



“KLEAR FLO II” AUTOMATIC WATER CONDITIONERS



INSTALLATION, OPERATION, AND MAINTENANCE MANUAL

FILL IN FOR FUTURE REFERENCE

MODEL NO: _____

SERIAL NO: _____

DATE INSTALLED: _____

DEALER: _____

TABLE OF CONTENTS

Installation Diagram.....	1
Installation Instructions	2
Start-Up Procedures	3
Principle of Operation.....	5
Recharge Sequence.....	6
System Component Parts List.....	7
MCV Valve Assembly	8
Injector, Refill Port, & Drain Assembly for Oxidizer Vessel.....	10
Injector, Refill Port, & Drain Assembly for Filter Vessel	13
Water Meter & Meter Plug	14
Bypass Valve.....	15
Valve Fittings	16

Klear Flo II Installation Diagram

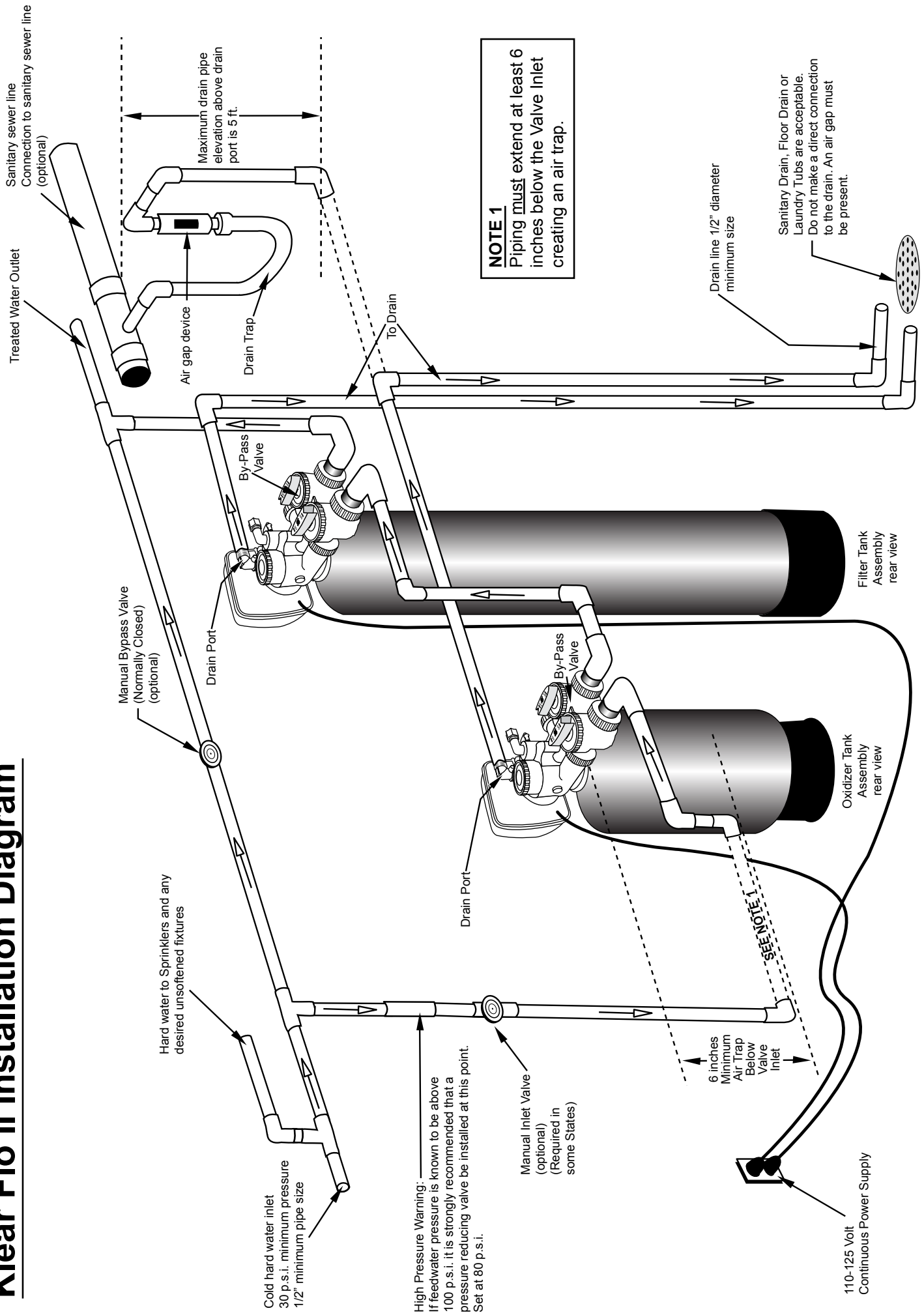

INSTALLATION INSTRUCTIONS

Proper operation of this equipment is dependent on an installation that conforms to the manufacturers instructions and follows local plumbing and electrical codes. Meeting the following requirements will assure long, reliable product operation.

INSTALLATION REQUIREMENTS

- Select a heated installation location that has sufficient floor space and headroom to provide access for ease of installation and servicing. Refer to the Specification Table for dimensional data. Ambient temperature must never drop below 40 degrees F. to protect from freezing. Maximum water temperature + 110 Degrees F.
- Locate Filter System piping as close as possible to the source of the building water supply. The ideal location is after the pressure tank and all outside water taps and prior to an existing water softener. Never install between the water pump and pressure tank or on an intermittent water pressure source.

NOTE: This system is not designed for irrigation purposes.

- A grounded uninterrupted electrical power source (115 volts, 60 Hertz, 1 Ampere) is required to operate the fully automatic controls.
- An adequately sized floor drain, dry well or sump pit is required to collect wastewater during recharge of the Filter System. Refer to Specification Table for Backwash flow rate. The wastewater is harmless but can stain surfaces it comes in contact with.
- The Control Valve, Bypass and installation fittings are designed to accommodate minor plumbing misalignments. Components are not designed to support the weight of the Filter Vessel or the plumbing system.
- Soldering of plumbing fittings must be performed away from plastic valve components.

SYSTEM COMPONENTS

The Filter System is shipped in multiple cartons. Prior to starting installation, verify that all required components are available.

- One (1) Oxidizer Filter Vessel 16" x 28" (Tank #1), with riser pipe, fill-port plug, plastic cap and control valve.
- One (1) Filter Vessel (Tank #2), with riser pipe, plastic cap and control valve.
- One (1) Bag gravel, 50 Lb. - Labeled L1 for Tank #1.
- One (1) Bag Calcite, 100 Lb. - Labeled L2 for Tank #1.
- One (1) Bag Plastic Baffles, 500 pieces - Labeled L3 for Tank #1.
- One (1) Bag gravel, 20 Lb. - Labeled L1 for Tank #2.
- One (1) Bag coarse garnet, 20 Lb. - Labeled L2 for Tank #2.
- One (1) Bag fine garnet, 32 Lb. - Labeled L3 for Tank # 2.
- One (1) Bag Greensand, 70 Lb. - Labeled L4 for Tank #2.
- One (1) Bag Anthracite, 12 Lb. - Labeled L5 for Tank #2.
- One (1) Funnel.
- One (1) Instruction Manual.

CAUTION: The two Control Valves provided for these systems are different and must not be interchanged. The Control Valve used on the Oxidizer Vessel (Tank #1) is easily identified by having an Air Inlet Screen. Air Inlet Screen is shown on page 12 of this manual.

OXIDIZER VESSEL PREPARATION

1. Remove Oxidizer Filter Vessel from shipping carton. Carefully unscrew the Control Valve mounted on top of the Tank Set the Valve aside. The Riser Pipe in the Oxidizer Vessel should be 1" above the top of the tank.
2. Place Oxidizer Vessel (Tank #1) at installation location.
3. Plug distributor tube so that no media enters the distributor tube.
4. Pour gravel from bag labeled L1 for Tank #1 into Oxidizer Vessel. A funnel is provided for convenience.
5. Pour Calcite from bag labeled L2 for Tank #1 into Oxidizer Vessel. Remove funnel.
6. Place Plastic Baffles from bag labeled L3 for Tank #1 into Oxidizer Vessel.
7. Wipe dust from threads of Tank Adapter and Riser Pipe. Remove the plastic cap from Riser Pipe opening.
8. Lubricate both O-Rings on the base of the Oxidizer Control Valve. Install the Oxidizer Control Valve into the Mineral Tank Adapter threads turning clockwise until the control valve is tight.



FILTER VESSEL PREPARATION

1. Remove Filter Vessel from shipping carton. Carefully unscrew the Control Valve mounted on top of the Tank. Set the Valve aside. The Riser Pipe in Filter Vessel should be 1" above the top of the Vessel.
2. Place Filter Vessel (Tank #2) at installation location. Temporarily install plastic cap onto top of Riser Pipe.
3. Pour gravel from bag labeled L1 for Tank #2 into Filter Vessel. A funnel is provided for convenience.
4. Pour coarse Garnet from bag labeled L2 for Tank #2 into the Filter Vessel.
5. Pour fine Garnet from bag labeled L3 for Tank #2 into the Filter Vessel.
6. Pour Greensand from bag labeled L4 for Tank #2 into the Filter Vessel.
7. Pour Anthracite from bag labeled L5 for Tank #2 into the Filter Vessel. Remove funnel.
8. Wipe dust from threads of Tank and Riser Pipe. Remove the plastic cap from Riser Pipe opening.
9. Lubricate both O-Rings on the base of the Filter Control Valve. Install the Filter Control Valve into the Tank threads by turning clockwise until the control valve is tight.

PLUMBING CONNECTIONS

Both Control Valves are equipped with a By-Pass Valve eliminating the need for manual isolation valves.

1. Select a point in the building plumbing after irrigation branches and before an existing water softener. Connect the Inlet port of the Oxidizer Vessel Valve to the pressurized water source at that point (see diagram on page 1 of this manual).
2. Connect the Outlet port of the Oxidizer Valve to the Inlet port of the Filter Valve.
3. Connect the Outlet port of the Filter Valve to the treated water piping of the building.
4. Both Valves require a connection to drain. Local plumbing codes will require an air gap to prevent sewage backup into the Filter System. Rigid tubing or pipe is recommended. **IMPORTANT:** Pressurized air and water is released during recharge. The end of the drain piping **must be secured** and positioned to prevent movement and splashing. Drain lines should not exceed 5 ft. above the top of the valve or 25 ft. in length.

IMPORTANT: Do not apply water pressure to the Filter System at this time. Position the handles on both By-Pass Valves to the By-Pass positions (arrows should be pointing at each other).

ELECTRICAL CONNECTIONS

1. Both Valves require connection to a continuous source of electrical power. **Do not** plug in control valves in at this time!
2. Filter System installations into metallic plumbing (copper tubing or galvanized pipe) requires a grounding strap. Connect length of 12 Gauge wire between the inlet pipe of the Oxidizer Valve and the outlet pipe of the Filter Valve. Strap the bared ends of the copper wire to the cleaned outside surface of the metal pipe. Route the wire carefully to prevent breakage. Installations into plastic plumbing do not require the grounding strap.

START-UP PROCEDURES

NOTE: DO NOT PLUG THE CONTROL VALVES INTO AN ELECTRICAL OUTLET UNTIL INSTRUCTED TO DO SO.

1. Make sure both units are in the bypass position.
2. Close all valves that are open.
3. If you have a water softener installed make sure it is bypassed.
4. Turn on the main water supply. Turn water on at the closest cold water tap. Allow water to run until all excess air has been relieved and water runs clear.
5. Close faucet.

OXIDIZER START-UP

6. Open the inlet valve a 1/4 turn to allow water to enter the oxidizing filter. The control valve is shipped in the Fast Rinse cycle. This allows water to run to the drain. Once water is running to the drain slowly, open the inlet completely.
7. Let water run to drain for 10 minutes or until water runs clear.
8. Remove cover and plug the four prong adaptor into the circuit board. Replace cover for the oxidation tank.
9. Plug the transformer for the oxidation tank into a 120V electrical outlet and allow control to cycle to the Home position.
10. Open outlet valve and slowly open inlet valve on filtration tank.
11. Allow filtration tank to fill with water.
12. Open outlet valve on filtration tank.
13. Open a treated water faucet and allow excess air to escape. When water runs clear, turn faucet off.
14. Do not initiate a regeneration.
15. Plug filtration unit into a wall receptacle.
16. Do not initiate a regeneration.



17. The unit must sit for 24 to 48 hours before a complete regeneration should occur. This gives the media time to saturate. Insufficient saturation time will cause media to be lost to drain. **FAILURE TO FOLLOW PROPER START-UP INSTRUCTIONS WILL RESULT IN EQUIPMENT MALFUNCTION NOT COVERED UNDER WARRANTY.**
20. Open the nearest cold water faucet.
21. Allow water to run until clear and excess air has been purged from the line.
22. Close faucet.
23. If you have placed the water softener in bypass, return the softener to the Service position.
24. Open shut off valve to the water heater.
25. Verify the regeneration times. See step 1 below.
26. Set time of day. See page 5 & 6.

BACKWASHING

The Filter Vessel (Tank #2) must independently Backwash prior to the Oxidizer Vessel (Tank #1). It is important to stagger the Backwash start time for each Vessel. If there is a water softener system present, it is important to not only schedule staggered backwashing times of the filters, but also at different times than the softener's scheduled backwashing time. The Klear-Flo II units are preset to have staggered backwash times. These backwash times are recommended because most water residential water supplies do not produce sufficient flow and pressure to backwash both Vessels simultaneously.

1. **FILTER VESSEL SETTINGS** - Follow the procedure below to set the filter vessel regeneration time & frequency.
 - A. On the filter vessel, press the NEXT and UP arrow keys simultaneously for three to five seconds. The screen will show -nA-. Press the NEXT key.
 - B. The filter comes pre-programmed for 3 days. Changes can be made later if different backwash cycle intervals are required.
 - C. Once days between regeneration has been selected press the NEXT key.
 - D. Time of Regeneration screen. The unit comes preset at 1 AM. To change the time, use the UP or DOWN arrow keys. Make sure to note AM or PM. Press NEXT to set minutes. Press NEXT to return to home screen.
2. **OXIDIZER VESSEL SETTINGS** - Follow the procedure below to set the oxidizer vessel:
 - A. On the oxidizer vessel, press the NEXT and UP arrow keys simultaneously for three to five seconds. The screen will show -nA-. Press the NEXT key.
 - B. Set the **Days to Regenerate**. The Oxidizer Vessel is capable of treating 1,000 gallons per regeneration. Daily water usage will determine the regeneration frequency. Select one recommended regeneration schedule from the following table:
 - Recharge every 3 days - (1-2 people per family or 200 gallon/day water usage)
 - Recharge every 2 days - (3-4 people per family or 400 gallon/day water usage)
 - Recharge every day - (5 or more people per family or 1000 gallon/day water usage.)Changes can be made later if different Backwash cycle intervals are required.
 - C. Once days between regeneration has been selected press the NEXT key.
 - D. Time of Regeneration screen. The unit comes preset at 12 AM. To change the time, use the UP or DOWN arrow keys. Make sure to note AM or PM. Press NEXT to set minutes. Press NEXT to return to home screen.

IMPORTANT: UNITS ARE PRE-PROGRAMMED TO HAVE STAGGERED BACKWASH TIMES. IF YOU CHOOSE TO RE-PROGRAM, PLEASE REMEMBER TO SET STAGGERED BACKWASH TIMES.

WATER SOFTENER NOTE: The Klear-Flo Filter System is compatible with most automatic Water Softeners. The Softener will perform best when installed **after** the Klear-Flo Filter System. The regeneration schedule of the water softener must be set to start **3 hours before or 2 hours after** the Klear-Flo start time. This will assure that sufficient water volume and drain capacity is available for the regeneration process of each unit.

User Display Settings

When the system is operating, several displays may be shown. Pressing NEXT will alternate between the displays. One of the displays is the current time of day. CAPACITY REMAINING is the gallons that will be treated before the system goes through a regeneration cycle. Pressing DOWN while in the Capacity Remaining display will decrease the capacity remaining in 10 gallon increments and will also increase the volume used impacting the recorded values in Diagnostics.

DAYS TO A REGEN is the number of days left before the system goes through a regeneration cycle. Pressing UP or DOWN while in this screen will temporarily increase or decrease the displayed value by 1 day. Another display shows the current treated water flow rate through the system. Contact information will be displayed if it was edited.

The fifth display will show either DP or HOLD if the dP switch is closed. If the system has called for a regeneration that will occur at the pre-set time of regeneration, the words REGEN TODAY will alternate with the header on the display. If a water meter is installed, GPM flashes (and alternates with the flow rate) on the display when water is being treated (i.e. water is flowing through the system).

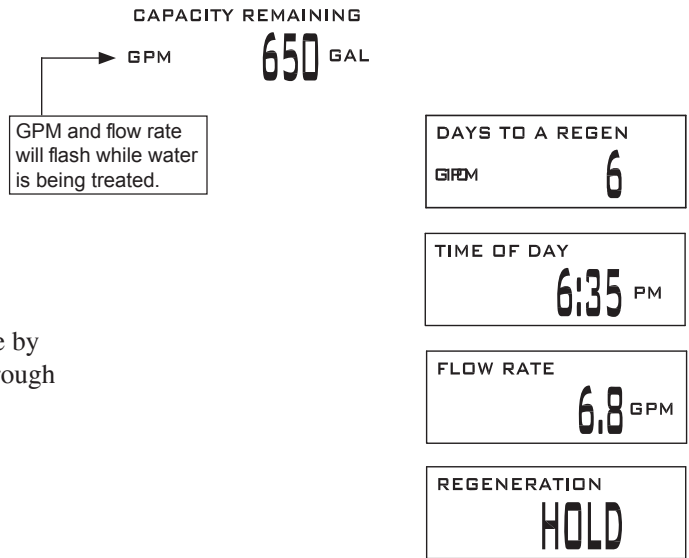

Regeneration Mode

Typically a system is set to regenerate at a time of low water usage. An example of a time with low water usage is when a household is asleep. If there is a demand for water when the system is regenerating, untreated water will be used.



When the system begins to regenerate, the display will change to include information about the step of the regeneration process and the time remaining for that step to be completed. The system runs through the steps automatically and will reset itself to provide treated water when the regeneration has been completed.

Manual Regeneration

Sometimes there is a need to regenerate the system sooner than when the system calls for it, usually referred to as manual regeneration. There may be a period of heavy water usage because of guests or a heavy laundry day.

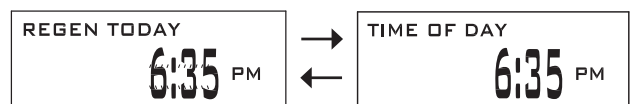

To initiate a manual regeneration at the preset delayed regeneration time, when the regeneration time option is set to “DELAYED REGEN” or “DELAY + IMMEDIATE”, press and release “REGEN”. The words “REGEN TODAY” will periodically be shown on the display to indicate that the system will regenerate at the preset delayed regeneration time. If you pressed the “REGEN” button in error, pressing the button again will cancel the request. Note: If the regeneration time option is set to “IMMEDIATE” there is no set delayed regeneration time so “REGEN TODAY” will not activate if “REGEN” button is pressed.

To initiate a manual regeneration immediately, press and hold the “REGEN” button for three seconds. The system will begin to regenerate immediately. The request cannot be cancelled.

Note: For softeners, if brine tank does not contain salt, Fill with salt and wait at least two hours before regenerating.

Set Time of Day

The user can also set the time of day. Time of day should only need to be set if the battery has been depleted because of extended power outages or when daylight saving time begins or ends. If an extended power outage occurs, the time of day will flash on and off which indicates the time of day should be reset. The non rechargeable battery should also be replaced.

STEP 1U

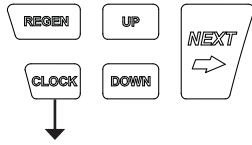

STEP 1U – Press CLOCK.

STEP 2U

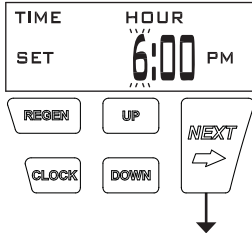

STEP 2U - Current Time (hour): Set the hour of the day using DOWN or UP. AM/PM toggles after 12. Press NEXT to go to Step 3U.

STEP 3U

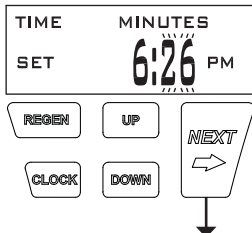

STEP 3U - Current Time (minutes): Set the minutes of the day using DOWN or UP. Press NEXT to exit Set Time of Day. Press REGEN to return to previous step.

RETURN TO NORMAL MODE

PRINCIPLE OF OPERATION

The Klear-Flo II uses a four-step process called Oxidation/Filtration to reduce the levels of iron, manganese and hydrogen sulfide gas from potable water without the need for retention tanks, chemicals, air compressors and re-pressurizing pumps. The system is comprised of two vessels and controls connected in series. The first being the Oxidizer Vessel and the second being the Filter Vessel. The Oxidation/Filtration process modifies the characteristics of the water flowing through the vessels. The individual steps are described in their order of occurrence:

1. Oxygen Enrichment - Flowing water and air are combined under pressure. The flowing water takes on a higher concentration of air similar to carbonating a beverage. This step occurs in the top of the Oxidizer Vessel.
2. Acidity Reduction - The corrosive effects of aggressive water is reduced. As a result, metallic components of the plumbing system will be protected from corrosion. The reduced acidity also promotes a rapid reaction between the oxygen introduced in Step # 1 and flowing water to promote Precipitation. This step occurs in the bottom of the Oxidizer Vessel.
3. Precipitation - The oxygen component of the air reacts with dissolved compounds of iron, manganese and sulfide in the flowing water. The oxygen safely breaks the dissolved compounds down into a harmless particulate state that is readily removed by Filtration. This step occurs in the top of the Filter Vessel.
4. Filtration - Particles (oxides) of iron, manganese and sulfides are removed from flowing water. Multiple layers of granular media trap the oxides passing only clear, odorless, stain free water. This step occurs in the bottom of the Filter Vessel.

The Oxidation/Filtration process silently treats water on demand over a wide range of flows. During operation, the compressed air charge in the Oxidizer Vessel enriches the water with air containing Oxygen. The Oxygen provides the chemical energy needed to produce iron, manganese and sulfur oxides. The newly formed precipitated oxides are trapped in the Filter Vessel as water is treated. The treated water exits the filter with an excess of dissolved air causing a cloudy (milky) appearance when first dispensed. Upon standing the water clears as the excess air escapes.

Eventually the compressed air charge depletes and the Oxidizer Filter is filled to capacity with oxides. A charge sequence is required to both replenish the air and remove the filtered oxides. The system is fully automatic and self recharges on an adjustable, programmed time schedule. The amount of filtered water delivered is dependent on the amount of contaminants in the water and the frequency of recharges.



RECHARGE SEQUENCE

The Klear-Flo II filter system is comprised of two individual pressure vessels each having plumbing connections providing a means for installation into a continuously pressurized water system. The vessels are installed in series with the Oxidizer Vessel positioned ahead of the Filter Vessel. A demand for treated water causes flow to occur through both vessels. Raw water entering the filter is first oxygenated then filtered. This cycle of operation is referred to as SERVICE. Eventually the filter system requires a recharge of oxygen and a thorough cleaning of the filtration media. This multi step process is referred to as the RECHARGE SEQUENCE.

Each vessel is individually recharged in succession during a time period when treated water demand is low. The recommended times for recharge are AM for the Oxidizer Vessel and AM for the Filter Vessel. The time intervals must be staggered so each vessel has access to an adequate water supply. Each vessel is equipped with an adjustable calendar clock controller capable of initiating the recharge sequence at a user-determined schedule. (Refer to Determining a Recharge Schedule) The following is a description of each step in the RECHARGE SEQUENCE.

The Oxidizer Vessel is sequenced first (Steps # 1 - 4) followed by the Filter Vessel (Steps # 5 - 7). Water pressure and flow is available during all steps of the RECHARGE SEQUENCE, however the water quality may be unsatisfactory during this time interval.

1. **FLUSH #1** - Raw water is by-passed directly to the Filter Vessel. The Oxidizer Vessel is repressurized with water compressing the new air charge. The down flow of water is directed to the bottom of the vessel and discharged to drain. The compressed air remains at the top of the Vessel.
2. **BACKWASH #1** - Raw water is by-passed directly to the Filter Vessel and is also directed into the bottom of the Oxidizer Vessel. The top of the Oxidizer Vessel is vented to atmosphere and routed to a drain. The remaining air charge is released. Simultaneously the trapped particles in the pH neutralizing granular filter media are removed by a reverse flow of water and discharged to the drain.
3. **AIR INJECTION** - Raw water is by-passed directly to the Filter Vessel. All water is removed from the Oxidizer Vessel and replaced with a fresh supply of air at atmospheric pressure. This process is accomplished with a venturi. There will be a low flow of water to the drain.
4. **OXIDIZER RETURN TO SERVICE** - Oxygenated, pH neutral, filtered water is available for the recharge of the Filter Vessel. There will not be a flow to the drain.
5. **BACKWASH #2** - Oxygenated, pH neutral, partially filtered water is by-passed directly to the Filter outlet and is also directed into the bottom of the Filter Vessel. The top of the Filter Vessel is vented to atmosphere and routed to a drain. Trapped particles in the granular filter media are removed by a reverse flow of water and discharged to the drain.
6. **FLUSH #2** - Oxygenated, pH neutral, partially filtered water is by-passed directly to the Filter outlet. The down flow of water is directed to the bottom of the vessel and discharged to drain. Remaining particles are flushed from both Vessels.
7. **SYSTEM RETURN TO SERVICE** - Oxygenated, pH neutral, odor free, filtered water is available at the Filter System outlet. There will not be a flow to the drain.



KLEAR FLO II SYSTEM COMPONENT PARTS LIST

FILTER VESSEL

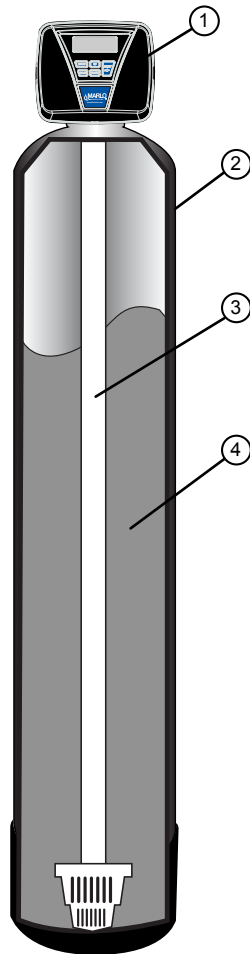

OXIDIZER VESSEL

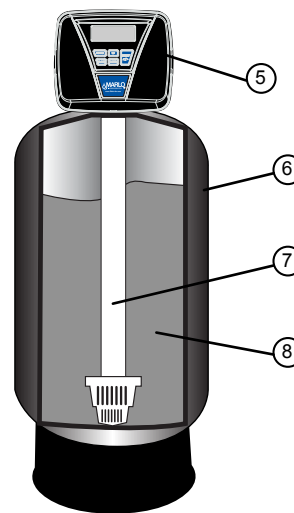

Item No.	Part No.	Description
1	B1074162	Control Valve - Filter
2	A2126207	Media Tank - Filter
3	B1023056	Distributor Tube Assembly - Filter
4	B1228070	Media Pack - Filter
5	B1074166	Control Valve - Oxidizer
6	A2126125	Media Tank - Oxidizer
7	B1023058	Distributor Tube Assembly - Oxidizer
8	B1228081	Media Pack - Oxidizer
not shown	B1228068	Media Pack Complete - Both Oxidizer & Filter Media

**Drive Cap Assembly, Downflow Piston,
Regenerant Piston and Spacer Stack Assembly
& Front Cover and Drive Assembly**



Lift tab to remove item 10

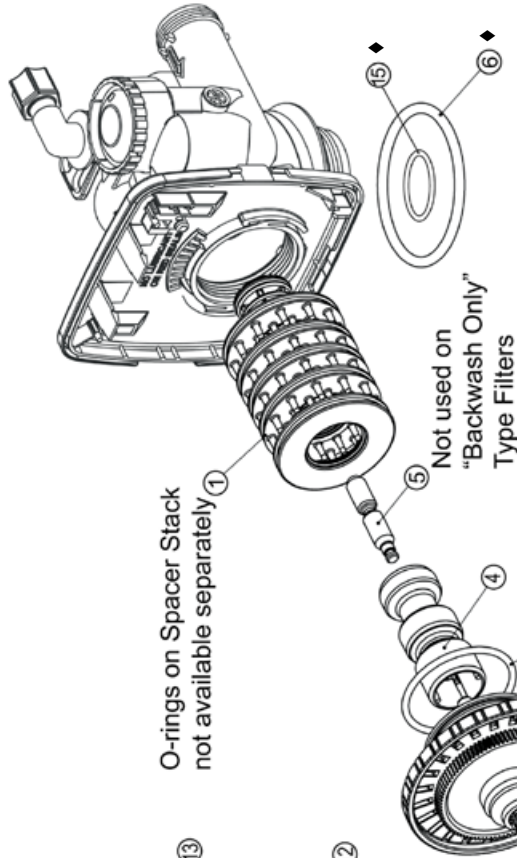

O-rings on Spacer Stack not available separately ①

Not used on "Backwash Only" Type Filters

Turn counter-clockwise to remove.
Turn clockwise to install.

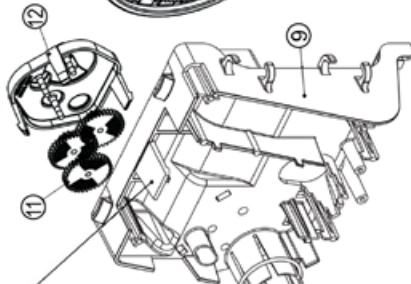

When replacing the battery, align positives and push down to fully seat.

Battery Fully Seated

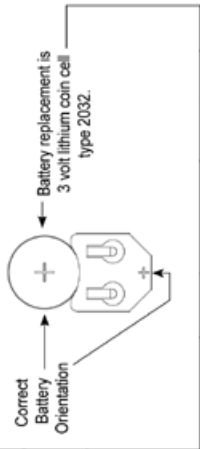

Correct Battery Orientation
Battery replacement is 3 volt lithium coin cell type 2032.

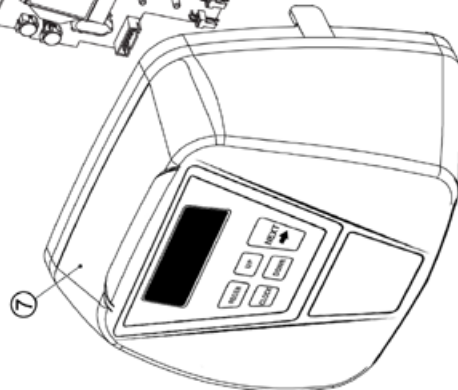
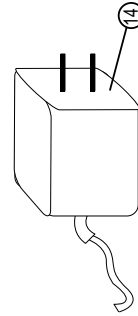

Drive Cap Assembly, Downflow Piston, Upflow Piston, Regenerant Piston and Spacer Stack Assembly

Item No.	Part No.	Description	Quantity
1	A2466034	*Spacer Stack Assembly w/o o-rings	1
2	A2080077	Drive Cap Assembly	1
3	B1213022	O-Ring 228 (use Valve O-ring Kit)	1
▲ 4	A2309040	Piston Downflow Assembly	1
⊗ 5	A2438033	Regenerant Piston	1
6	B1213022	O-Ring 337 (use Valve O-ring Kit)	1
15	B1213022	O-Ring 215 (use Valve O-ring Kit)	1

▲ Item #4 identified with “DN” code.

⊗ Item #5 not used with Backwash Only filter applications.

Front Cover and Drive Assembly

Item No.	Part No.	Description	Quantity
7	A2103160	Front Cover ASSY V3948-01	1
8	A2085050	Motor	1
9	A2328046	Drive Bracket & Spring Clip	1
10	A2341033	PC Board V3955MA-BOARD	1
11	A2393046	Drive Gear 12 x 36	3
12	A2103132	Drive Gear Cover	1
13	A2491086	Service Tool	1
14	A2242054	Transformer 110V - 12V	1

OXIDIZER UNIT

**Injector Cap, Injector Screen, Injector, Plug ,
O-Ring, Refill and Refill Port Plug,
& Drain Line - 3/4"**

◆ Part of Kit, O-ring (Item #51, pg. 20)

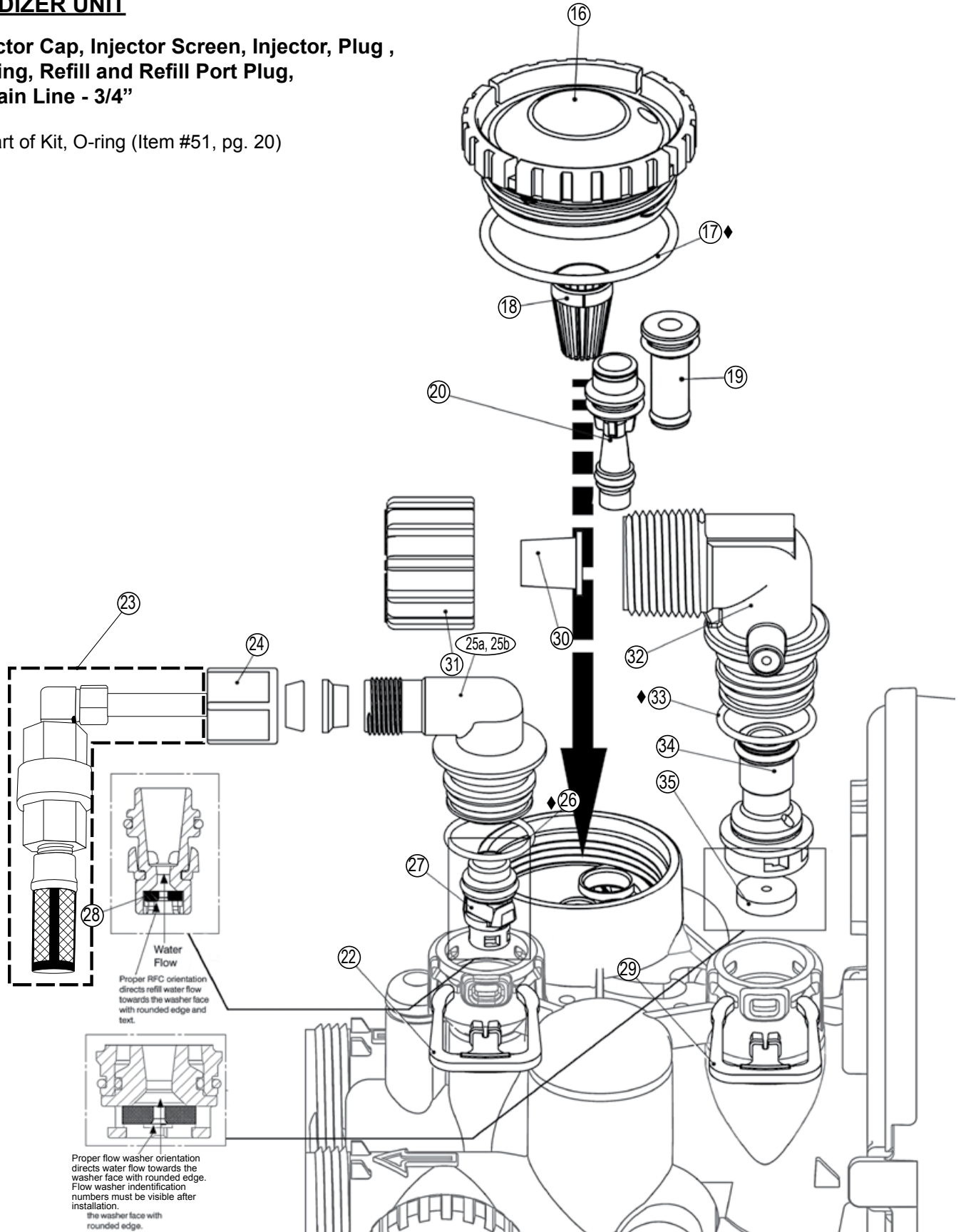

OXIDIZER UNIT

Injector Cap, Injector Screen, Injector, Plug and O-Ring

Item No.	Part No.	Description	Quantity
16	A2080079	Injector Cap	1
◆ 17	Use Item 51	O-Ring 135 (Use Valve O-ring Kit)	1
18	A2142016	Injector Screen	1
19	A2079059	Injector Assembly Z Plug	1
20	A2079063	Injector Assembly K Light Green	1

*The injector plug and the injector each contain one 011 (lower) and 013 (upper) o-ring.
 Note: For downflow brine, injector is located in the down hole and injector plug in the up hole.
 For a filter that only backwashes injector plugs are located in both holes.

Refill and Refill Port Plug

Item No.	Part No.	Description	Quantity
22	A2411015	Injector Cap	1
23	B1025002	Check Valve	1
24	A2095071	Nut 3/8	1
25a	A2080078	Elbow Cap 3/8	1
25b	A2129100	Elbow 1/2" with nut and insert	1
◆ 26	Use Item 51	O-Ring 019 (Use Valve O-ring Kit)	1
27	A2104033	RFC Retainer Assembly*	1
28	A2253108	RFC Brine Refill Flow Washer	1

*Assembly includes RFC.

Drain Line - 3/4"

Item No.	Part No.	Description	Quantity
29	A2411015	Elbow Locking Clip	1
30	A2409013	Polytube insert 5/8	1
31	A2095065	Nut 3/4 Drain Elbow	1
32	A2099056	Drain Elbow 3/4 Male Assembly	1
◆ 33	Use Item 51	O-Ring 019 (Use Valve O-ring Kit)	1
34	A2104034	Drain Flow Washer Retainer Assembly	1
35	A2253111	Drain Flow Washer 6.5 gpm for 3/4	1

FILTRATION UNIT

**Injector Cap, Injector Screen, Injector, Plug ,
O-Ring, Refill and Refill Port Plug,
& Drain Line - 3/4"**

◆ Part of Kit, O-ring (Item #51, pg. 20)

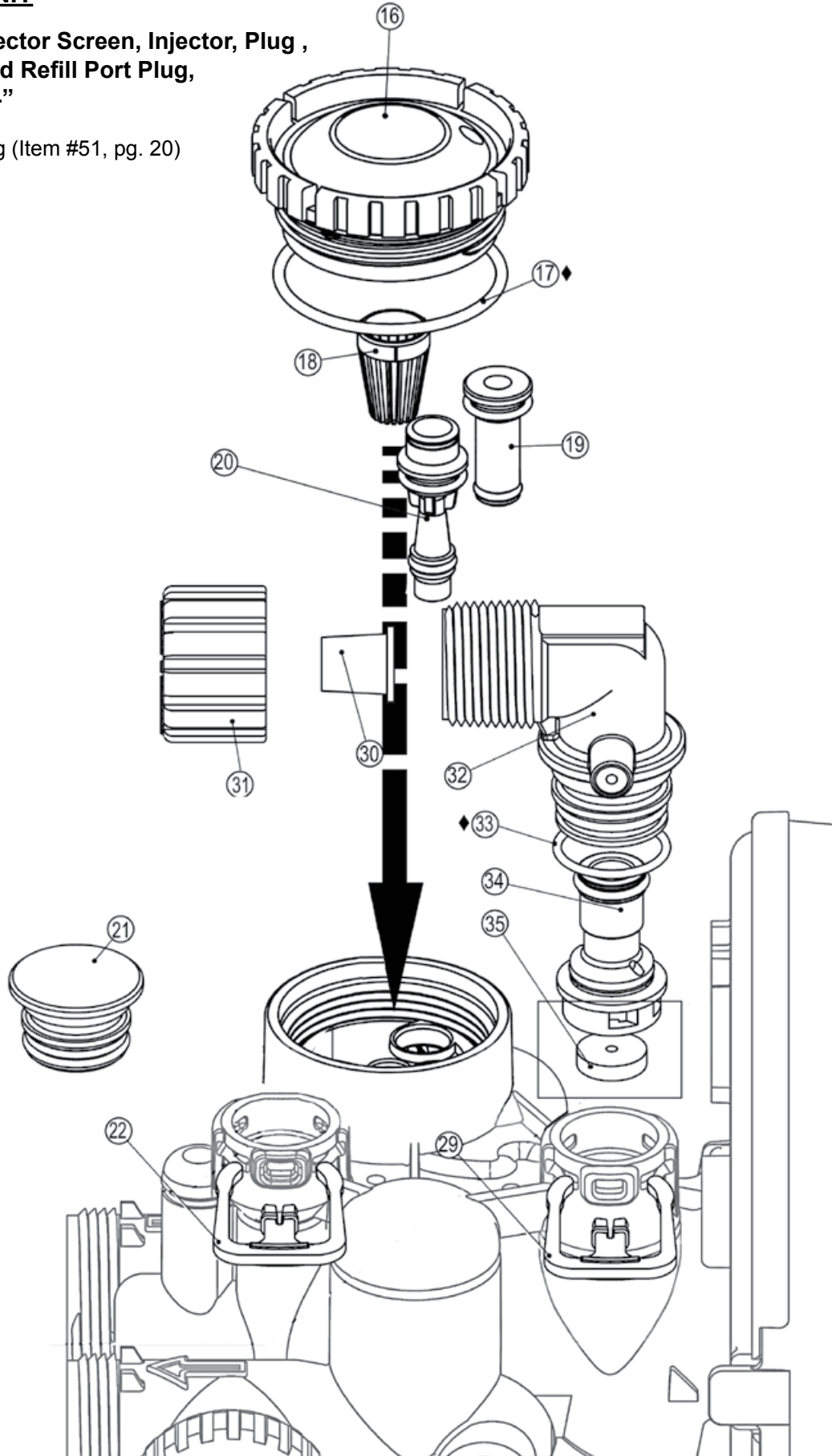

FILTRATION UNIT (parts list)

Injector Cap, Injector Screen, Injector, Plug and O-Ring

Item No.	Part No.	Description	Quantity
16	A2080079	Injector Cap	1
◆ 17	Use Item 51	O-Ring 135 (Use Valve O-ring Kit)	1
18	A2142016	Injector Screen	1
19	A2079059	Injector Assembly Z Plug	1

*The injector plug and the injector each contain one 011 (lower) and 013 (upper) o-ring.
 Note: For downflow brine, injector is located in the down hole and injector plug in the up hole.
 For a filter that only backwashes injector plugs are located in both holes.

Refill and Refill Port Plug

Item No.	Part No.	Description	Quantity
21	A2287059	Refill Port Plug Assembly	Required for backwash only systems
22	A2411015	Elbow Locking Clip	1

Drain Line - 3/4"

Item No.	Part No.	Description	Quantity
29	A2411015	Elbow Locking Clip	1
30	A2409013	Polytube insert 5/8	1
31	A2095065	Nut 3/4 Drain Elbow	1
32	A2099056	Drain Elbow 3/4 Male Assembly	1
◆ 33	Use Item 51	O-Ring 019 (Use Valve O-ring Kit)	1
34	A2104034	Drain Flow Washer Retainer Assembly	1
35	A2253111	Drain Flow Washer 6.5 gpm for 3/4	1

WATER METER AND METER PLUG

Item No.	Part No.	Description	Quantity
36	A2095069	Nut 1" Quick Connect	1
*37	A2360039	Meter Assembly (not standard)	1
38	A2100027	Turbine Assembly	1
39	use item 51	O-Ring 215 (Use Valve O-ring Kit)	1
40	A2287077	Meter Plug Assembly	1

*Item #37 includes Items #38 & #39.

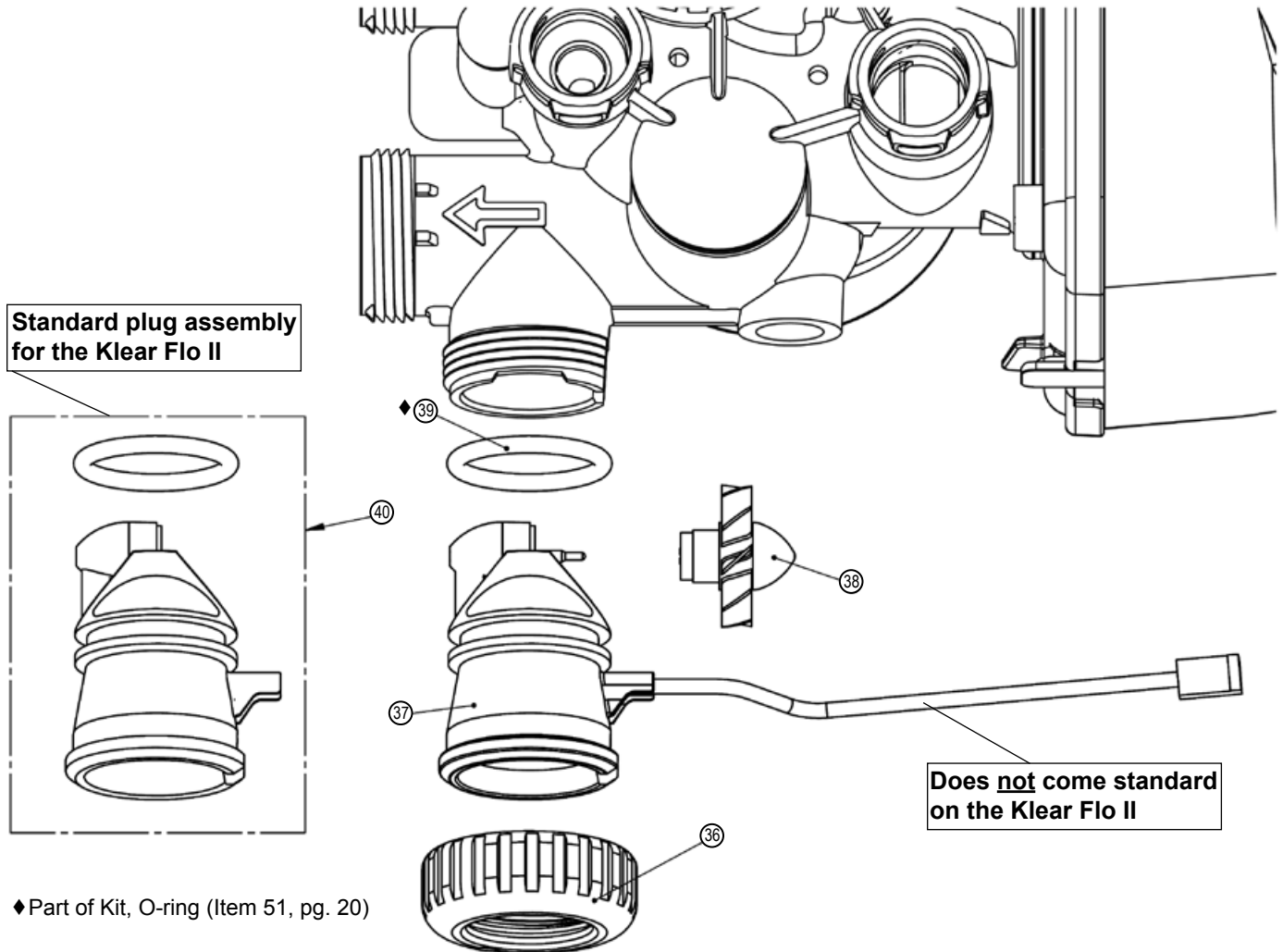

BYPASS VALVE

Item No.	Part No.	Description	Quantity
41	A2095069	Nut 1" Quick Connect	1
42	A2453012	Split Ring	1
* 43	use item 52	O-Ring 215 (Kit available - see Item #10)	1
44	A2607004	Bypass 1" Rotor	1
45	A2080090	Bypass Cap	1
46	A2395009	Bypass Handle	1
47	A2104036	Bypass Rotor Seal Retainer	1
* 48	use item 52	O-Ring 135 (use Bypass Valve Kit)	1
* 49	use item 52	O-Ring 112 (use Bypass Valve Kit)	1
* 50	use item 52	O-Ring 214 (use Bypass Valve Kit)	1

*Part of Kit, O-ring By-Pass (Item 52)

VALVE O-RING KIT

Item No.	Part No.	Description	Quantity
51 (not shown)	B1213022	KIT O-ring (contains 1 each of 3, 6, 15, 17, 26, & 33)	1 per valve

***BYPASS VALVE O-RING KIT**

Item No.	Part No.	Description	Quantity
52	B1213021	KIT O-ring (contains 2 each of 43,48,49 & 50)	1 per valve

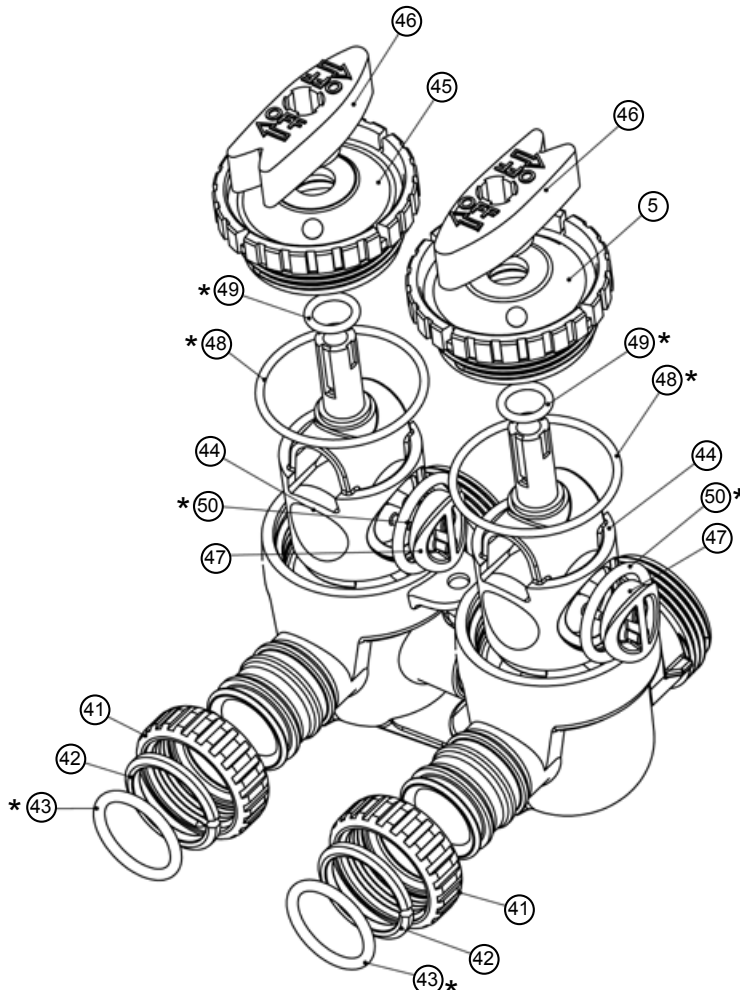

VALVE FITTINGS

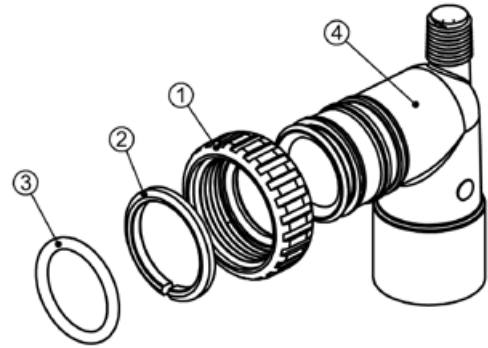
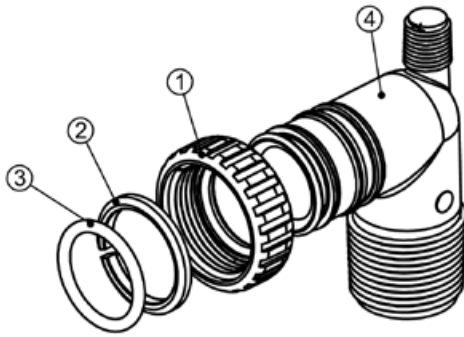

Order No: A2129080 (Optional)			
Description: Fitting 1" PVC Male NPT Elbow Assembly			
Item No.	Part No.	Description	Quantity
1	A2095069	Nut 1" Quick Connect	2
2	A2453012	Split Ring	2
3	A2077178	O-Ring 215	2
4	A2129101	Fitting 1" PVC Male NPT Elbow	2

Order No: A2099054 (Optional)			
Description: Fitting 3/4" & 1" PVC Solvent 90° Asy			
Item No.	Part No.	Description	Quantity
1	A2095069	Nut 1" Quick Connect	2
2	A2453012	Split Ring	2
3	A2077178	O-Ring 215	2
4	A2569008	Fitting 3/4"&1" PVC Solvent 90	2

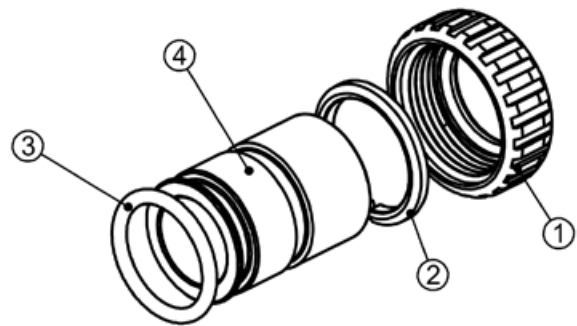
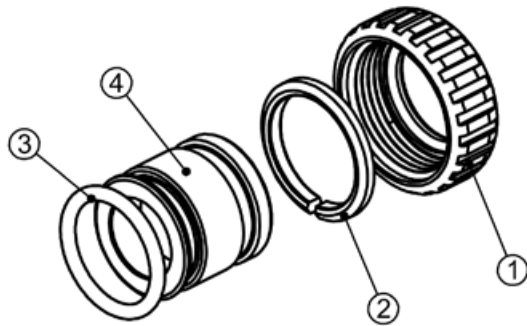

Order No: A2435068 (Standard)			
Description: Fitting 1" Brass Sweat Assembly			
Item No.	Part No.	Description	Quantity
1	A2095069	Nut 1" Quick Connect	2
2	A2453012	Split Ring	2
3	A2077178	O-Ring 215	2
4	A2569006	Fitting 1" Brass Sweat	2

Order No: A2435072 (Optional)			
Description: Fitting 3/4" Brass Sweat Assembly			
Item No.	Part No.	Description	Quantity
1	A2095069	Nut 1" Quick Connect	2
2	A2453012	Split Ring	2
3	A2077178	O-Ring 215	2
4	A2569008	Fitting 3/4"&1" PVC Solvent 90	2



2227 South Street • P.O. Box 044170 • Racine, WI 53404-7003

Ph. (262) 681-1300 • Fax (262) 681-1318 • Info@Marlo-Inc.com • www.Marlo-Inc.com
