



**INSTALLATION, OPERATION,
AND MAINTENANCE MANUAL**

**MID 10G-18G
1" 2750 TIMECLOCK SERIES
COMMERCIAL WATER CONDITIONERS**

COMPLETE FOR FUTURE REFERENCE:

MODEL NO:

SERIAL NO:

DATE INSTALLED:

DEALER:

Marlo Incorporated
2227 South Street
P.O. Box 044170
Racine, WI 53404-7003
Ph. (262) 681-1300
Fax (262) 681-1318
Info@Marlo-Inc.com
www.Marlo-Inc.com

Please Circle and/or Fill in the Appropriate Data for Future Reference:

Filter Model: ACA/AGA/MID/MGA
System Size: Single/Twin/Triple/Quad
Configuration: Timeclock/Pressure Differential/Metered
BW/Regen Time: _____ AM/PM or OFF

Additional Notes: _____

IMPORTANT PLEASE READ:

- Warranty of this product extends to manufacturing defects.
- The information, specifications and illustrations in this manual are based on the latest information available at the time of printing. The manufacturer reserves the right to make changes at any time without notice.
- This product should be installed by a plumbing professional on potable water systems only.
- This product must be installed in compliance with all local and state and municipal plumbing and electrical codes. Permits may be required at the time of installation.
- If operating pressure exceeds 100 psi a pressure reducing valve must be installed. If operating pressure drops below 30 psi a booster pump must be installed.
- Do not install the unit where temperatures may drop below 32°F or rise above 100°F.
- A prefilter should be used on installations in which free solids are present.
- A constant voltage of 120V/60Hz (unless otherwise specified) must be supplied to the controller to maintain proper function.
- Union or flange fittings are recommended at the control valve's inlet, outlet, and drain connections
- If distance of drain line is over a 10 ft. vertical or 25 ft. horizontal run, increase drain line one pipe size over that provided on the control valve.
- Do not make a direct connection to the drain. Provide an air gap of at least four times the diameter of the pipe to conform to sanitation codes and to permit observation of the flow.

TABLE OF CONTENTS**SYSTEM INFORMATION**

Product Warranty.....	1
General Arrangement Drawings	2
Specification Table	4

INSTALLATION

Separate Source Backwash (Optional)	5
Aux Switch (Optional)	7
General Information.....	9
Loading Filter	9
Mounting Control Valve	10
Piping Installation	10

OPERATION

Start-Up Procedure	11
Setting the Time of Day	12
Setting the Day of Regeneration	12
Manual Regeneration	12
Setting the Regeneration Time	13

MAINTENANCE

Wiring Diagram	14
3200 Timer Assembly	15
Powerhead Assembly	17
Control Valve Assembly.....	18
Service Assemblies	20
Troubleshooting.....	21

COMMERCIAL AND INDUSTRIAL PRODUCT WARRANTY

Marlo, Inc. warrants all commercial and industrial water treatment products manufactured and/or distributed by it to be free from defects in materials and workmanship for a period of one (1) year from the date of shipment. If within that period any products shall be proven to Marlo, Inc.'s satisfaction to be defective, those products will be replaced or the price refunded at Marlo Inc.'s option.

Marlo Inc.'s obligations or nonperformance, defective, or any damage caused by its products or their use, and buyer's exclusive remedy therefore, shall be limited to product replacement or refund and shall be conditioned upon Marlo Inc.'s receiving written notice together with a demand for such replacement or refund:

The foregoing warranty is exclusive and in lieu of all other expressed implied warranty (except of title) including but not limited to implied warranty of merchantability and fitness for particular purpose.

Marlo Inc. will not be subject to and disclaims the following:

1. Any other obligations or liabilities arising out of breach of contract or out of warranty.
2. Any obligations whatsoever arising from tort claims (including negligence and strict liability) or arising under other theories of law with respect to products sold or services rendered by Marlo Inc. or any undertakings, acts, or omissions relating thereto.
3. All consequential, incidental, and contingent damages. Labor charges, change backs or handling charges are excluded from Marlo Inc.'s warranty provisions.

COMMERCIAL AND INDUSTRIAL WATER CONDITIONER GUARANTEE

Under normal operating conditions:

1. The loss of filter media through attrition during the first three (3) years shall not exceed 3% per year.
2. The filter media shall not be washed out of the system during backwash.
3. The color and turbidity of the softener effluent shall not be greater than the incoming water.

Any mechanical equipment proving defective in workmanship or material within one year after installation or eighteen (18) months after shipment, whichever comes first, shall be replaced FOB factory.

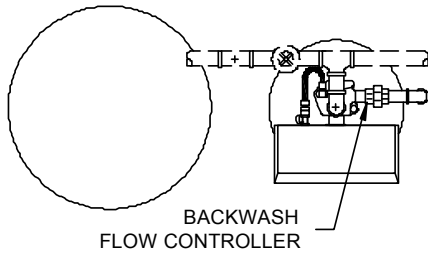

NOTES:

ALL PIPING, FITTINGS,
ECT. SHOWN IN DOTTED
LINES ARE SUPPLIED
BY OTHERS.

GENERAL PLUMBING
CONNECTIONS ARE
SHOWN FOR CLARITY
ONLY.

CONSULT I/O MANUAL
FOR EXACT PLUMBING
CONNECTIONS OF THE
CONTROL VALVE.

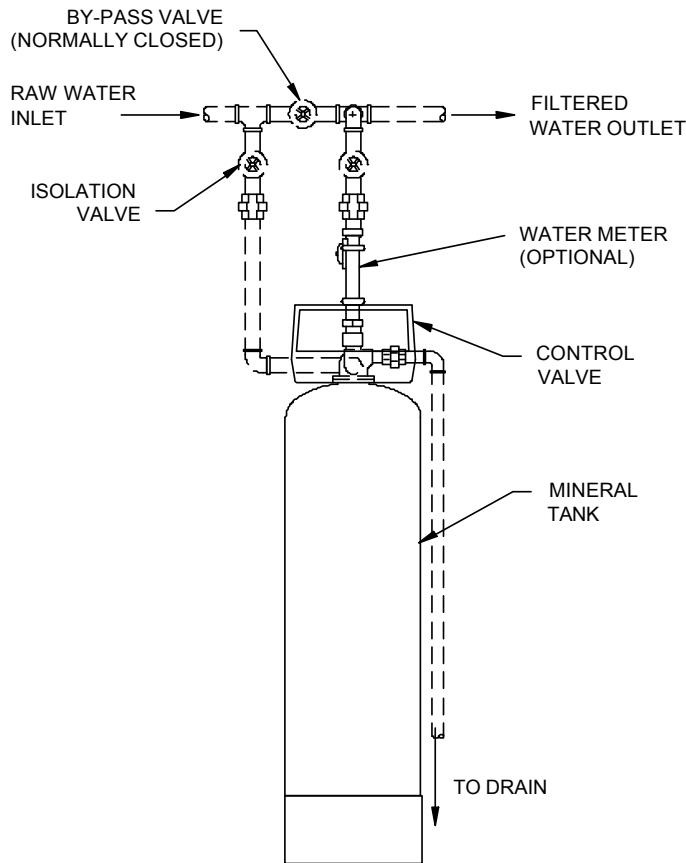

**PRESSURE GAUGE &
SAMPLE VALVE OPTION**

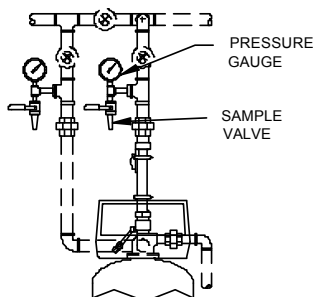

**DIFFERENTIAL PRESSURE
SWITCH INITIATION OPTION**

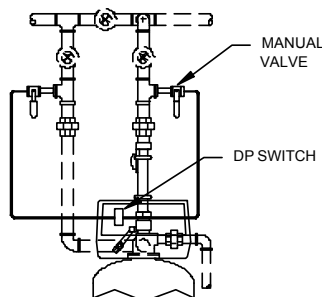

**SEPARATE SOURCE
BACKWASH OPTION**

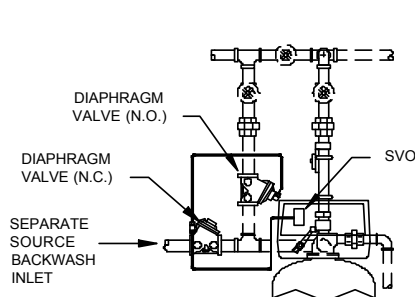

MFG 1" (2750) SINGLE FILTER GENERAL ARRANGEMENT DRAWING		FILE ID. MFG 2750 SINGLE	SHEET 1 OF 1	REV. 0
FRAC. ±	DEC. ±	SCALE	NTS	DRAWING NO.
DRN.	BCD			
APPD.				
DATE	7-13-94			

**CONTROL VALVE FILTER
STANDARD**

REVISIONS		REMARKS
NO.	DATE	BY

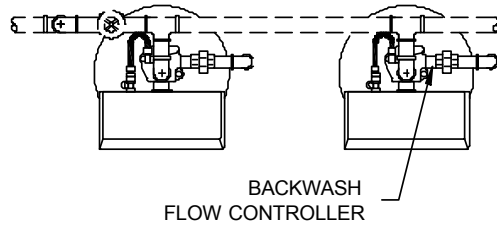

NOTES:

ALL PIPING, FITTINGS, ECT. SHOWN IN DOTTED LINES ARE SUPPLIED BY OTHERS.

GENERAL PLUMBING CONNECTIONS ARE SHOWN FOR CLARITY ONLY.

CONSULT I/O MANUAL FOR EXACT PLUMBING CONNECTIONS OF THE CONTROL VALVE.

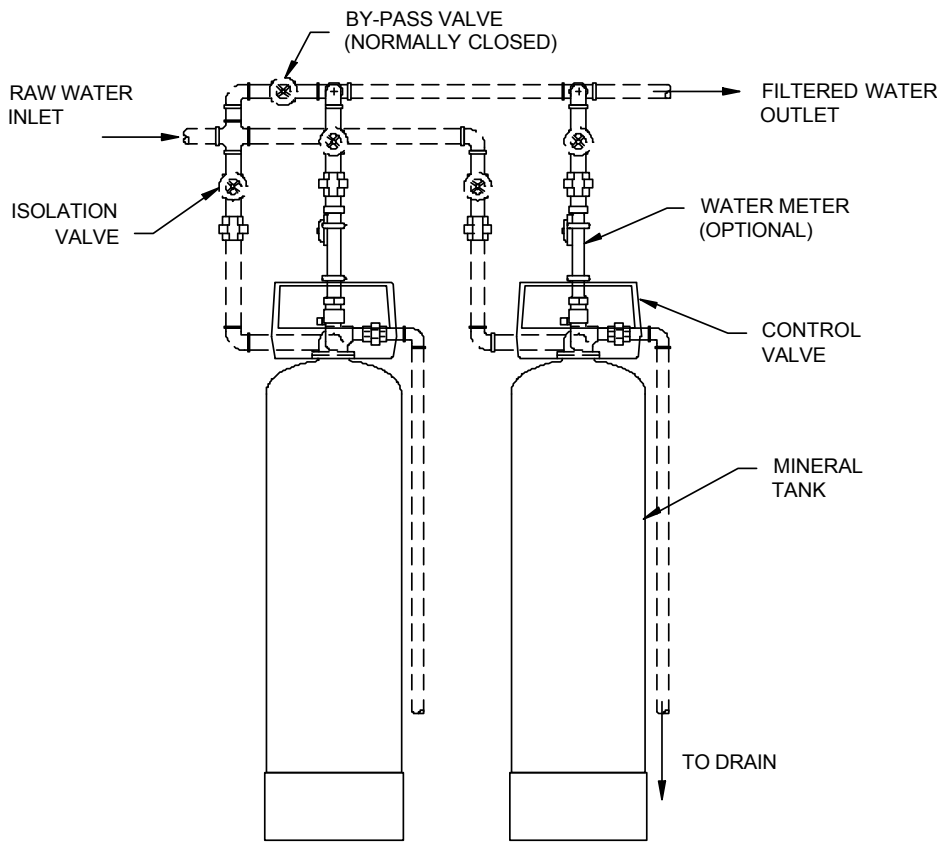

PRESSURE GAUGE & SAMPLE VALVE OPTION

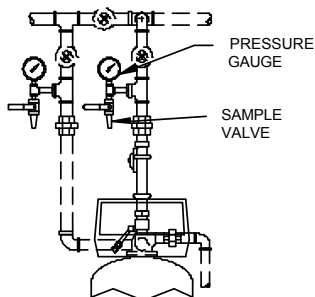

DIFFERENTIAL PRESSURE SWITCH INITIATION OPTION

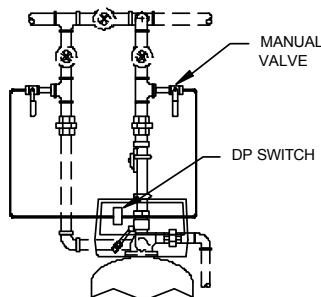

SEPARATE SOURCE BACKWASH OPTION

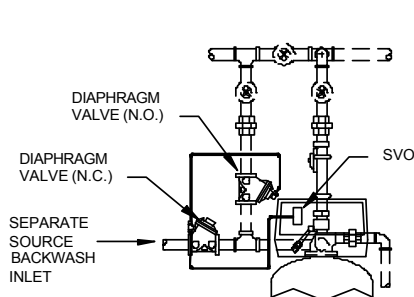

MFG 1" (2750) TWIN FILTER GENERAL ARRANGEMENT DRAWING		FILE ID:	MFG 2750 TWIN	SHEET	1	OF	1	REV.	0
		FRAC. #	DEC. #	BCD	SCALE	NTS	DRAWING NO.	DATE	5-9-03

CONTROL VALVE FILTER STANDARD									

REVISIONS		REMARKS	
NO.	DATE	BY	

SPECIFICATION CHART

MODEL MID -		10G	12G	14G	16G	18G	
SYSTEM SIZE	Service Connection (in)	1	1	1	1	1	
	Drain Connection (in)	3/4	3/4	3/4	3/4	3/4	
FLOWRATE (GPM)	Service - Normal (gpm)	5	8	10	14	17	
	Service - DP (gpm)	2	5	4	6	8	
	Service - Peak (gpm)	10	16	20	28	34	
	Service - DP (gpm)	6	10	13	21	29	
	Backwash & Fast Flush (gpm)	8	12	15	20	25	
	Settle (gpm)	0	0	0	0	0	
TIMER SETTINGS	Backwash	Pins	8	8	8	8	8
		Minutes	16	16	16	16	16
	Settle	Pins	3	3	3	3	3
		Minutes	6	6	6	6	6
	Fast Flush	Pins	3	3	3	3	3
		Minutes	6	6	6	6	6
	Settle	Pins	2	2	2	2	2
		Minutes	4	4	4	4	4
	Return to Service	Pins	2	2	2	2	2
		Minutes	4	4	4	4	4
	TANK	Size - Dia. x Ht. (in)	10x54	12x52	14x65	16x65	18x65
		Gravel Subfill (lbs)	20	40	60	80	80
Media		1	2	3	4	5	
MEDIA LOADING AMOUNTS (LBS)	Anthracite - Top Layer	28	56	73	95	123	
	Red Sand	30	60	80	100	135	
	Garnet 30-40	30	55	75	95	120	
	Garnet 8-12	20	40	55	70	90	
	Gravel - Bottom Layer	20	40	60	80	80	

VOLUME (Cu. Ft.) VERSUS WEIGHT (LBS) OF MEDIA		
ANTHRACITE "C"	56# per Cu. Ft.	1 Cu. Ft. per bag
RED SAND	100# per Cu. Ft.	100# per bag
GARNET 30-40	130# per Cu. Ft.	50# per bag
GARNET 8-12	140# per Cu. Ft.	50# per bag
GRAVEL	100# per Cu. Ft.	100# per bag
NOTE: Bag size may vary. Please confirm weight and volume before loading. Consult Media sheets on media pallet.		

SEPARATE SOURCE BACKWASH (OPTIONAL)

This option allows the filter to use a separate water source for backwashing the system. The separate source uses diaphragm valves to control the flow of the backwash water. The diaphragm valves are controlled by a SVO (Service Valve Operator) that is mounted to the filter valve backplate.

The piston in the SVO Valve is actuated by a cam on the filter valve motor shaft. Extending the piston will allow Raw Water flow. Depressing the piston will allow Separate Source water flow.

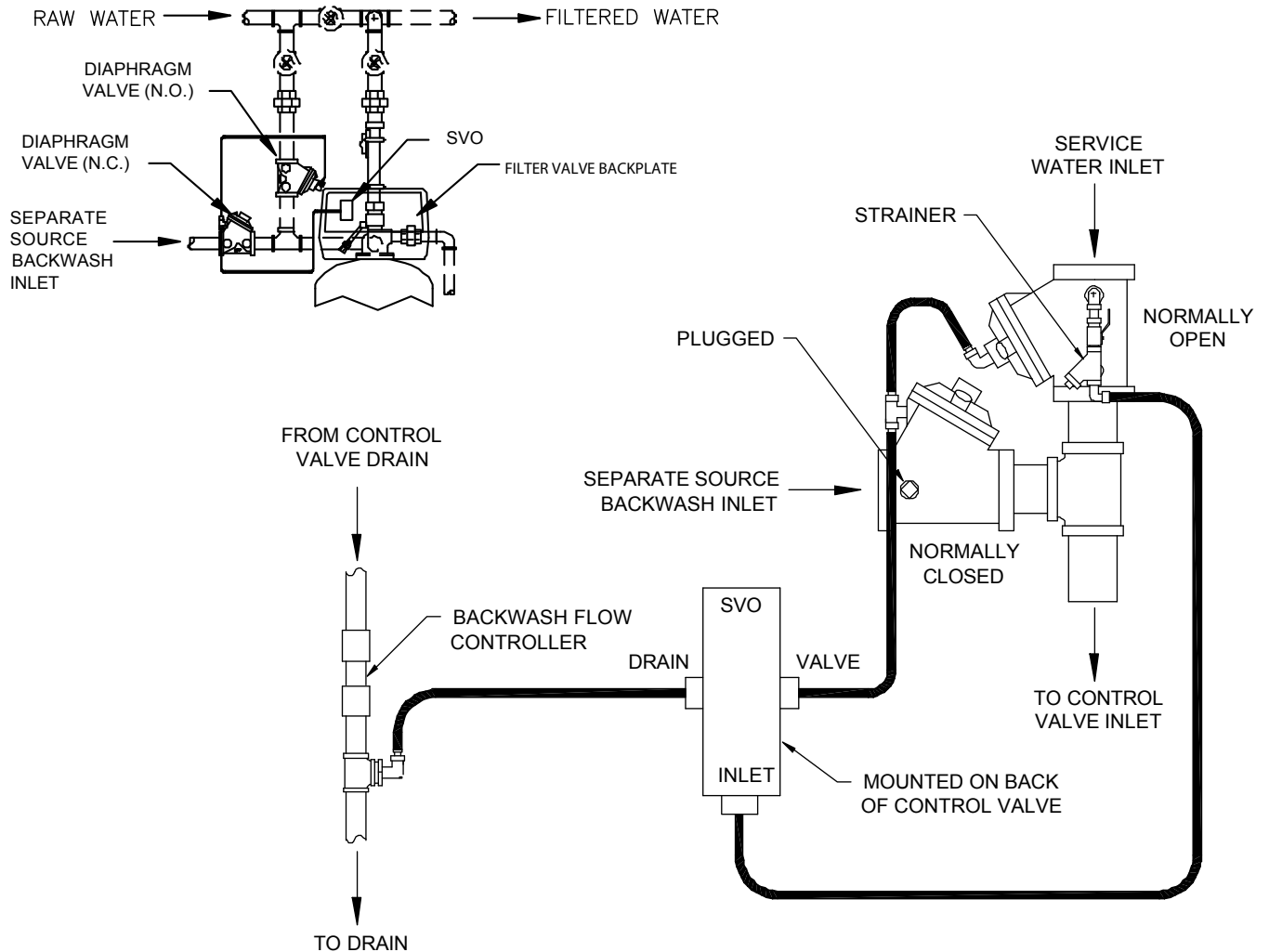

ACTUAL SVO PORT LOCATIONS MAY VARY.

DRAWING IS SHOWN FOR CLARITY ONLY.

INSTALL THE STRAINER ASSEMBLY INTO THE INLET BOSS OF THE VALVE WITH THE HIGHEST PRESSURE. PLUG THE OTHER VALVE'S INLET BOSS.

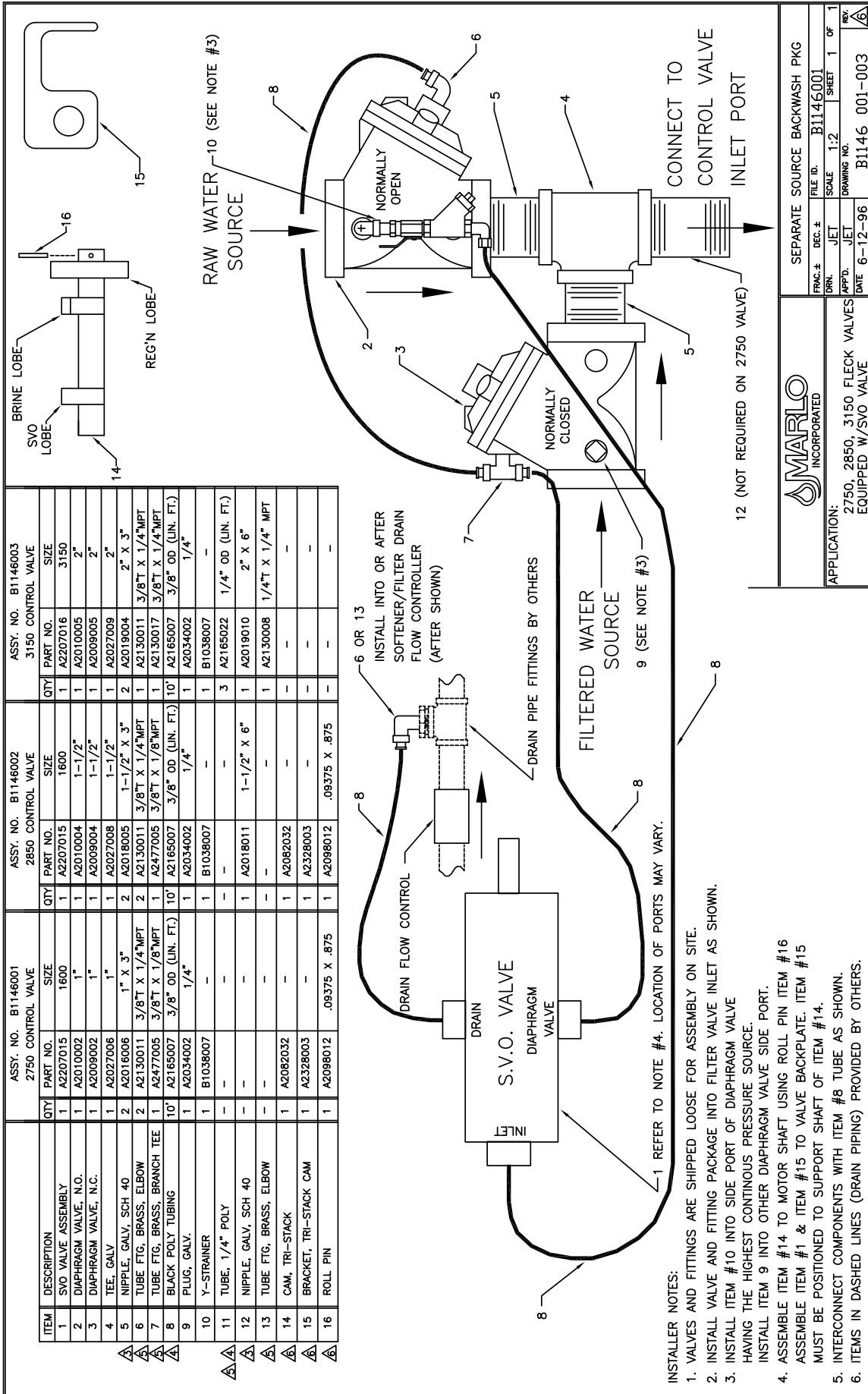

ASSY. NO. B1146001 2750 CONTROL VALVE			ASSY. NO. B1146002 2850 CONTROL VALVE			ASSY. NO. B1146003 3150 CONTROL VALVE				
ITEM	DESCRIPTION	QTY	PART NO.	SIZE	QTY	PART NO.	SIZE	QTY	PART NO.	SIZE
1	S.V.O. VALVE ASSEMBLY	1	A2207015	1600	1	A2207015	3150	1	A2207015	3150
2	DIAPHRAGM VALVE, N.O.	1	A2010002	1"	1	A2010004	1-1/2"	1	A2010005	2"
3	DIAPHRAGM VALVE, N.C.	1	A2009002	1"	1	A2009004	1-1/2"	1	A2009005	2"
4	TEE, GALV.	1	A2027006	1"	1	A2027008	1-1/2"	1	A2027009	2"
5	NIPPLE, GALV, SCH 40	2	A2016006	1" X 3"	2	A2018005	1-1/2" X 3"	2	A2019004	2" X 3"
6	TUBE FTG. BRASS, ELBOW	2	A2130011	3/8" T X 1/4" MPT	2	A2130011	3/8" T X 1/4" MPT	2	A2130011	3/8" T X 1/4" MPT
7	TUBE FTG. BRASS, BRANCH TEE	1	A2477005	3/8" T X 1/8" MPT	1	A2477005	3/8" T X 1/8" MPT	1	A2130017	3/8" T X 1/4" MPT
8	BLACK POLY TUBING	10'	A2165007	3/8" OD (LIN. FT.)	10'	A2165007	3/8" OD (LIN. FT.)	10'	A2165007	3/8" OD (LIN. FT.)
9	PLUG, GALV.	1	A2034002	1/4"	1	A2034002	1/4"	1	A2034002	1/4"
10	Y-STRAINER	1	B1038007	-	1	B1038007	-	1	B1038007	-
11	TUBE, 1/4" POLY	-	-	-	-	-	-	3	A2165022	1/4" OD (LIN. FT.)
12	NIPPLE, GALV, SCH 40	-	-	-	1	A2018011	1-1/2" X 6"	1	A2019010	2" X 6"
13	TUBE FTG. BRASS, ELBOW	-	-	-	-	-	-	1	A2130008	1/4" T X 1/4" MPT
14	CAM, TRI-STACK	1	A2082032	-	-	-	-	-	-	-
15	BRACKET, TRI-STACK CAM	1	A2328003	-	1	A2328003	-	-	-	-
16	ROLL PIN	1	A2098012	.09375 X .875	1	A2098012	.09375 X .875	-	-	-

- INSTALLER NOTES:**
1. VALVES AND FITTINGS ARE SHIPPED LOOSE FOR ASSEMBLY ON SITE.
 2. INSTALL VALVE AND FITTING PACKAGE INTO FILTER VALVE INLET AS SHOWN.
 3. INSTALL ITEM #10 INTO SIDE PORT OF DIAPHRAGM VALVE HAVING THE HIGHEST CONTINUOUS PRESSURE SOURCE. INSTALL ITEM 9 INTO OTHER DIAPHRAGM VALVE SIDE PORT.
 4. ASSEMBLE ITEM #14 TO MOTOR SHAFT USING ROLL PIN ITEM #16 ASSEMBLE ITEM #1 & ITEM #15 TO VALVE BACKPLATE. ITEM #15 MUST BE POSITIONED TO SUPPORT SHAFT OF ITEM #14.
 5. INTERCONNECT COMPONENTS WITH ITEM #8 TUBE AS SHOWN.
 6. ITEMS IN DASHED LINES (DRAIN PIPING) PROVIDED BY OTHERS.

MARLO
INCORPORATED

APPLICATION:
2750, 2850, 3150 FLECK VALVES
EQUIPPED W/SVO VALVE

SEPARATE SOURCE BACKWASH PKG

FRAC.#	DEC.#	FILE ID.	B1146001
DRN.	JET	SCALE	1:2
APP'D.	JET	DRAWING NO.	B1146 001-003
DATE	6-12-96		

12 (NOT REQUIRED ON 2750 VALVE)

AUX SWITCH (OPTIONAL)

The Aux Switch Option provides an extra switch on the brine valve cam assembly that ties to the terminal strip located on the back-plate of the valve. The switch provides a dry contact circuit that changes status dependent on filter valve's step. It is most commonly used to lockout an RO activate a pump, or activate separate source inlet valves.

The switch is normally closed during service and normally open during regeneration.

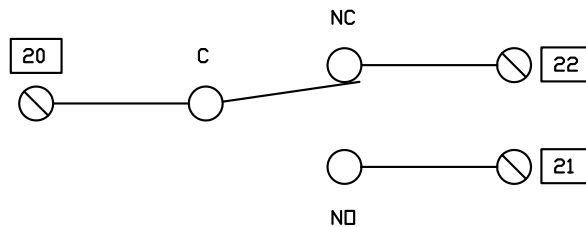
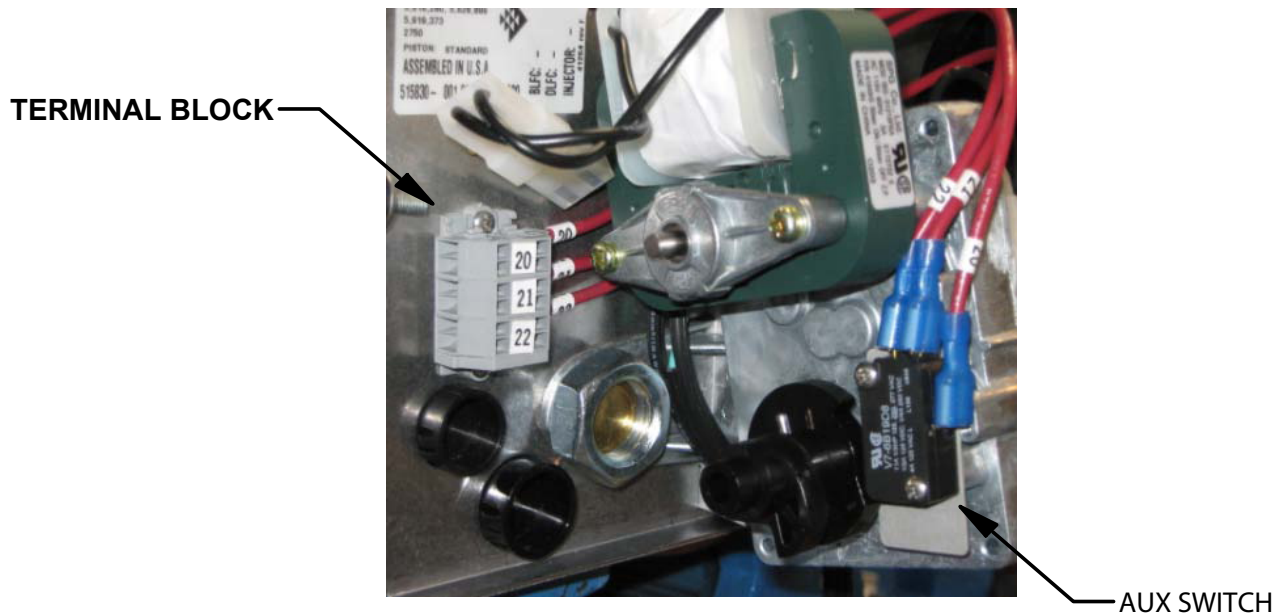

STEP	DRY CONTACT STATUS	
	OPEN	CLOSED
SERVICE	20-21	20-22
BACKWASH// REGENERATION	20-22	20-21

Contact Rating: 220 VAC Max. / 2.0 AMP Max.

AUX SWITCH (OPTIONAL)

PN	QTY	DESCRIPTION
MICROSWITCH ASSEMBLY		
A2154001	1	MICROSWITCH VALVE / STAGER RD LOCKOUT
A2083027	2	SCREW 4-40 X 1/2 SELF TAP PHIL MACH
A2490014	1	CAM SHUTOFF VALVE (12777)
A2098012	1	ROLL PIN .09375 X .875 (10338)
A2158001	1	INSULATOR LIMIT SWITCH (10302)
TERMINAL STRIP ASSEMBLY		
A2445043	1	END STOP W / FIXING FLANGE
A2307015	3	TERMINAL BLOCK GRAY 15A 300V
A2457003	2	SCREW 6-32 X 3/8 MACH RD HD SS
A2095048	2	6-32 NUTS SS
A2486021	2	WASHER LOCK #6 SPLIT SS
A2173009	3 FT	WIRE 16 RED

CONSTRUCTION NOTES:

1. INSTALL MICROSWITCH ASSEMBLY NEXT TO BRINE VALVE CAM ASSEMBLY ON VALVE.
2. INSTALL THE 3 TERMINALS AND LABEL THE TERMINALS NUMBERS 20, 21, 22.
3. WIRE THE MICROSWITCH USING 16 AWG RED WIRE.
4. WIRE AS FOLLOWS:

COMMON TO 20
NORMALLY OPEN TO 21
NORMALLY CLOSED TO 22

LOCKOUT SWITCH NOTES:

2900 AND 3900 VALVE ALREADY USES THIS SWITCH FOR ITS OPERATION.
3150 VALVE SYSTEM 4. THIS SWITCH IS ALREADY INSTALLED ON THE VALVE
AND IS AVAILABLE FOR RD LOCKOUT USE.

WIRING DIAGRAM OF AUXILIARY SWITCH (5 AMP MAXIMUM)

SWITCH ON NORMALLY CLOSED SIDE DURING SERVICE. NORMALLY OPEN DURING REGENERATION.

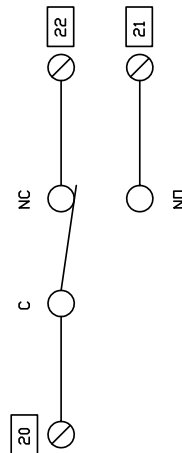

NO.	DATE	BY	REVISIONS	REMARKS

FRAC.#	REC.#
FILE NO.	B1055006
SCALE	N.T.S.
SHEET	1 OF 1
DATE	2-3-04
DRAWING NO.	B1055006

INSTALLATION INSTRUCTIONS

GENERAL INFORMATION

1. Minimum operating pressure is 25 psi. If pressures less than 25 psi are encountered, a pump must be installed.
2. Maximum operating pressure is 120 psi. If pressures greater than 120 psi are encountered, a pressure regulator must be installed.
3. Power requirements are shown on inside cover of the control valve.
4. Standard units are designed to condition unheated water not to exceed 100° F. Special valve assemblies are available to handle heated water supplies exceeding 100°F. Consult factory if applicable.
5. Each mineral tank is shipped with distributor manifold and control valve preassembled. Take care when uncrating and erecting so that no items are damaged.
6. The distributor assembly has been shipped inside the fiberglass mineral tank. Check to make sure that there is no damage to the riser pipe, basket, laterals, or hub.

LOCATE MINERAL TANKS

1. Select a location that is accessible and near a floor drain that has adequate carrying capacity to handle the water conditioner backwash flow. See specification table for the backwash flow rate.
2. Erect the mineral tanks on a concrete or other firm foundation and level.
3. A grounded electric receptacle is required for the control valves.

LOAD FILTER TANKS

1. On tank sizes 10” and 12” the media has been pre-loaded at the factory. Skip this section and go to “Mount Control Valve Assembly”.
2. Fill tank(s) approximately 1/3 full of water using a hose, bucket, etc. Plug the PVC distributor manifold pipe using a plastic cap, cork, rag, etc. No gravel or resin should go into this distributor manifold pipe.
3. Verify the distributor manifold is center in the tank with the distributor resting on the bottom of the tank. Verify the riser pipe is still plugged.
Note: Reference the specification table in the front of this manual for the correct quantities of gravel and media. Note that these quantities are for each tank. Make sure you have the required amounts on site before you begin.
4. With care not to damage any lateral, pour in the gravel provided for each tank through the top opening in the tank and level out evenly. This will cover the distributor assembly.
Note: Wetting the gravel in the bags before loading will eliminate the normal amount of dust.
5. When gravel is loaded and leveling is completed, proceed as follows:
6. Refer to the specification table for the correct amounts and the order of media. Load the bottom layer first and work your way up to the top layer. With the distributor riser pipe still plugged, add the proper amount of media supplied for each tank through the top opening in the tank and then level the media layer.
7. Repeat step 6 for each type of media.
8. When loading is complete, remove plastic cap, cork, or rag that was used to plug the distributor riser pipe. Be careful not to let any foreign debris fall into the pipe. The result could be damage to system.
9. Repeat instruction steps 1-8 for each media tank.



MOUNT CONTROL VALVE ASSEMBLY

1. Verify that the distributor riser pipe is not plugged.
2. Lubricate the distributor O-ring on the bottom of the control valve with silicone.
3. Insert disperser in threaded base of control valve. The threaded base has a groove machined into the inside of the threaded part of the base to allow for the installation of this disperser.
4. Screw control valve into top opening of tank making sure the distributor riser pipe slides easily through the distributor O-ring. Care must be taken not to “nick” this O-ring as hard water leakage could result.
5. Tighten down the control valve to ensure positive O-ring seal at top of tank.
6. Repeat instruction steps 1-5 for each filter tank.

INSTALLATION OF CONNECTION PIPING**Note:**

- Use thread sealing tape on all threaded piping connections.
- Install the piping conforming to federal, provincial, and local codes.
- Union or flanges are recommended at the control valve’s inlet, outlet, and drain connections
- To enhance the monitoring of the system’s performance sample valves and pressure gauges can be installed at the inlet and outlet piping to each control valve.
- If distance of drain line is over a 10 ft. vertical or 25 ft. horizontal run, increase drain line one pipe size over that provided on the control valve.
- Do not make a direct connection to the drain. Provide an air gap of at least four times the diameter of the pipe to conform to sanitation codes and to permit observation of the flow.

Caution: All piping must be properly supported. The tank and valve assemblies are not meant to support the connecting piping.

1. Install piping as shown on installation diagram. It is recommended that unions be installed on inlet and outlet connections to facilitate service of unit. Be sure piping is free of thread chips and other foreign matter. The connecting piping should be the same size or larger than the service inlet and outlet of the control valve. On multiple units that are both in service at the same time the common service inlet and outlet headers should be up-sized to accommodate the total flow.
2. Verify that the flow arrow stamped on the brass flow controller is pointing away from the control valve. See installation diagram or valve manual for the location. Install a drain line from backwash control assembly to an appropriate drain using a minimum of elbows. Install a union near the backwash control to facilitate cleaning. Do not install a valve on the drain line.

START-UP

1. Make sure all plumbing is complete and tight including drain line(s). Make all electrical connections per wiring diagrams provided.
2. Make sure inlet and outlet isolation valves are closed, and then turn on power to the system.
3. Remove the black plastic cover from the control valve. The regeneration cycle timer is secured to the backplate of the control valve. The timer is hinged on the right side. Grab the upper left corner of the timer and pull towards you. The timer will swing out to the right. The backside of the timer has a program wheel with holes and pins in it. Each hole or pin represents two (2) minutes.

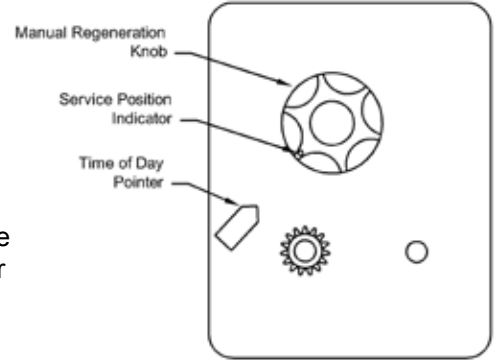

The holes and pins control the regeneration cycle times as follows:

- | | |
|-------------------------------------|-----------------------|
| Step 1 - (Backwash) | First group of pins |
| Step 2 - (Settle) | First group of holes |
| Step 3 - (Fast Rinse) | Second group of pins |
| Step 4 - (Settle) | Second group of holes |
| Step 5 - (Return to Service) | Third group of pins |

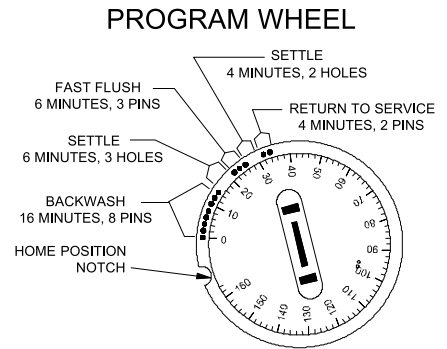

4. Locate the manual regeneration knob on the front side of the timer. Slightly turn the knob clockwise. The control valve will advance to backwash position. Be patient this will take several minutes.
5. Remove electrical power from unit, and then slowly open inlet water valve approximately half open. Water will begin to fill through bottom distributor into tank. When tank is full, water will begin to flow out of drain line. Slowly pen the inlet valve until full open. Allow water to flow from drain line for approximately 15 minutes.

Note: Carbon filters will normally have considerable black fines on the initial backwash and may take 10-15 minutes to run clear. Monitor this drain water flow carefully. There is a problem if you see media in the drain water. Turn off inlet water immediately and then consult factory.
6. Restore electrical power to unit. Advance the control valve to settle position, using the same method as step 5. There should also be to flow at the drain line.
7. Advance the control valve to the fast rinse position. Remove electrical power to the unit. Let water run to drain position for approximately 5 minutes or until water runs clear.
8. Advance control valve to service position.
9. Proceed to start up the next tank (if applicable), by repeating steps 1-8.

SETTING THE TIME / DAY CLOCK

How to set the time of day:

1. Press and hold the red button in to disengage the drive gear.
2. Turn the large gear until the actual time is at the time of day pointer.
3. Release the red button to again engage the drive gear.

How to set days on which the filter is to regenerate:

1. Rotate the skipper wheel until the number "1" is at the red pointer.
2. Set the day that regeneration is to occur by sliding tabs on the skipper wheel outward to expose trip fingers. Each tab is one day. Finger at red pointer is tonight.
3. Moving clockwise from the red pointer, extend or retract fingers to obtain the desired regeneration schedule.

How to manually regenerate your Water Conditioner at any time:

Turn the manual regeneration knob clockwise. This slight movement of the manual regeneration knob engages the program wheel and starts the regeneration program. The manual regeneration knob will make one revolution in approximately three hours and stop in the position shown in the drawing. Even though it takes three hours for this center knob to complete one revolution, the regeneration cycle of your unit might be set only half of this time. In any event, conditioned water may be drawn after rinse water stops flowing from the water conditioner drain line.

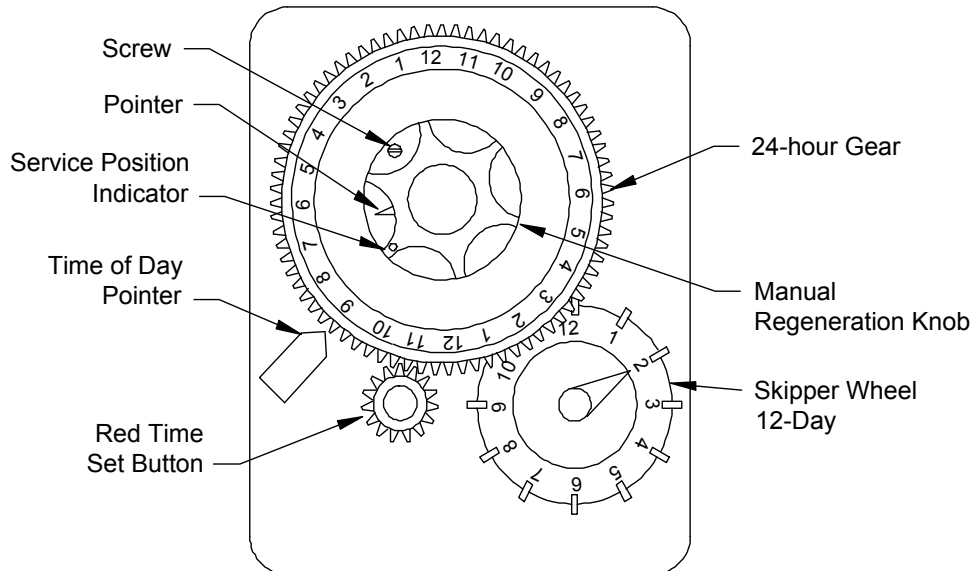

How to adjust the time of day regeneration occurs:

1. Disconnect the power source.
2. Locate the three screws behind the manual regeneration knob by pushing the red button in and rotating the 24-hour dial until each screw appears in the cut out portion of the manual regeneration knob.
3. Loosen each screw slightly to release the pressure on the time plate from the 24-hour gear.
4. Locate the regeneration time pointer on the inside of the 24-hour dial in the cutout. The pointer is hard to see.
5. Turn the time plate so the pointer on the desired regeneration time aligns next to the raised arrow.
6. Push the red button in and rotate the 24-hour dial. Tighten each to the three screws.
7. Push the red button and locate the pointer one more time to ensure the desired regeneration time is correct.
8. Reset the time of day and restore power to the unit.

Note: On twin or triple unit filters with time clock controls, each unit should be set to regenerate on different days or different times to avoid simultaneous regenerations.

Note: The screw and pointer are shown for reference only. There is only one cutout in the knob

SETTING THE REGENERATION CYCLE PROGRAM TIMER

The regeneration cycle program on your water softener has been factory set. However, portions of the cycle program may be lengthened or shortened in time to suit local conditions. The regeneration cycle timer is secured to the back-plate of the control valve. The timer is hinged on the right side. Grab the upper left corner of the timer and pull towards you. The timer will swing out to the right. The backside of the timer has a program wheel with holes and pins in it.

The holes and pins control the regeneration cycle times as follows:

- | | |
|-------------------------------------|-----------------------|
| Step 1 - (Backwash) | First group of pins |
| Step 2 - (Settle) | First group of holes |
| Step 3 - (Fast Rinse) | Second group of pins |
| Step 4 - (Settle) | Second group of holes |
| Step 5 - (Return to Service) | Third group of pins |

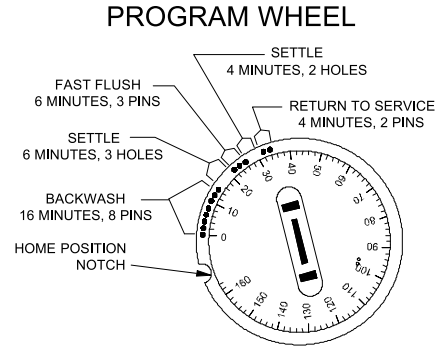

- **Backwash:** The cycle duration is factory set at 16 minutes for clean feed water applications. Increase time if turbidity is present in the feed water.
- **Settle:** The cycle duration is factory set at 6 minutes for clean feed water applications.
- **Fast Flush:** The cycle duration is factory set at 6 minutes.
- **Settle:** The cycle duration is factory set at 4 minutes.
- **Cycle End:** The cycle duration is factory set at 4 minutes. Its purpose is to identify the end of regeneration and advance the filter back to the service cycle.

To adjust the regeneration cycle program it is easier to remove the program wheel by pushing the two black tabs located in the center of the program wheel while pushing up on the program wheel.

As you look at the number side of the program wheel, starting at zero the number of the group of pins determines the length of time that your unit will be in Backwash. If there are six pins in this section, the time of backwash will be 16 minutes (2 minutes per pin). You must add or remove pins to change the length of this time. All the following groups of holes or pins must be adjusted to maintain their original time.

Important: Changing the time duration in any cycle will require a readjustment of all pins and holes for all the following steps.

2750 WIRING DIAGRAM

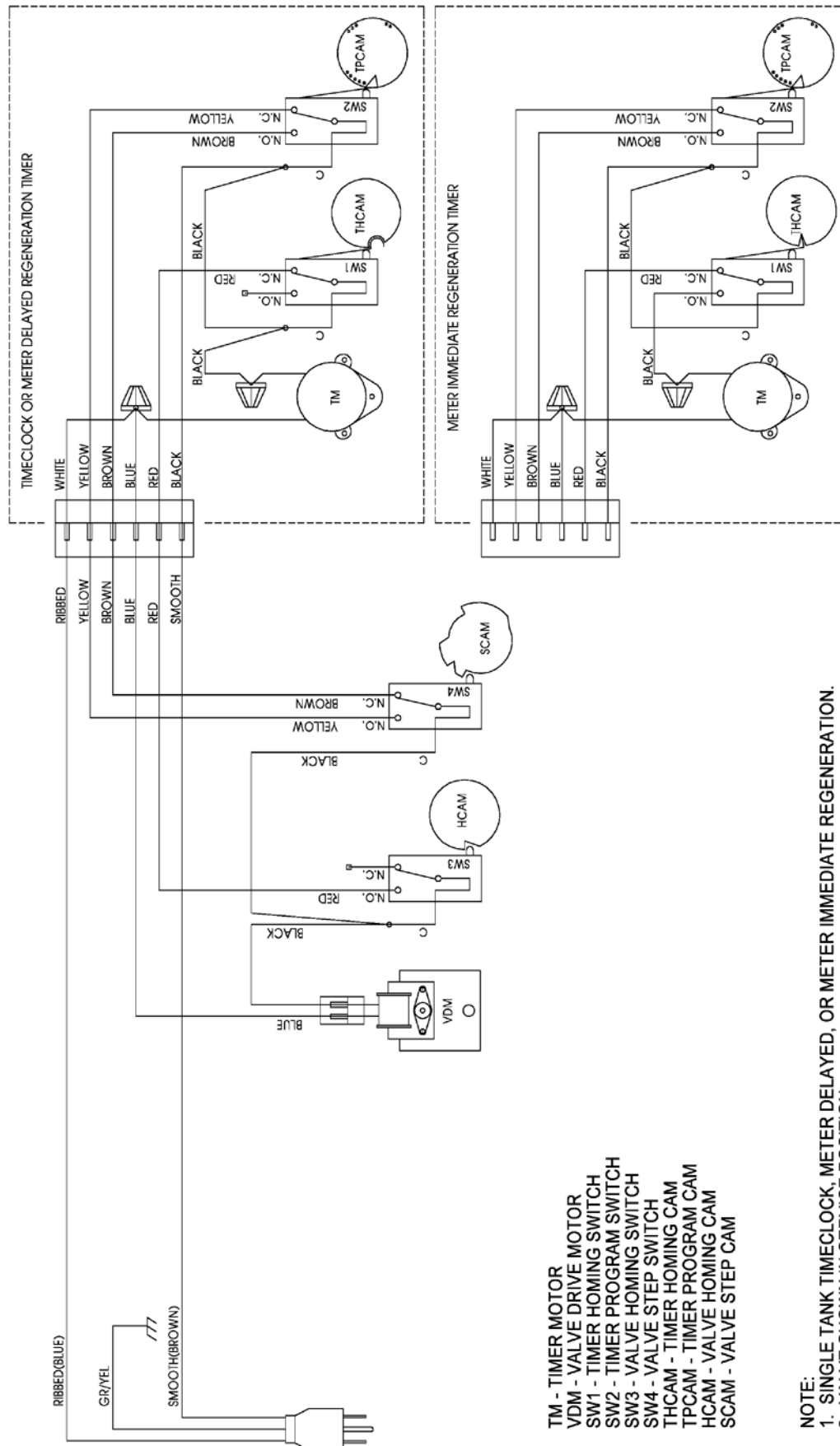

NOTE:
1. SINGLE TANK TIMECLOCK, METER DELAYED, OR METER IMMEDIATE REGENERATION.
2. VALVE SHOWN IN SERVICE POSITION.

3200 TIMER ASSEMBLY

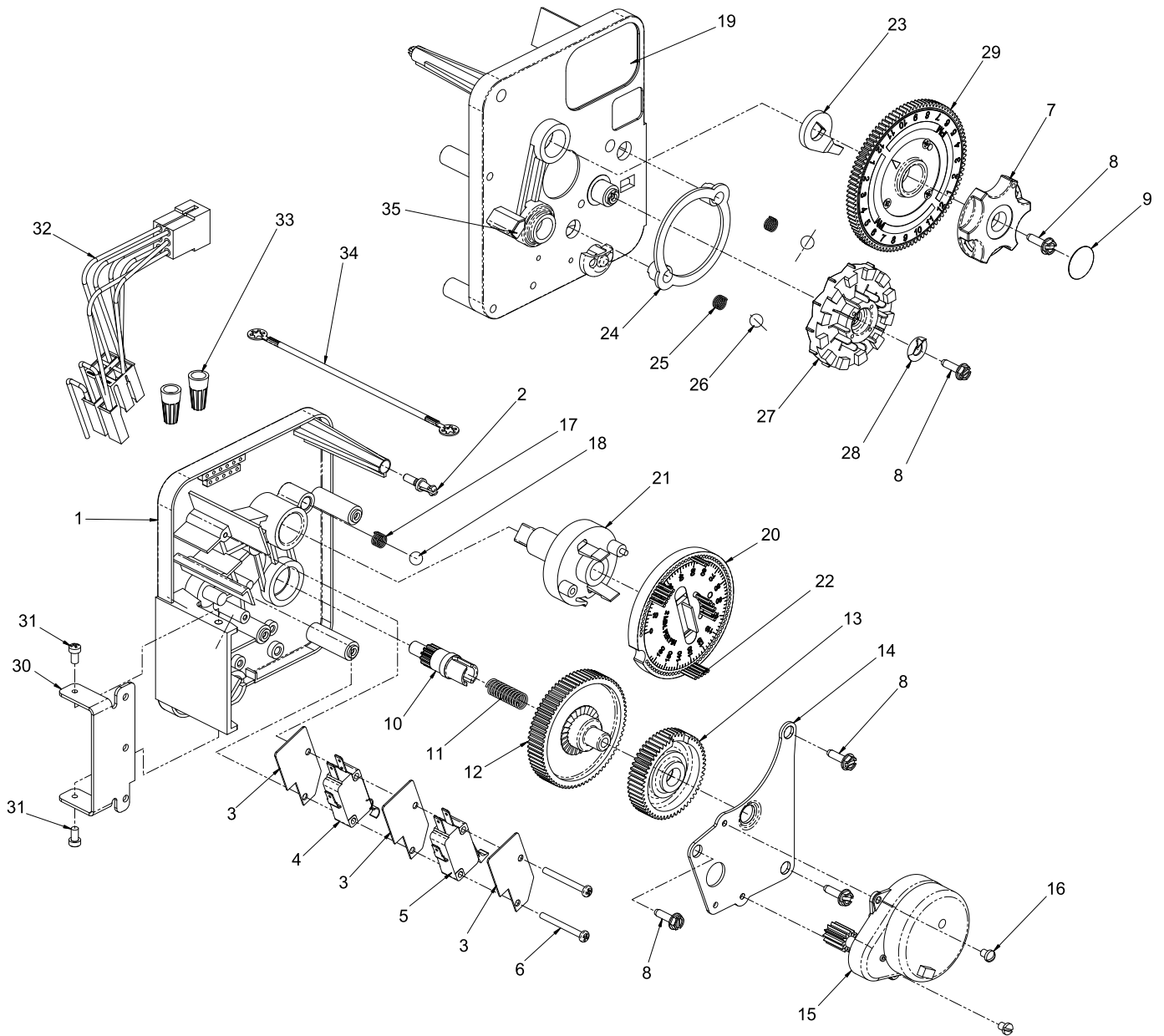

3200 TIMER ASSEMBLY PARTS LIST

Item No.	Quantity	Part No.	Description
1.....	1	13870.....	Housing, Timer, 3200
2.....	1	14265.....	Clip, Spring
3.....	3	14087.....	Insulator
4.....	1	10896.....	Switch, Micro
5.....	1	15320.....	Switch, Micro, Timer
6.....	2	11413.....	Screw, Pan Hd Mach, 4-40 x 1-1/8
7.....	1	13886.....	Knob, 3200
8.....	5	13296.....	Screw, Hex Wsh, 6-20 x 1/2
9.....	1	11999.....	Label, Button
10.....	1	13018.....	Pinion, Idler
11.....	1	13312.....	Spring, Idler Shaft
12.....	1	13017.....	Gear, Idler
13.....	1	13164.....	Gear, Drive
14.....	1	13887.....	Plate, Motor Mounting
15.....	1	18743-1	Motor, 120V, 60Hz, 1/30 RPM, 5600
		19659-1	Motor, 24V, 60Hz, 1/30 RPM
16.....	2	13278.....	Screw, Slt'd Fillister Hd 6-32 x .156
17.....	1	15424.....	Spring, Detent, Timer
18.....	1	15066.....	Ball, 1/4", Delrin
19.....	1	15465.....	Label, Caution
20.....	1	19210.....	Program Wheel Assy
21.....	1	13911.....	Gear, Main Drive, Timer
22.....	17	41754.....	Pin, Spring, 1/16 x 5/8 SS, Timer
23.....	1	13011.....	Arm, Cycle Actuator
24.....	1	13864.....	Ring, Skipper Wheel
25.....	2	13311.....	Spring, Detent, Timer
26.....	2	13300.....	Ball, 1/4", SS
27.....	1	14381.....	Skipper Wheel Assy, 12 Day
		14860.....	Skipper Wheel Assy, 7 Day
28.....	1	13014.....	Pointer, Regeneration
29.....	1	40096-24	Dial, 12 AM Regen Assy, Black
		40096-02	Dial, 2 AM Regen Assy, Black
30.....	1	13881.....	Bracket, Hinger Timer
31.....	2	11384.....	Screw, Phil, 6-32 x 1/4 Zinc
32.....	1	13902.....	Harness, 3200
33.....	2	40422.....	Nut, Wire, Tan
34.....	1	15354-01	Wire, Ground, 4"
35.....	1	14007.....	Label, Time of Day

2750 POWERHEAD - ENVIRONMENTAL

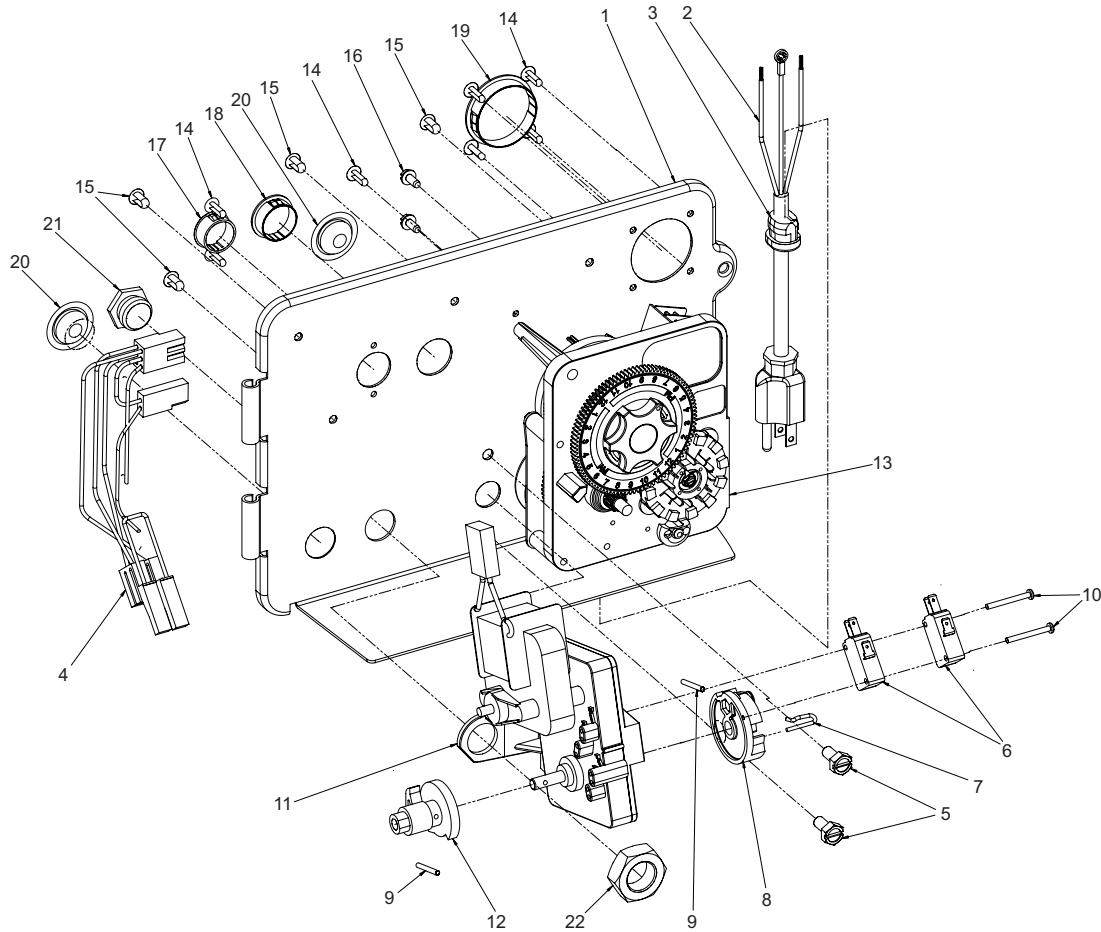

Item No.	Quantity	Part No.	Description
1	1	18697-13	Backplate, Hinged
2	1	11838	Power Cord, 6' Fleck
3	1	13547	Strain Relief, Cord
4	1	40400	Harness, Drive, Designer/Enviromental
5	2	10231	Scrw, Slot Hex, 1/4-20 x 1/2
6	2	10218	Switch, Micro
7	1	10909	Pin, Connecting Rod Spring
8	1	60160-15	Drive Cam Assy, STF, Blue, 2900
9	2	10338	Pin, Roll, 3/32 x 7/8
10	2	14923	Screw, Pan HD Mach, 4-40 x 1
11	1	41543	Motor, Drive, 115V/60HZ
12	1	12777	Cam, Shut-off Valve
13	1	61502-3200	Timer Assy, 3200 Clock
14	7	19800	Plug (Hole Size: Dia .140)
15	4	19801	Plug, Dia .190
16	2	10300	Screw, Hx Wash Head, 8 x 3/8
17	1	15806	Hole Plug, Heyco
18	1	16493	Plug, Hole, Heyco, .88 Dia
19	1	40306	Plug, 1.50 Hole, Dome, Heyco
20	2	19691	Plug, .750 Dia. Hole, Flush
21	1	10712	Fitting, Brine Valve
22	1	10269	Nut, Jam, 3/4-16

2750 CONTROL VALVE

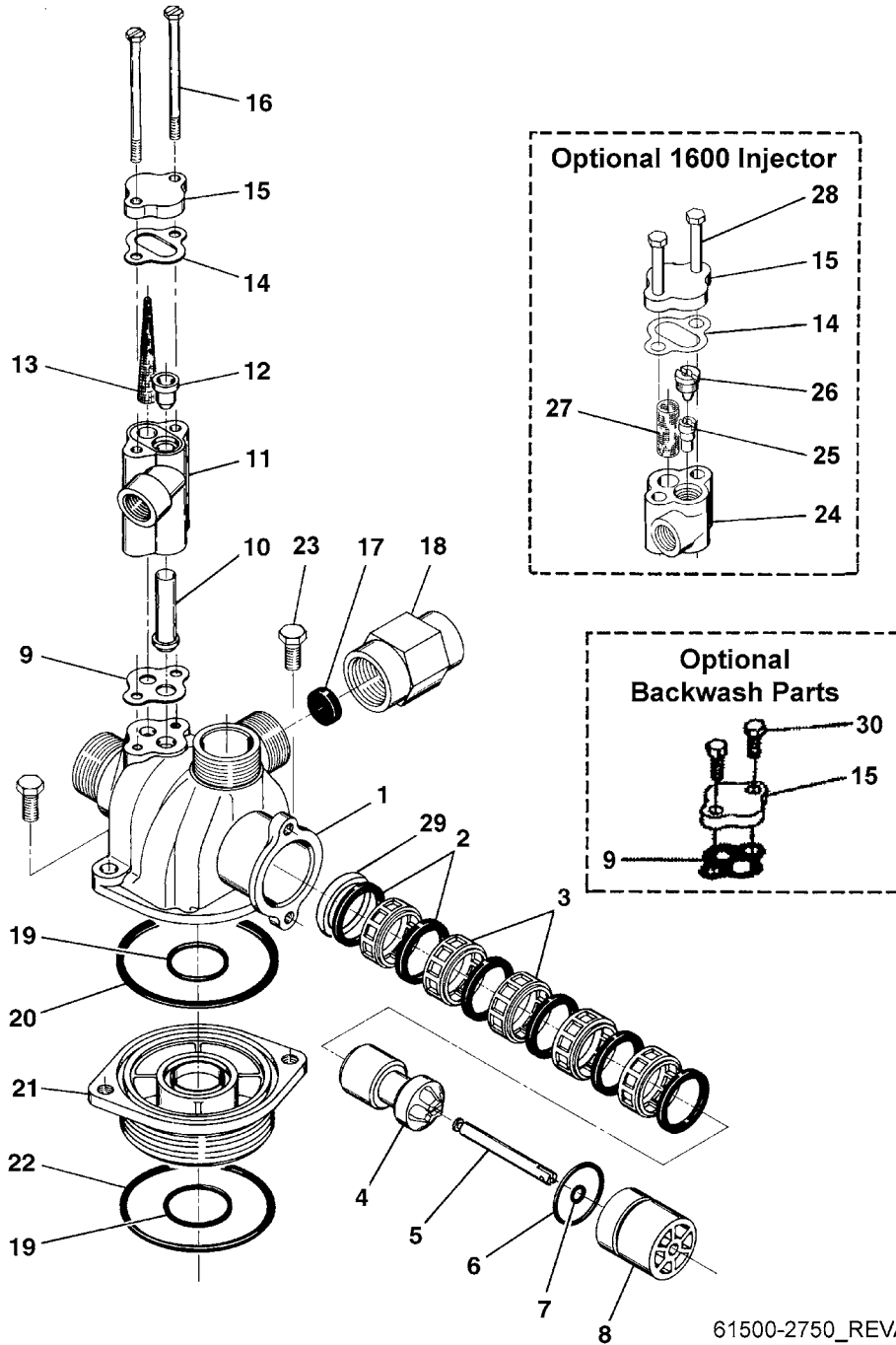

2750 CONTROL VALVE

Item No.	Quantity	Part No.	Description
1.....	1	14749.....	Valve Body, 2750
2.....	6	10545.....	Seal, Piston
3.....	5	11451.....	Spacer, 12 Hole
		16589.....	Spacer, HW
4.....	1	14451.....	Piston, 2750
5.....	1	14452.....	Rod, Piston
6.....	1	10234-01	O-Ring, -024, 560CD
7.....	1	10209.....	Quad Ring, -010
8.....	1	10598.....	End Plug Assembly
		10598-01	End Plug Assembly, Hot Water
9.....	1	14805.....	Gasket, Injector Body, 1600/1700
10.....	1	14802-xxc.....	Throat, Injector, -xxc is for Injector Size
11.....	1	17777.....	Body, Injector, 1700
12.....	1	14801-xxc.....	Nozzle, Injector, -xxc is for Injector Size
13.....	1	14803.....	Screen, Injector
14.....	1	10229.....	Gasket, Injector Cap, 1600
15.....	1	11893.....	Cap, Injector, Stainless Steel
		10228.....	Cap, Injector, Brass
16.....	2	14804.....	Screw, Hex Hd Mach, 10-24 x 2-3/4
17.....	1		Washer - Flow Control (specify size)
18.....	1	60365-00	Housing, DLFC, 1/2"F x 3/4"F
19.....	2	11710.....	O-ring, -215
20.....	1	11208.....	O-ring, -232
21.....	1	12461-01	Adapter Base, 1" 2-1/2" - 8 Quick Connect
22.....	1	10381.....	O-ring, -231
23.....	2	11224.....	Screw, Hex Hd, 5/16 - 18 x 5/8
24.....	1	17776.....	Body, Injector
25.....	1	10914-xx.....	Throat, Injector, -xx is for Injector Size
26.....	1	10913-xx.....	Nozzle, Injector, -xx is for Injector Size
27.....	1	10227.....	Screen, Injector
28.....	2	10692.....	Screw, Slot Hex Hd, 10-24 x 18-8 Stainless Steel
29.....	1	10757.....	Spacer, End
		10757B	Spacer, End, Brass
30.....	1	15137.....	Screw, Hex Wsh Mach, 10-24 x 3/8
Not Shown	1	16221.....	Disperser, Air, 1600
	1	17996.....	Disperser, Air, 1700

SERVICE ASSEMBLIES**ADAPTERS - SIDE MOUNT**

A2285017 Sidemount Adapter Assembly

AUXILIARY MICRO SWITCH

A2203010 3200 Series Timer

COVERS

A2103095 Environmental

A2103043 Designer 1 piece (only available in black)

DRAIN LINE FLOW CONTROLS

60366-__ 1" FNPT x 3/4" FNPT (specify flow control .6 - 7.0)

60701-__ 1" FNPT x 1" FNPT (specify flow control 8.0 - 25.0)

60702-__ 1" FNPT x 1" MNPT (specify flow control 8.0 - 25.0)

60708-__ 1" FNPT x 3/4" FNPT (specify flow control 8.0 - 25.0)

60721-__ 1" FNPT x 1" FNPT (specify flow control .6 - 7.0)

CAM ASSEMBLY

A2300002 Separate time fill drive cam (Black)

PISTON ASSEMBLIES

A2309002 2750/2900 Piston Assy Hard Water By-Pass

A2309003 2750/2900 Piston Assy Hot Water

A2309025 2750 Piston Assy No-Hard Water By-Pass

SEAL & SPACER KITS

A2435025 Seals & Spacers Kit

A2435038 Seals & Spacers Kit - Hot Water

SERVICE EQUIPMENT

A2475001 Seal & Spacer stuffer tool

A2474001 Spacer puller tool

A2423002 Silicone, 2 oz. Tube

SERVICE VALVE OPERATOR ASSEMBLY (SVO)

A2207015 Service Valve Operator Assembly - SVO



TROUBLESHOOTING 2750 VALVE

Problem	Cause	Correction
1. Water conditioner fails to regenerate.	A. Electrical service to unit has been interrupted	A. Assure permanent electrical service (check fuse, plug, pull chain, or switch)
	B. Timer is defective.	B. Replace timer.
	C. Power failure.	C. Reset time of day.
2. Untreated water.	A. By-pass valve is open.	A. Close by-pass valve
	B. Leak at distributor tube.	B. Make sure distributor tube is not cracked. Check O-ring and tube pilot.
	C. Internal valve leak.	C. Replace seals and spacers and/or piston.
3. Loss of water pressure.	A. Iron buildup in line to water conditioner.	A. Clean line to water conditioner.
	B. Iron buildup in water conditioner.	B. Clean control and add mineral cleaner to mineral bed. Increase frequency of regeneration.
	C. Inlet of control plugged due to foreign material broken loose from pipes by recent work done on plumbing system.	C. Remove piston and clean control.
4. Loss of mineral through drain line.	A. Air in water system.	A. Assure that well system has proper air eliminator control. Check for dry well condition.
	B. Improperly sized drain line flow control.	B. Check for proper drain rate.
5. Iron in conditioned water.	A. Fouled mineral bed.	A. Check backwash, brine draw, and brine tank fill. Increase frequency of re-generation. Increase backwash time.
6. Control cycles continuously.	A. Misadjusted, broken, or shorted switch.	A. Determine if switch or timer is faulty and replace it, or replace complete power head.
7. Drain flows continuously.	A. Valve is not programming correctly.	A. Check timer program and positioning of control. Replace power head assembly if not positioning properly
	B. Foreign material in control.	B. Remove power head assembly and inspect bore. Remove foreign material and check control in various regeneration positions.
	C. Internal control leak.	C. Replace seals and piston assembly.

NOTES

NOTES

NOTES



2227 South Street • P.O. Box 044170 • Racine, WI 53404-7003
Ph. (262) 681-1300 • Fax (262) 681-1318 • Info@Marlo-Inc.com • www.Marlo-Inc.com
