



**INSTALLATION, OPERATION,
AND MAINTENANCE MANUAL**

**MR 150–1050M
TWIN SOFTENER
WITH 400C HMI
PLC CONTROLLER
COMMERCIAL
WATER CONDITIONERS**

COMPLETE FOR FUTURE REFERENCE:

MODEL NO:

SERIAL NO:

DATE INSTALLED:

DEALER:

Marlo Incorporated
2227 South Street
P.O. Box 044170
Racine, WI 53404-7003
www.Marlo-Inc.com

IMPORTANT PLEASE READ:

- Warranty of this product extends to manufacturing defects.
- The information, specifications and illustrations in this manual are based on the latest information available at the time of printing. The manufacturer reserves the right to make changes at any time without notice.
- This product should be installed by a plumbing professional on potable water systems only.
- This product must be installed in compliance with all local and state and municipal plumbing and electrical codes. Permits may be required at the time of installation.
- If operating pressure exceeds 100 psi a pressure reducing valve must be installed. If operating pressure drops below 30 psi a booster pump must be installed.
- Do not install the unit where temperatures may drop below 32°F or rise above 100°F.
- A prefilter should be used on installations in which free solids are present.
- A constant voltage of 120V/60Hz (unless otherwise specified) must be supplied to the controller to maintain proper function.
- Union or flange fittings are recommended at the control valve's inlet, outlet, and drain connections
- If distance of drain line is over a 10 ft. vertical or 25 ft. horizontal run, increase drain line one pipe size over that provided on the control valve.
- Do not make a direct connection to the drain. Provide an air gap of at least four times the diameter of the pipe to conform to sanitation codes and to permit observation of the flow.

Please Circle and/or Fill in the Appropriate Data for Future Reference:

Softener Model: MR _____

System Size: Single/Twin/Triple/Quad

Meter Size: _____

Configuration: Timeclock/Twin Alt/Parallel/Progressive

Unit Capacity: _____ Grains

Feed Water Hardness: _____ Grains

Treated Water: _____ Gallons/Liters

BW/Regen Time _____ AM/PM or OFF

Additional Notes: _____

TABLE OF CONTENTS

Water Treatment Product Warranty and Softener Guarantee _____	1
Specification Notes _____	2
Specification Table _____	3
General Arrangement Drawing _____	4

INSTALLATION

Installation Dimensions and Specifications _____	5
General Information _____	6
Piping Installation _____	7
Control Tubing Installation/Diagrams _____	9
Brine Tank Installation _____	10
Softener Loading _____	11

OPERATION

Start Up Instructions _____	12
Electrical Controls Operation _____	13
Batch Calculation and Setting _____	26
Softener General Operation _____	27
MR Softener Flow Diagram _____	28
Brine System Operation _____	29
Minimum Salting Adjustment _____	30
Flow Rate Trip Point Table _____	31
K Factor Table _____	32

MAINTENANCE

Electrical Controls Drawings _____	33
Replacement Valve Table _____	39
Diaphragm Valve Repair Kits _____	40
Signet Flow Sensor _____	41
Brine Assemblies _____	42
Troubleshooting Guides _____	44

Ordering:

Orders may be phoned, faxed, or emailed to Marlo Incorporated. Purchase orders must include Marlo Incorporated part numbers and pricing. Purchase orders must also state if partial shipments are allowed. If you do not hear from the customer regarding the confirmation within 24 hours, we will assume everything is correct and will invoice and ship accordingly.

Order Confirmations:

All purchase orders will be confirmed by phone, fax, or email. Any discrepancies in part numbers, pricing, descriptions, or case quantities will be listed in the order confirmation. It is the customer's responsibility to review the order confirmations and advise if any changes are to be made. If we do not hear from the customer regarding the confirmation within 24 hours, we will assume everything is correct and will invoice and ship accordingly.

Quotes & Prices:

Quotations are valid for a period of up to 45 days or for the term stated on the quote, whichever term is shortest. We make every effort to notify customers with price change information. However, prices are subject to change or correction without notice. Shipping weights, dimensions and anticipated ship dates are all approximate and subject to change.

Minimum Orders:

Minimum order accepted is \$25.00, not including freight or taxes.

Taxes:

Taxes are not included. Quoted prices are exclusive of all taxes. Purchaser shall be responsible for payment of all applicable state/local taxes. Orders shipped within Wisconsin are subject to applicable state tax rates unless a completed resellers card or exempt certificate is on file.

Freight:

All shipments are F.O.B. Marlo Incorporated Racine, Wisconsin, unless otherwise specified.

Shipment:

The shipment method should be specified by the customer on the purchase order; otherwise, Marlo Incorporated will choose the best method of shipment.

Packaging:

Pricing includes packaging that is satisfactory for air, truck, or containerized shipment at no additional cost, unless otherwise stated. Ocean export crating will require an additional charge.

Terms - Domestic Customers:

Terms of payment on open accounts are net 30 days from the date of invoice, unless otherwise stated and mutually agreed upon by both parties. This agreement is subject to credit approval. Terms will only be issued to companies which reside in the United States of America. Orders will not be shipped if any account is past due and/or until payment by check has cleared.

Orders in excess of \$60,000 will require partial payments prior to shipment. A specific progress payment schedule will be stated in the quotation. Partial payments may also be required for orders involving special engineering or custom ordered items regardless of order amount.

Interest will be charged on past due accounts. Interest charges will be calculated on the unpaid balance at 1.5% per month. All questions regarding invoices and terms must be addressed with our accounting department before invoices become due.

Unless specifically included as a separate item, prices quoted do not include any city, county, state or federal taxes, or transportation of merchandise.

Terms - International Customers:

All payments due are in U.S. dollars and must be made in advance by check (must clear before shipment), money orders, wire transfer, or credit card. Credit cards that are accepted are Visa, MasterCard, and American Express. Irrevocable Letters of Credit are accepted with a minimum order of \$25,000.00 U.S. dollars, per order. Unless specifically included as a separate item, prices quoted do not include any city, county, state or federal taxes, or transportation of merchandise. A deposit may be required for special or custom ordered items.

Freight Claims:

Any damage, discrepancies and/or freight claims must be made immediately and directly, in writing within ten (10) days to Marlo Incorporated. Marlo Incorporated will help as much as possible in settling claims. However, Marlo Incorporated will not be held responsible for breakage or shortage after products are accepted by common carrier. All shipments must be inspected for damages and counted for shortages at the time of delivery.

Order Changes:

Additions to an order may be made at no charge prior to the processing of an order. Processing of an order typically begins within one hour of receipt of a purchase order and is typically accomplished within one working day.

Orders cancelled after the order has been processed and sent to shipping or engineering, will be subject to a minimum 10% cancellation fee, assuming manufacturing has not commenced, and no detailed engineering or special parts have been ordered. Additional fees may be charged depending on the level of completion of detailed engineering, manufacturing, and/or if any special parts have been ordered.

Returns & Restocking:

A Return Goods Authorization (RGA) number must be obtained from Marlo Incorporated before any product returns can be accepted and/or replacements shipped. All returns for warranty consideration are to be shipped prepaid and must be returned within ten (10) business days from the RGA issuance. Returns determined to be in warranty will be replaced or repaired and will be returned to Buyer prepaid. Products returned, other than valid warranty claims, may be subject to a restocking charge of up to 25%. Orders shipped incorrectly by Marlo Incorporated are not subject to restocking charges and correct items will be shipped to Buyer prepaid.

Excusable Delays:

Marlo Incorporated shall not be in default for failure to deliver or delay in delivery arising out of causes beyond its control and without its negligence, including but not limited to Acts of God or the public enemy; acts of the Government in either its sovereign or contractual capacity; fires; floods; epidemics; quarantine restrictions; strikes; shortages of materials or supplies; labor disputes; freight embargoes; delays in transit; consignments lost or damaged by freight agent(s); and unusually severe weather.

Warranty:

Marlo Incorporated warrants its products to be free from defects in design, material, or workmanship for a period of 18 months from shipment date or 12 months from installation, whichever occurs first, when said products are installed and operated in accordance with the written instructions provided. The fiberglass reinforced polyester (FRP) resin/media tanks used in certain products alone have an extended warranty period of five (5) years from the shipment date. If within that period any products shall be proven to Marlo, Inc.'s satisfaction to be defective, those products will be replaced, or the price refunded at Marlo Inc.'s option. Marlo Inc.'s obligations or nonperformance, defective, or any damage caused by its products or their use, and buyer's exclusive remedy therefore, shall be limited to product replacement or refund and shall be conditioned upon Marlo Inc.'s receiving written notice together with a demand for such replacement or refund:

The foregoing warranty is exclusive and in lieu of all other expressed implied warranty (except of title) including but not limited to implied warranty of merchantability and fitness for particular purpose.

Marlo Inc. will not be subject to and disclaims the following:

1. Any other obligations or liabilities arising out of breach of contract or out of warranty.
2. Any obligations whatsoever arising from tort claims (including negligence and strict liability) or arising under other theories of law with respect to products sold or services rendered by Marlo Inc. or any undertakings, acts, or omissions relating thereto.
3. All consequential, incidental, and contingent damages including labor charges, back charges or handling charges are excluded from Marlo Inc.'s warranty provisions.

Policy:

These terms and conditions may be superseded by specific provisions provided by Marlo Incorporated. However, should any of these terms and conditions be contrary to or inconsistent with any terms and conditions contained in any purchase order form or other document between Marlo Incorporated and the buyer, which is prepared by the buyer and whenever executed, the provisions hereof shall be controlling and shall supersede the conflicting terms and conditions which are contained in such other document. No changes shall be made to our terms and conditions unless prior written authorization by Marlo Incorporated

SPECIFICATION NOTES

Maximum salting is 15 pounds of salt per cubic foot of resin. This setting gives the longest time between regenerations. It has an efficiency of 2,000 grains of hardness removed per pound of salt. The Brine tank and Regeneration timer are setup for maximum salting at the factory.

Minimum salting is 6 pounds of salt per cubic foot of resin. It has an efficiency of 3,300 grains of hardness removed per pound of salt.

Freeboard is the distance between the surface of the resin and the top side shell of the tank.

On continuous flow rates pressure loss does not exceed 15 psig.

On peak flow rates pressure loss does not exceed 25 psig.

Minimum operating pressure is 30 psi.

Maximum operating pressure is 100 psi.

Standard units are designed to soften unheated water in the range is 35-100°F.

Power requirements are 120 Volt, 60 Hertz, Single Phase, 2 amps

Salt specifications are pelletized or solar salt, 99% pure, containing less than 1% insolubles.

The Pinwheel Setting time intervals are adjustable.

SPECIFICATION TABLE

MODEL		MR	150				210				300				450				600				750				900				1050			
Valve Size		inches	1	1 ¼	1 ½	2	1 ¼	1 ½	2	2 ½	1 ½	2	2 ½	3	1 ½	2	2 ½	3	1 ½	2	2 ½	3	2	2 ½	3	2	2 ½	3	2	2 ½	3			
Capacity (Kgrains)		Max	150				210				300				450				600				750				900				1050			
		Min	100				140				200				300				400				500				600				700			
FLOW RATE (GPM)	Service	Cont's.	32	42	45	57	41	64	80	115	68	92	140	165	63	82	120	140	72	110	140	175	90	140	160	90	140	160	105	150	188	95	135	173
		Peak	55	78	69	97	57	86	110	160	92	125	190	230	90	115	170	190	94	125	190	250	116	190	230	116	190	230	133	218	279	124	210	259
	Backwash & Flush	10				15				20				20				30				30				45				45				
	Brine Draw & Rinse	2.5				3.5				5				5				7				7				10				10				
TIMER PINWHEEL SETTINGS	Backwash	Pins	5				5				5				5				5				5				5							
		Minutes	10				10				10				10				10				10				10							
	Brine Draw & Rinse	Pins	30				30				30				30				30				30				30							
		Minutes	60				60				60				60				60				60				60							
	Fast Flush	Pins	3				3				3				3				3				3				3							
		Minutes	6				6				6				6				6				6				6							
	Return to Service	Pins	2				2				2				2				2				2				2							
		Minutes	4				4				4				4				4				4				4							
SOFTENER TANK	Size	Dia x Ht Inches	20x54				24x54				30x54				30x60				36x60				36x72				42x60				42x72			
	Gravel Subfill	Pounds	100				200				300				300				400				400				600				600			
	Resin	Cubic Feet	5				7				10				15				20				25				30				35			
	Freeboard	Inches	23½				24				26½				20				23				26½				19½				25			
BRINE SYSTEM	Tank Size	Dia x Ht Inches	24X50				24x50				24x60				30x60				39x60				39x60				42x60				50x60			
	Injector	Code	2.0-050				3.5-075				5.0-075				5.0-075				7.0-100				7.0-100				10.0-100				10.0-100			
		Color	Red				White				Blue				Blue				Red				Red				White				White			
	Max Salt Storage	Pounds	700				600				600				1000				1900				1700				1900				2300			
	Salt Dosage	Max.	75				105				150				225				300				375				450				525			
		Min.	30				42				60				90				120				150				180				210			
	Regens per Salt Refill	Max.	9				5				4				4				6				4				4				4			
		Min.	23				14				10				11				15				11				10				10			
Brine Valve Float Height	Max.	12				19				26				26				19				26				26				19				
	Min.	3				8				9				9				8				9				9				8				

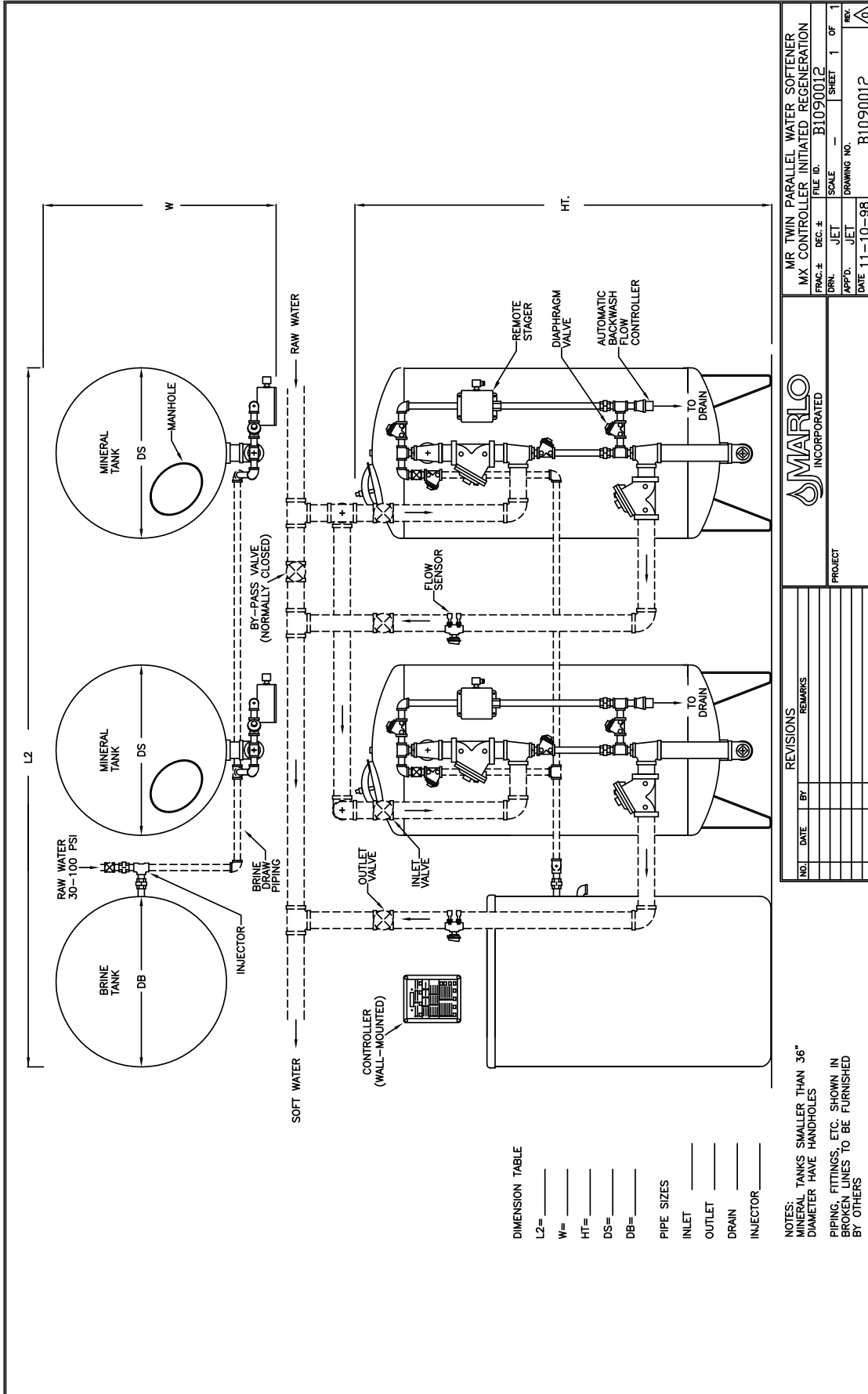

DIMENSION TABLE

- L2= _____
 W= _____
 HT= _____
 DS= _____
 DB= _____
PIPE SIZES
 INLET _____
 OUTLET _____
 DRAIN _____
 INJECTOR _____

NOTES: TANKS SMALLER THAN 36" DIAMETER HAVE HANDHOLES
 PIPING, FITTINGS, ETC. SHOWN IN
 BROKEN LINES TO BE FURNISHED
 BY OTHERS

MR TWIN PARALLEL WATER SOFTENER MX CONTROLLER INITIATED REGENERATION			
FRAC. #	DEC. #	FILE ID.	B1090012
DRN.	JET	SCALE	SHEET 1 OF 1
APP'D.	JET	DRAWING NO.	B1090012
DATE	11-10-98		

MARLO INCORPORATED	
PROJECT	

REVISIONS		REMARKS
NO.	DATE	BY

INSTALLATION DIMENSIONS AND SPECIFICATIONS

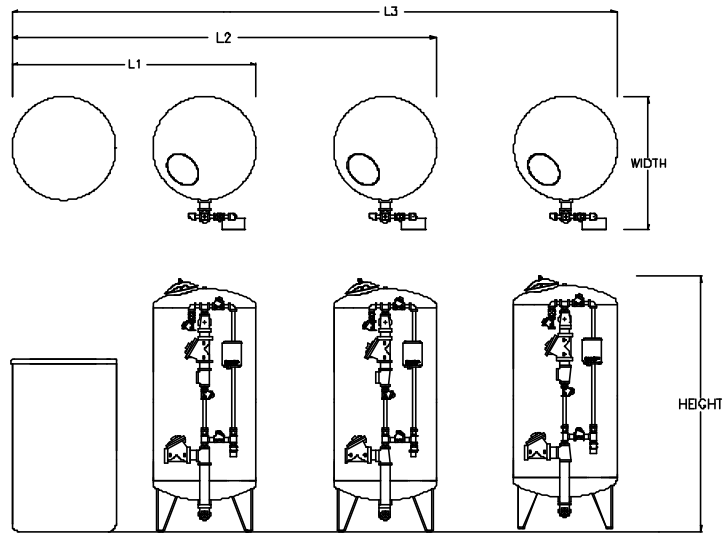

MODEL	Approx. Height (inches)	Length			Width (Inches)	Brine Pipe Size (inches)	Drain Pipe Size (inches)	Pipe Size (inches)
		L1 Single	L2 Twin	L3 Triple				
MR-150-1	72	50	88	126	29	3/4	1	1
MR-150-1¼					30			1¼
MR-150-1½					30			1½
MR-150-2					34			2
MR-210-1¼	73	54	96	138	32	3/4	1¼	1¼
MR-210-1½					32			1½
MR-210-2					36			2
MR-210-2½					37			2½
MR-300-1½	76	60	108	156	38	3/4	1¼	1½
MR-300-2					42			2
MR-300-2½					43			2½
MR-300-3					44			3
MR-450-1½	82	66	114	162	38	3/4	1¼	1½
MR-450-2					42			2
MR-450-2½					43			2½
MR-450-3					44			3
MR-600-1½	89	81	135	189	44	1	1½	1½
MR-600-2					48			2
MR-600-2½					49			2½
MR-600-3					50			3
MR-750-2	101	81	135	189	48	1	1½	2
MR-750-2½					49			2½
MR-750-3					50			3
MR-900-2	94	90	150	218	54	1	2½	2
MR-900-2½					55			2½
MR-900-3					56			3
MR-1050-2	106	98	158	218	54	1	2½	2
MR-1050-2½					55			2½
MR-1500-3					56			2½

*When less than 4 hours is expected between regeneration's of a twin or triple softener, a brine tank for each softener is required.

SOFTENER INSTALLATION INSTRUCTIONS

GENERAL INFORMATION

Before beginning installation, thoroughly review the following instructions to familiarize yourself with the general placement and identification of all components.

These instructions are written for a single unit installation, but they also generally apply to twin and triple units. Refer to specific equipment layout drawing, water meter installation instruction, and interconnecting electrical wiring diagram for your system.

Minimum operating pressure is 30 psi.
If pressure less than 30 psi is encountered, a pump must be installed.

Maximum operating pressure is 100 psi.
If pressure greater than 100 psi is encountered, a pressure regulator must be installed.

Power requirements are shown on electrical wiring diagram.

Standard units are designed to soften unheated water in the range is 35-100°F.
Special valve assemblies are available to handle heated water supplies exceeding 100°F.
Consult factory if applicable.

Catalog softeners are shipped fully assembled with face piping and controllers. Care must be taken not to damage valves or controllers during uncrating and installation.

During unpacking the brine tank miscellaneous parts are shipped inside the brine tank. These parts include hardness test kit, injectors, extra manuals and other parts that may apply to your particular system. Care should be taken when unpacking the brine tank.

SOFTENER LOCATION

1. Select a position near a floor drain that has adequate carrying capacity to handle the water softener backwash rate. See the Specification Table for the backwash rate of your system.
2. Refer to your specific equipment layout drawing located on page 31 for tank locations. The approximate dimensions required for your particular system is shown on page 4. Make sure the softeners are placed on a level concrete surface.

PIPING INSTALLATION

Note:

- Install the piping conforming to federal, provincial, and local codes.
 - Union or flanges are recommended at the control valve's inlet, outlet, and drain connections
 - To enhance the monitoring of the system's performance sample valves and pressure gauges can be installed at the inlet and outlet piping to each control valve.
 - If distance of drain line is over a 10 ft. vertical or 25 ft. horizontal run, increase drain line one pipe size over that provided on the control valve.
 - Do not make a direct connection to the drain. Provide an air gap of at least four times the diameter of the pipe to conform to sanitation codes and to permit observation of the flow.
 - It is not recommended that an overhead or a long horizontal drain run be used. The increase of backpressure will cause problems when drawing brine.
1. Install piping as shown on the layout drawing located on page 31. Include unions and shut-off valves on the inlet and outlet of each softener. Also, include a shut-off valve for each injector provided with the system. It is recommended that a union be installed in each softener drain-line to facilitate cleaning the backwash flow control.

Note: Do **not** reduce drain-line pipe size. Do **not** install a shut off valve in the drain-line. Provide an air gap in the drain line in accordance with local codes (minimum four (4) pipe diameters).

2. If your system has a water meter thoroughly read the meter instructions manual located in the back of this manual before installing any water meters or flow sensors,. Water meters typically must be installed in a particular manner (i.e. horizontal, plane or with recommend pipe lengths) to function properly.
3. After the piping has been completed, make sure to close all isolation valves.

TUBING DIAGRAM - VALVE NEST - MULTITANK - ASCO SOLENOID

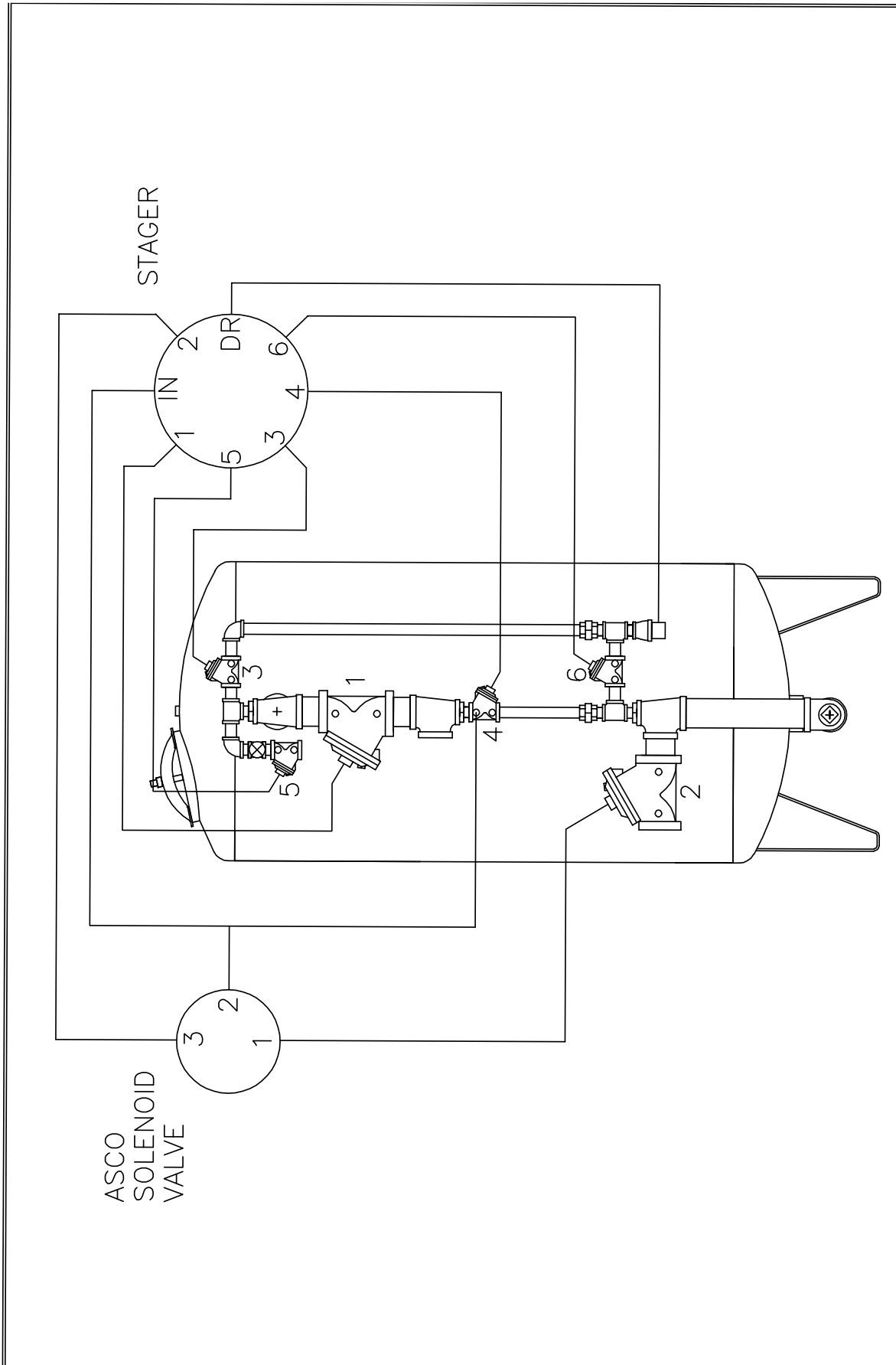

REVISIONS		CONTROL TUBING DIAGRAM MR WITH SOLENOID OVERRIDE			
NO.	DATE	BY	REMARKS	FILE ID.	SHEET 1 OF 1
1	10APR19	MR	ADD SOLENOID MANUFACTURE NAME	A2006010	1
				SCALE N/A	1
				DRN. BCD	REV. A
				APP'D. BCD	DRAWING NO. A2006010
				DATE 4-24-95	

MULTITANK W/MX OPTION

BRINE TANK INSTALLATION

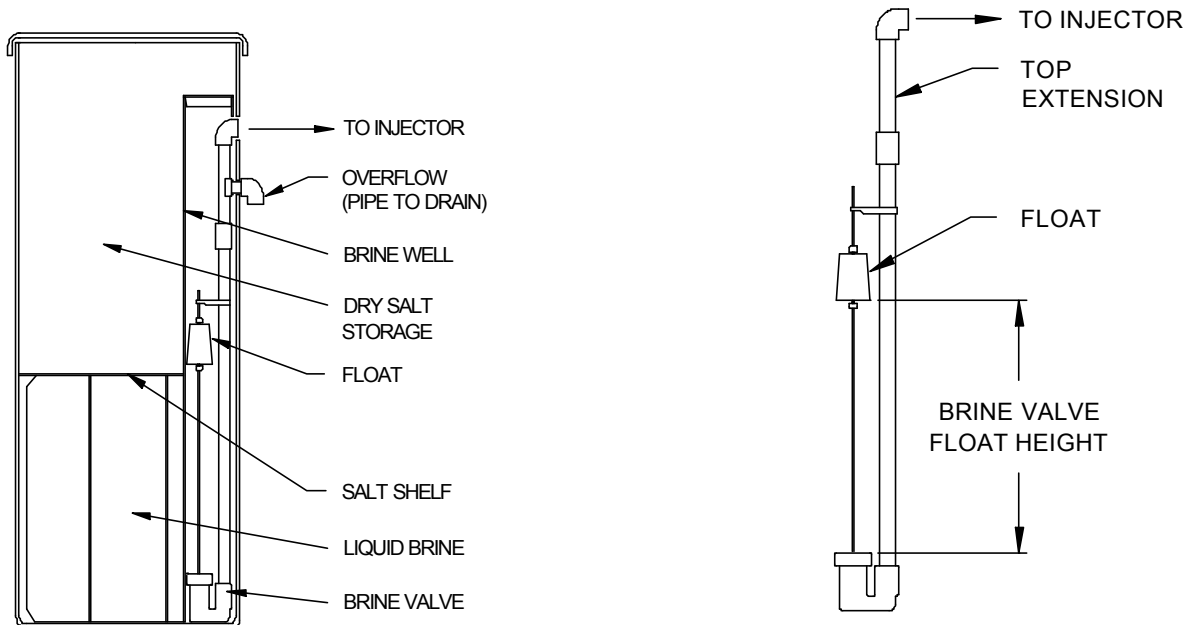

1. The brine tank is placed as shown on the installation drawing, on a smooth level surface. If not, the tank should be placed on a smooth piece of exterior plywood and leveled by placing shims beneath the plywood.
2. Make sure that the salt shelf inside the tank is level and that the brine well is near to vertical as possible. Check the specifications table and make sure that the float setting is the proper height for the model provided. Brine tanks are shipped with the float set for maximum salting. If incorrect, slide the float to the proper setting. Float should be one inch above grid plate.
3. Place brine valve into the brine well and set at the bottom of the brine tank.

Note: If minimum brine draw is desired, remove the pipe nipple and coupling from the brine assembly. Install remaining brine valve assembly into elbow using Teflon tape or Teflon paste, and set float to minimum salt level see Specification Table on page 3 for settings. Place brine valve into brine well. Brine valve assembly will not sit on bottom of brine tank.

4. Connect the brine valve to the brine injector.
5. Open the injector feed water valve and allow the brine tank to fill with water. To speed this process the tank can be filled with hose to about 2" below the platform. The tank will continue to fill until the float rises and shuts off the flow (approximately 1" above the platform).

Note: In the process of making brine for the first regeneration, the solution volume will increase (one gallon of water will be 1.2 gallons of brine). The final level of the liquid will be several inches above the platform.

6. If the refill water shuts off below the platform or too far above the platform, the brine valve should be removed and the float adjusted up or down until it shuts off approximately 1" above the platform. Place the brine well cap seal in place and open the manual valve in the brine line to the softener tank.

SOFTENER TANK LOADING

GRAVEL LOADING

1. See the Specification Table on page 3 for the correct amount of gravel and resin. Do **not** begin loading until you have confirmed all of the required media is on site.
2. Before loading, visually check the lower distributor for shipping damage. All radial arms and baskets strainers are in place and pointing downward. Tighten any loose laterals. Do **not** load tank if there is damage is evident. Call the factory if any damage is observed.
3. Slowly open the inlet valve and fill the tank half way or as full as possible with water. There might be a flow of water to drain.
4. The equipment provided has a plastic lower distributor system. Care should be exercised in the loading of the gravel in order to insure that the distributors are not damaged.
5. Slowly and gently pour the gravel marked for the mineral tank into the unit.
6. Drain the tank down until the gravel and water levels are the same.
7. Carefully level the gravel before loading the resin.

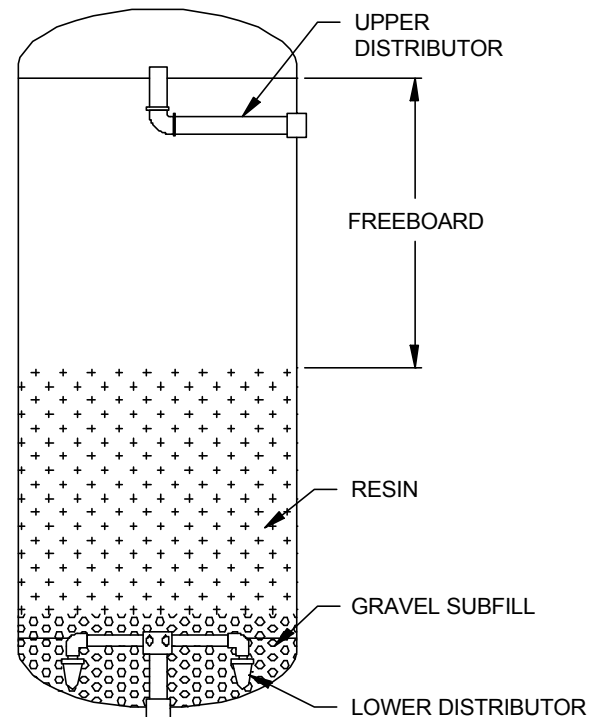

RESIN LOADING

1. Reopen the inlet valve and fill the tank to 1/3 to 1/2 full of water.
2. Pour the quantity of resin marked for the tank in through the top opening.
3. Reopen the inlet valve and fill the tank with water to the top access opening. Close and secure the top access opening.
4. Open inlet valve and continue to fill the tank with water until it is fully pressurized.

START-UP INSTRUCTIONS

PLC PROGRESSIVE CONTROLLER

Note: Read the controls description section located in this manual before proceeding.

With all piping and installation complete, and the mineral in the tank, proceed as follow:

1. Open the manual by-pass valve. The manual inlet and outlet valves are to remain closed.
2. Connect the power to the PLC controller. This operator interface display will light up. Advance the operator interface to the **Main Screen**.
3. Open the remote stager enclosure cover on Unit 1 and manually rotate the stager to the #1 (backwash) position. The stager motor will rotate back to the #4 (service) position. This is done to confirm the controller's homing signal is operational.
4. Manually advance the operator interface to the **Presets Screen**. Verify the cycle time and K factor are correct for your unit size. Change if required.
5. Manually advance the operator interface to the **Flow Rate Presets for Progressive Flow**. Verify the flow presets are correct for your unit using the flow chart in this manual. Change if required.
6. Manually advance the operator interface to the **Operator Control 1 Manually Start/Advance Regeneration**.

7. Advance Unit 1 to the backwash step. The unit 1 stager should rotate to the step 1 (backwash) position.
8. Slowly open the manual inlet supply valve. Do not open fully. Full flow of water could cause loss of media. Continue to fill slowly until all air is expelled and only water flows to the drain. Water will enter from the bottom of the resin tank as air is expelled from the top drain. If the system is supplied with an air vent make sure that the valve is open during this process.
9. When only water flows to the drain and out the air vent (if applicable), open the manual inlet valve all of the way. Backwash until the water looks clean when caught in a container.
10. Advance Unit 1 to the brine/slow rinse step. The Unit 1 stager should rotate to the step 2 brine/slow rinse position. There will be a slow flow to the drain.
11. While the Unit 1 is in the Brine/Slow Rinse position, check the level in the brine tank. The level should be dropping at a slow rate (approximately 2" per minute).
12. Advance Unit 1 to the Fast Rinse position. The Unit 1 stager should rotate to the step 3 (Fast rinse) position. There will be a high flow of water to the drain. Allow the water to flow to the drain until clear. During this time, the brine tank will fill with water until the float closes the brine tank valve. Check that all brine fittings are tight and that the water level in the brine tank is according to the unit specifications.
13. Advance Unit 1 to the service position. The unit 1 stager should rotate to the step 4 Service position. There will be no flow of water to the drain.
14. Perform steps 3-13 to the other units.

15. Fill the brine tank with the proper amount and type of salt recommended for use with the system. See RECOMMENDED TYPES OF SALT.

16. Close the manual by-pass valve and open all outlet valves fully. The system is now in service.

TWIN ALTERNATING SOFTENER ELECTRICAL CONTROLS OPERATION

General-the main control panel (MCP) contains the programmable logic Controller (PLC) and the operator interface (OIT). The system is controlled by the PLC. Operator intervention and control along with some program setpoint access is through the oit. The plc controls the system so that one unit will be online (in service) while the other unit is in standby or regeneration. Normally a unit will start regeneration automatically after its gallon counter counts down to zero from the preset batch. A unit can also be manually forced into regeneration by using a pushbutton on the OIT. A regeneration lockout is built into the logic so that only one unit can be in regeneration at a time.

Note:

Follow all applicable codes and regulations when wiring in this system.

Caution:

Verify all power is disconnected before servicing the equipment

Interconnect wiring-

Power-wire a single phase 120volt, 60 Hz, 15 amp fused circuit to mcp terminals "L", "N", and "G". This power supply should be surge protected.

Do not run high voltage lines near the low voltage input wires on terminal TB2.

OPERATOR INTERFACE SCREENS-LOCATED ON THE FRONT OF THE MCP IS THE OPERATOR INTERFACE (OIT). IT ALLOWS OPERATOR MONITORING AND ACCESS TO THE PROGRAM.

Summary

Screen 1- MAIN SCREEN FOR STATUS INDICATION

Screen 2- REGENERATION START/ADVANCE

Screen 3- PRESETS 1 (CYCLE TIMES), BATCH & KFACTOR

Screen 4- TOTALIZER

Screen 5- SYSTEM RESET/PV CONFIG

Screen 6- SCREEN CHANGES

Notes:

1. None of the screens are secured.
2. Regeneration is frequently abbreviated as regn or regen on the screens.
3. Numeric entry button- all numeric entry button have a red border with a yellow background. The number displayed is the current value for that preset. If a change in data is necessary, touch the desired button on the screen. A small keypad will pop up. Enter in the desired value using this keypad. Press the enter key. (long arrow key) there is a minimum and maximum value that can be entered. If the value entered is out of range a small banner will pop up indicating this.
4. Screen change button - when this button is pressed it will bring up the screen changes screen.

**OPERATOR INTERFACE SCREENS
SCREEN 1-MAIN SCREEN**

The main screen displays the following:

MODE-each units mode is displayed near the upper part of the screen. The modes indicate which cycle the unit is in these can be any one of the following:

- SERVICE
- STANDBY
- BACKWASH
- BRINE/SLOW RINSE
- FAST RINSE

FLOW (RATE)-the unit in service flow rate is shown here in gallons per minute (GPM)

BATCH LEFT-the unit in service gallons remaining in the batch is displayed here. This display counts the gallons down from the preset to zero.

CYCLE TIME- the text “cycle time” and remaining time in the cycle is shown when a unit is in regeneration.

When done changing screens always return to the main screen for display.

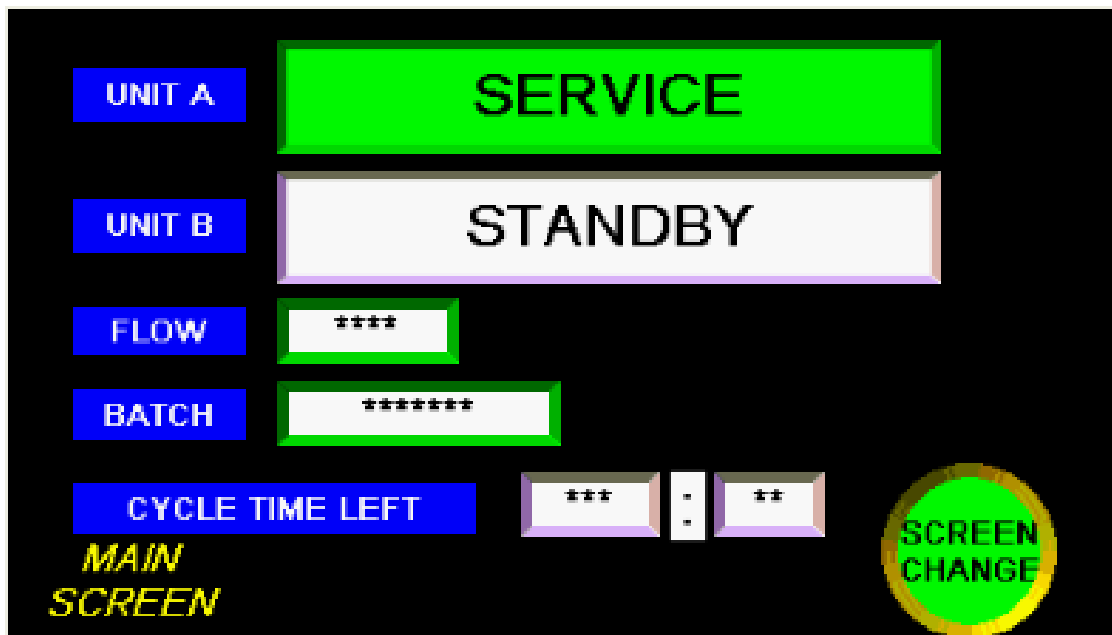

**CONTROLS CONTINUED:
OPERATOR INTERFACE SCREENS
SCREEN 2 REGENERATION START/ADVANCE-OPERATOR CONTROL 1**

This is the main screen used for manual operator regeneration start and advance. It is mainly used to manually start and advance a unit through its regeneration steps. Once a manual regeneration start is begun, regeneration cycle timing is automatic and the unit will advance automatically through the regeneration steps.

Along the top row are two buttons. These allow the operator to manually start a regeneration on any of the units. Once in regeneration this button also allows the operator to manually advance the unit to its next regeneration cycle. Only one unit can be sent into regeneration at a time.

There is a 3 second delay on these buttons to verify operator intent.

If another unit is currently in regeneration the program will not allow another unit to be manually sent into regeneration via its button. There is no memory of this button being depressed if another unit is already in regeneration.

Screen change button - when this button is pressed it will bring up the screen changes screen.

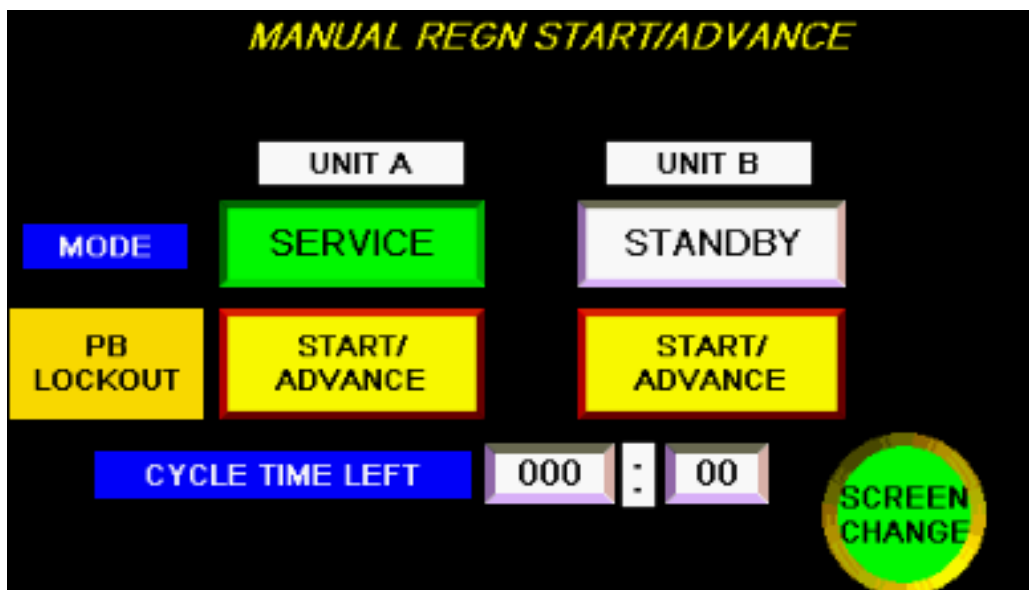

**CONTROLS CONTINUED:
OPERATOR INTERFACE SCREENS
SCREEN 3 PRESETS 1 SCREEN**

This screen can be used to change the following setpoints:

BACKWASH CYCLE TIME IN MINUTES
BRINE SLOW RINSE TIME IN MINUTES
FAST RINSE TIME IN MINUTES
BATCH IN GALLONS
KFACTOR

The initial optimal setpoints for cycle times were entered in at the factory and shouldn't need to be changed. These setpoints are displayed on this screen. The batch setpoint will have to be field entered depending on the water hardness.

Initial setpoints were as follows:

BACKWASH CYCLE TIME IN MINUTES=12
BRINE SLOW RINSE TIME IN MINUTES=60
FAST RINSE TIME IN MINUTES=6
BATCH=10000
KFACTOR = 23.22

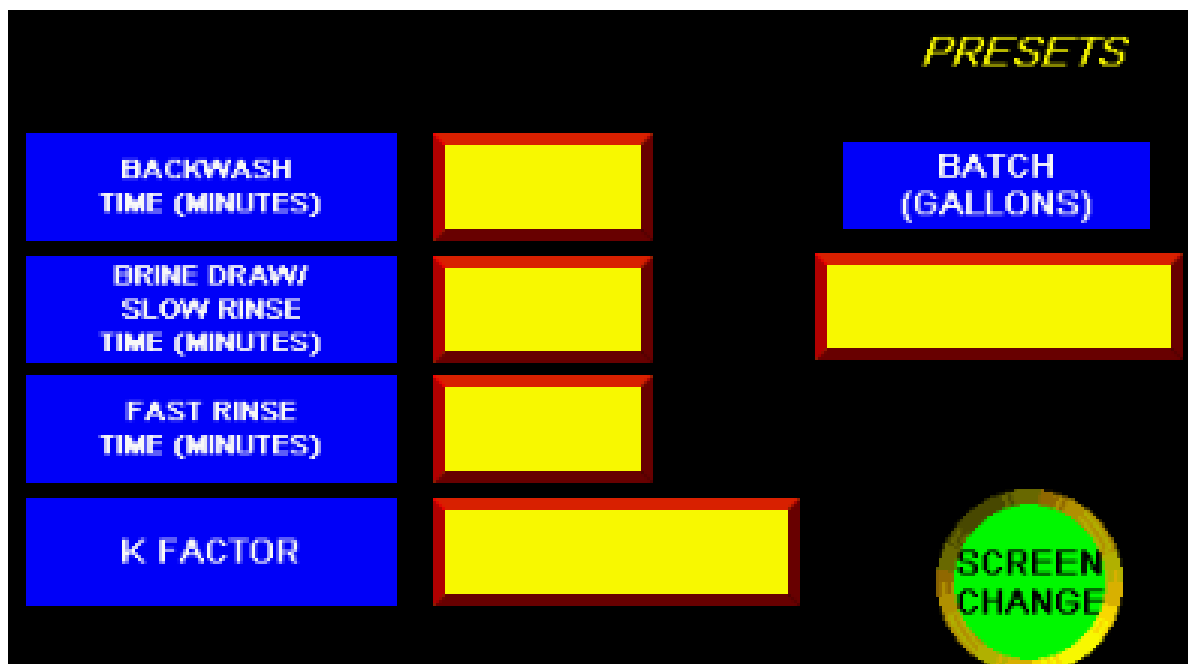

**CONTROLS CONTINUED:
OPERATOR INTERFACE SCREENS
SCREEN 4 OPERATOR CONTROL 2**

This screen allows the system to be reset or allows access to the configuration of the OIT.

SYSTEM RESET-this button when depressed for a minimum of 5 continuous seconds will reset the system. This will take any unit that is currently in regeneration out of regeneration to service or standby.

Unit A will be put in service, B in standby.

CONFIG ACCESS- this allows the operator to go to the OIT configuration menu. This has already been preset and access to this should not be necessary.

Screen change button - when this button is pressed it will bring up the screen changes screen.

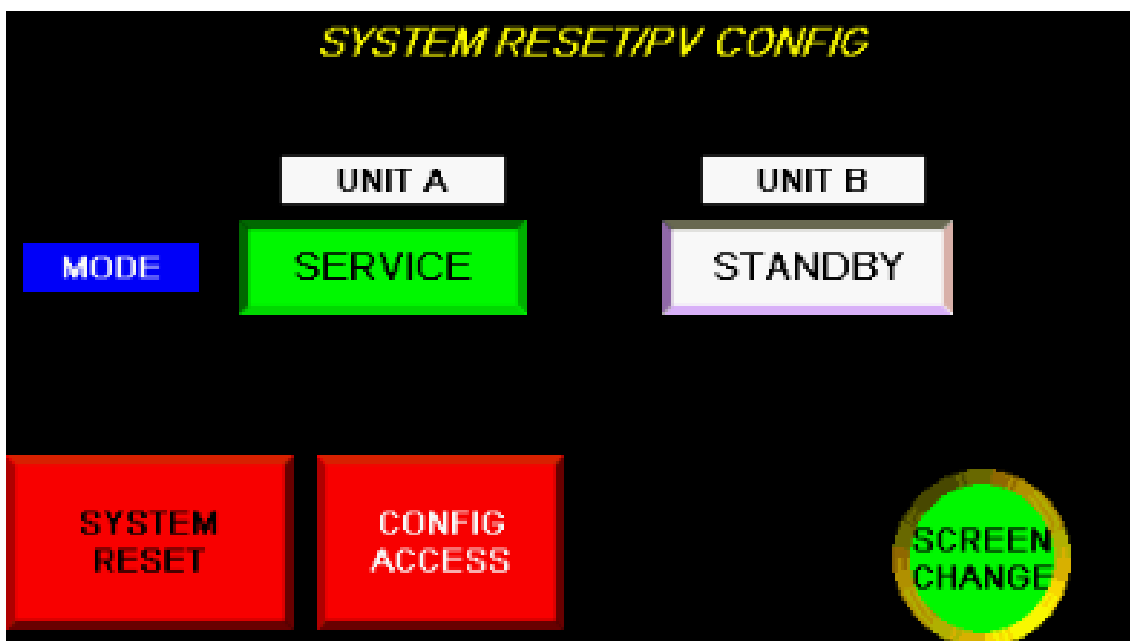

**CONTROLS CONTINUED:
OPERATOR INTERFACE SCREENS
SCREEN 5 SYSTEM TOTALIZER**

This screen is used to view the number of gallons have passed for both units while they were in service.

To reset the totalizer press the button at the bottom of the screen.

-There is a 3 second delay on the totalizer reset button to verify operator intent.

Screen change button - when this button is pressed it will bring up the screen changes screen.



**CONTROLS CONTINUED:
OPERATOR INTERFACE SCREENS
SCREEN 6 SCREEN CHANGES**

This screen can be used to change to a different screen. On some Screens there are shortcuts to often used screens using a function key. This screen allows the user to scroll through the list of screens and choose which one they want.

Use the up/down arrow keys to scroll through the list. Press enter when the cursor is on the desired screen.

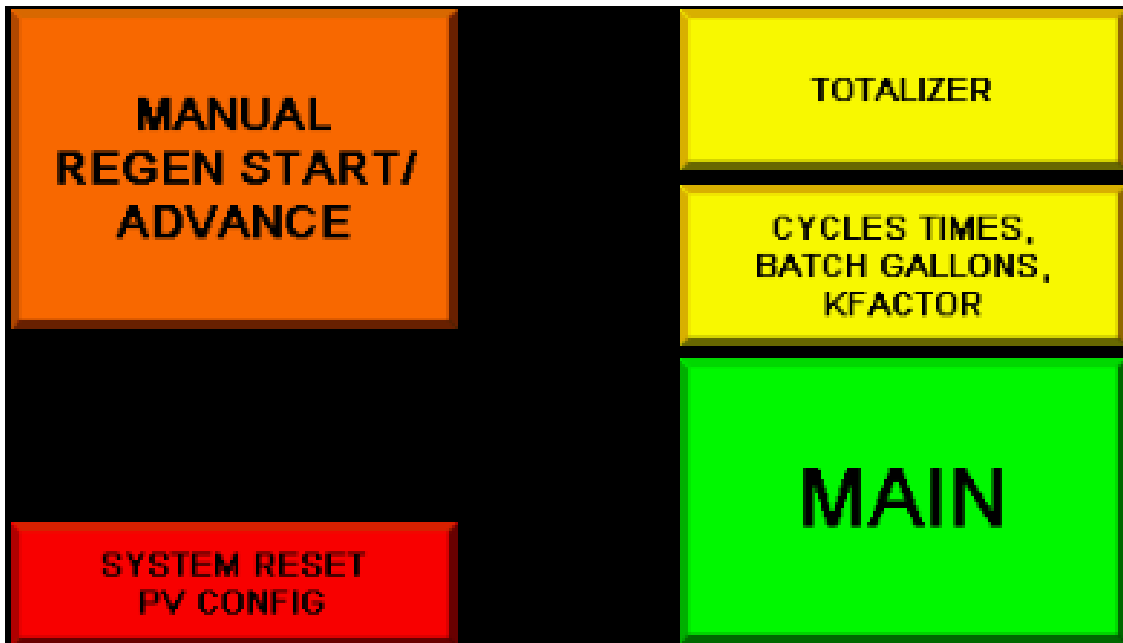

**CONTROLS CONTINUED:
OPERATOR INTERFACE SCREENS
ALARMS: TRIGGERS/BANNERS**

Alarms – this system will alarm under two conditions

- 1) If unit a stager does not return home for any reason.
- 2) If unit b stager does not return home for any reason.

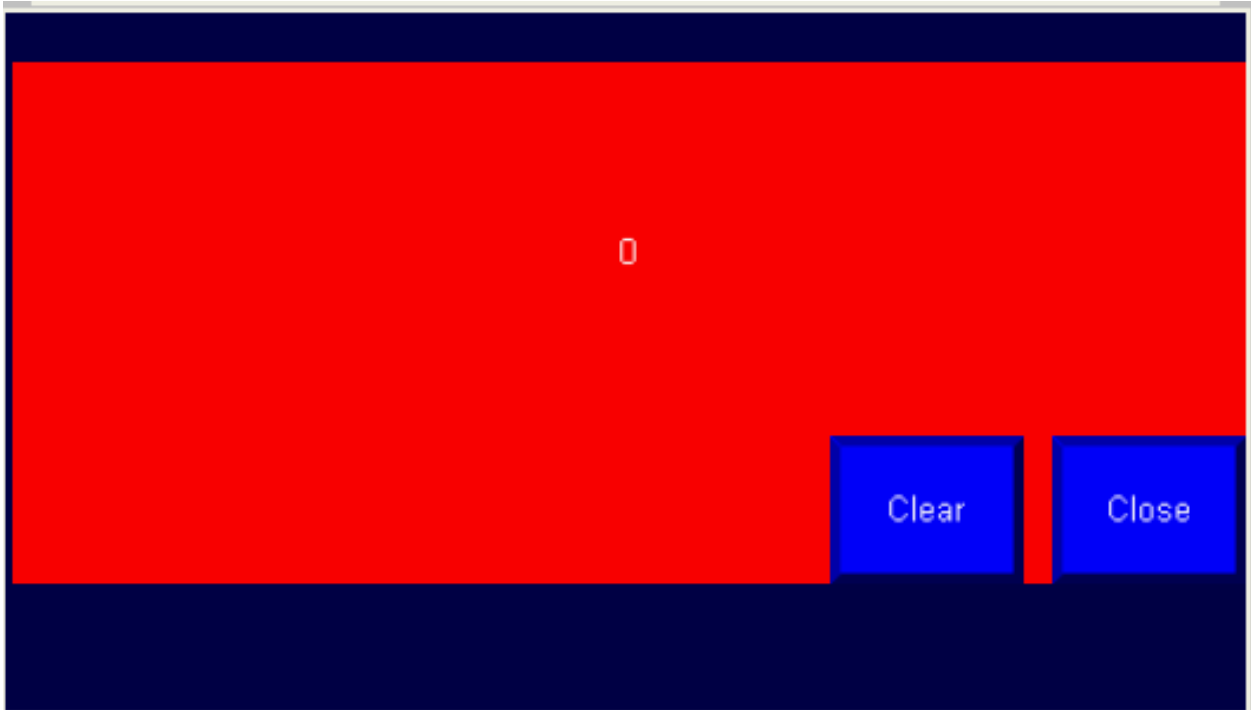

**CONTROLS CONTINUED:
OPERATOR INTERFACE SCREENS**

Screen Saver- after 10 minutes of no activity on the screen, the screen will go blank. This is the screen saver. Press any key on the OIT and the screens will come back on.

Plc memory-

The memory of the plc is protected by flash memory and does not require battery backup when power is removed.

Power loss-

If power is lost and then it comes back on again the controller will remember where it was and continue on where it last was.

Controls continued Miscellaneous

Plc memory-

The memory of the plc is protected by flash memory and does not require battery backup when power is removed.

Power loss-

If power is lost and then it comes back on again the controller will remember where it was and continue on where it last was.

Stager operation-

Each stager is located in its own enclosure on the individual units themselves. They operate the diaphragm vales on the unit. The stager has multiple ports on it to pressurize and vent diaphragm valves in order to open and close them. Pressure to a valve opens the valve. A vent to a valve allows the valve to open. The stager has 4 numbers on its indexing wheel inside of the enclosure. Each position represents a different regeneration cycle. 4= service/standby, 1= backwash, 2= brine/slow rinse, 3= fast rinse. If for some reason power is disrupted the stager can be manually rotated to the different positions in order to manually regenerate the unit. Stager homing- if for some reason the stager gets out of sync with the plc, the plc will drive the stager back to its service #4 position. This can occur if someone manually rotates the stager out of service while there is power to the unit. This is designed to correct the situation if someone happens to tamper with the stagers.

HOW TO CALCULATE SOFTENERS CAPACITY

“Batch size” is the term used for the amount of water passing through and being softened by the water softener between regenerations. This is a simple calculation provided two pieces of information are known:

- Size of the water softener in grains (gr.) (i.e. MR-300 has 300,000 grains capacity per tank).
- Hardness of the raw water being treated by the water softener.

BATCH SIZE EQUATION

Grain capacity of softener divided by the grains of hardness equals batch size.

SAMPLE CALCULATION

Assume: unit is a MR-300-2

Assume: the hardness of the water was measured to be 20 grains

Using our equation take $300,000 \div 20 = 15,000$ gallons.

10% reserve capacity = 1500 gallons.

$15,000 \text{ gallons} - 1500 \text{ gallons} = 13,500 \text{ gallons (batch size)}$

For immediate regeneration type meter control the meter setting would be at 15,000 gallons. Commonly this value is adjusted to 90 percent of the actual value (in this example 13,500 gallons) to assure not over-running the softener.

For time delay type meters the amount of gallons is determined as in our example except an additional amount of gallons must be deducted from the actual gallons to allow soft water to be available until the softener regenerates at the selected delay time of day or night. This compensation is necessary since the meter will indicate regeneration-required time prior to the set delay time.

WATER SOFTENER GENERAL OPERATION

Hard water passes through the valve manifold into the top of the softener tank. It flows downward through the mineral bed and out through the bottom of the tank to service. As the water passes through the mineral bed, the hardness present is removed through the process of ion exchange and at the same time sediment present is removed by filtration action of the mineral.

Once the mineral has extracted all the hardness it can, it must be regenerated and have its capacity restored by the following procedure:

- 1. Backwash:** The flow through the mineral bed is reversed and allowed to flow to drain. The up-flow action washes any sediment or foreign material collected in the unit out to drain. At the same time the mineral itself is restratified, thereby eliminating any possibility of channeling (approximately 10 minutes).
- 2. Brine/Rinse:** The flow through the unit is returned to down-flow to drain at a slow controlled rate and during the first stage of this step the brine is injected to react with the mineral and restore its softening capacity. The second stage of this step is a continued slow flow of water to rinse all of the exchanged hardness and salt from the unit before its return to service (approximately 60 minutes).
- 3. Fast Flush:** The downward flow to drain in this step is increased to a high rate which will repack the mineral bed and remove the last traces of salt and hardness from the regenerated equipment just before its return to service (approximately 6 minutes).

FLOW DIAGRAM

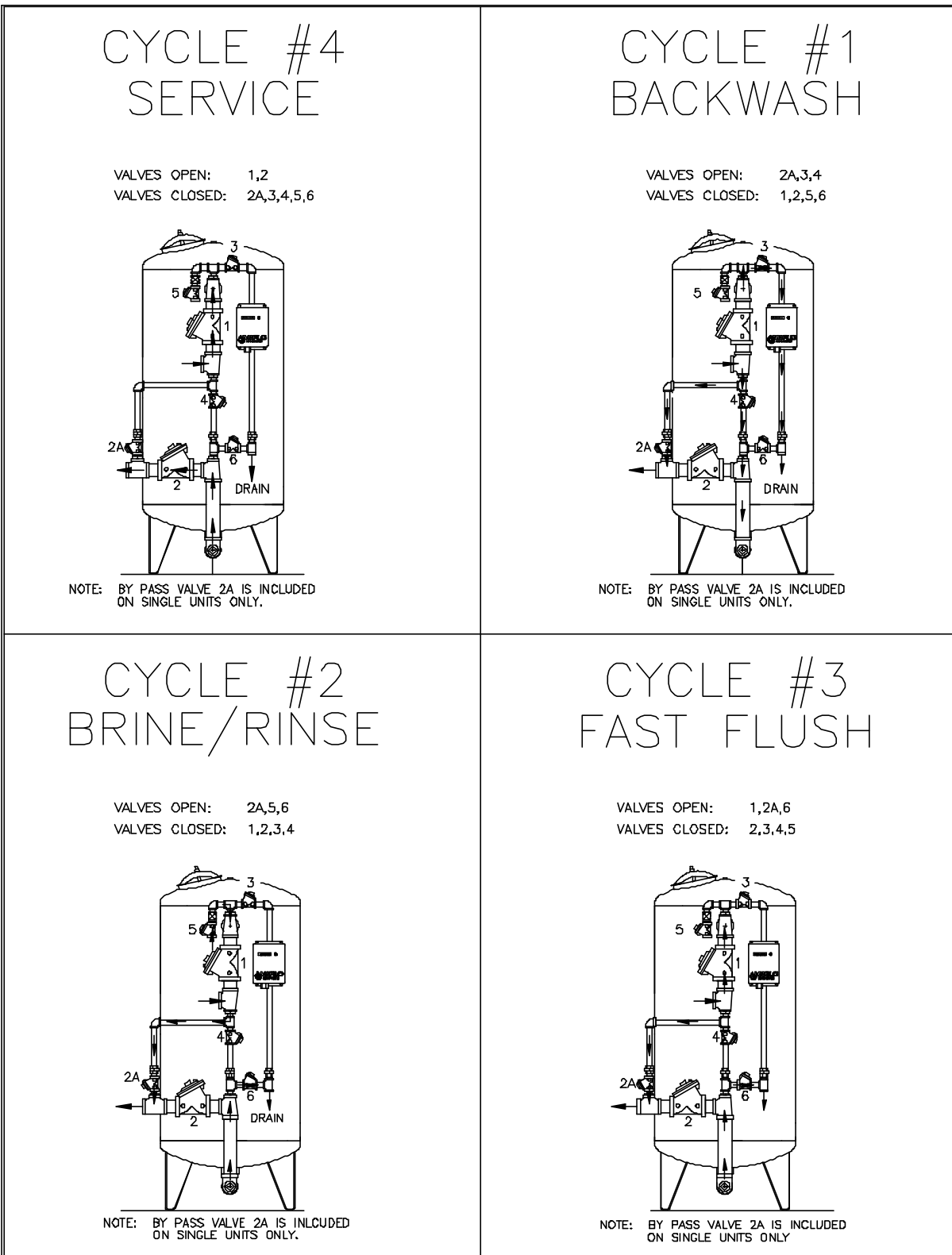

BRINE MAKER OPERATION

The brine-maker is an automatic brining system, which is easily adjusted to provide maximum operating efficiency of your water softener. It is a combination salt storage and brine-measuring tank complete with an automatic valve.

The brine-maker consists of:

1. An open brine tank with a platform dividing it into sections:
 - The upper section is used for dry salt storage
 - The lower section for brine storage.
2. An automatic brine valve which is housed in a closed tube or “well”.

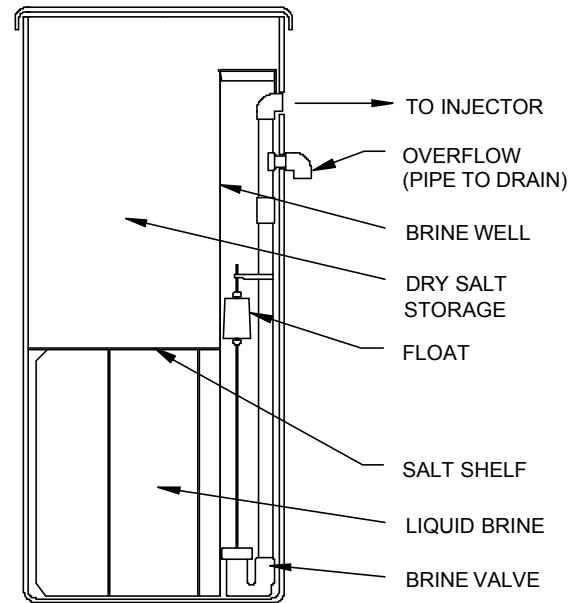

After each regeneration, water flows from the brine valve and into the brine tank. When the water level rises slightly above the platform, a float closes the automatic brine valve. Salt slowly dissolves to form concentrated brine.

As brine is formed, the liquid volume increases and the level rises in the salt. The resulting level may be 2 to 10 inches above the platform depending on the amount of salt for regeneration.

During regeneration, the brine injector creates suction, which opens the brine valve and draws into the softener tank. When the brine level falls below the brine valve, the valve seats and prevents air from entering the system.

RECOMMENDED TYPES OF SALT

Only purified salt should be used in the brining system. Palletized salt (“Button”, “Nugget”, and “Pellet”) or block salt (free binders) is recommended. Do **not** use granulated salt, as it will fall through the platform screen.

Rock salt is not normally recommended. Most rock salt contains sludge-forming insoluble that collect on the platform and prevents proper salt-water contact.

Only salt containing 0.5% or less of insolubles will provide continued satisfactory operation. If, salt with more insolubles is used, the brine maker will require periodic cleaning.

MINIMUM SALTING ADJUSTMENT

Minimum salting is the most efficient use of salt. But it does minimize the capacity of the unit, which will decrease the time between regenerations. **Only** make this adjust after the unit has completed a brine tank refill step and the water level was checked to be above the salt platform. Follow these instructions to adjust your unit to regenerate with minimum salt usage.

- Adjust brine tank refill time to the minimum setting according to the specification table. Refer to the "Setting the regeneration cycle timer page.
 - Monitor the water daily for hardness. It may also be necessary to adjust the regeneration frequency, since the capacity of the unit has changed.
1. Remove brine valve assembly from brine well.
 2. Remove air check from assembly.
 3. Shorten the riser tube by removing the top extension pipe.
 4. Reassemble brine valve assembly.
 5. Reinstall the assembly into the brine well.
The assembly will no longer reach the bottom of the brine tank.

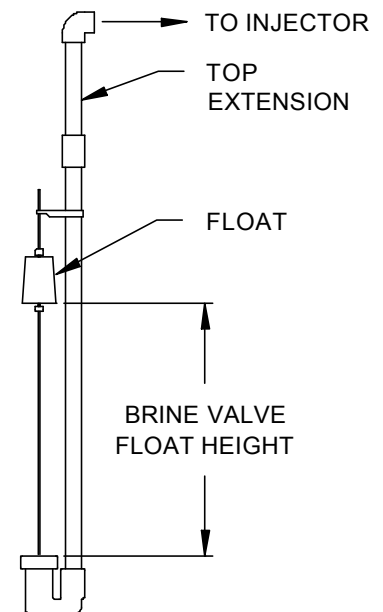

**Flow Rate Trip Point Table
Program Values for A, B, C & D**

MODEL		Alternating Operation (gpm)		Parallel Operation (gpm)			
		Second Unit Trip Flow Range		Second Unit Trip Flow Range		*Third Unit Trip Flow Range	
Exchange Capacity	Pipe Size	Min	Max	Min	Max	Min	Max
		A	B	A	B	C	D
150	1	30	40	7	30	15	60
150	1 1/4	40	60	10	40	20	80
150	1 1/2	50	80	15	50	30	100
150	2	70	100	25	70	50	140
210	1 1/4	40	60	10	40	20	80
210	1 1/2	60	90	15	60	30	120
210	2	80	120	25	80	50	160
210	2 1/2	110	160	30	110	60	220
300	1 1/2	70	100	15	70	30	140
300	2	90	130	25	90	50	180
300	2 1/2	120	190	35	140	70	280
300	3	140	230	50	160	100	320
450	1 1/2	70	90	15	60	30	120
450	2	110	120	25	80	50	160
450	2 1/2	140	170	35	120	70	240
450	3	175	190	50	140	100	280
600	1 1/2	90	100	20	70	40	140
600	2	110	130	25	110	50	220
600	2 1/2	140	190	35	140	70	280
600	3	175	250	50	175	100	350
750	2	90	120	25	90	50	180
750	2 1/2	140	190	35	140	70	280
750	3	160	230	50	160	100	320
900	2	105	140	30	105	60	210
900	2 1/2	150	220	35	150	70	300
900	3	190	280	50	190	100	380
1050	2	95	130	40	95	80	190
1050	2 1/2	145	210	45	145	90	290
1050	3	175	260	50	175	100	350

K FACTOR Table

PIPE SIZE (Inches)	Program values for XX				
	TEE Galvanized	TEE PVC	SADDLE Iron	SADDLE PVC	WELDOLET Carbon Steel
1	213	352			
1 1/4	128	177			
1 1/2	94	118			
2	59	67	54	67	
2 1/2		43	38	43	38
3		27	23	27	24
4		15	13	15	14
6			7	8	8

Seqn	Item Number	Vendor No	Qty	Description
1	A2147029	A16148CHSCFG	1	ENCLOSURE 16X14X8 FRP SCREW OVR
2	A2148010	A16P14	1	SUBPANEL 16 X 14
4	A2586066	2711R-T4T	1	PANEL VIEW PM600 COLOR TOUCH (2711R-T4T)
5	A2325005	1761-CBL-PM02	1	CABLE ASSY 1761-CBL-PM02
6	A2150200	200221 BEVADH	1	NAMEPLATE 7/8X3.25 BLANK W/TAPE WHIT
8	A2242132	41D397	1	TRANSFORMER 100VA 120V TO 24VAC (41D397)
9	A2331075	29002992	1	PURCH SUPPLY 2.5A (60M) STEP 24VDC UL(29002992)
10	A2554080	FAZ-C51-NA-SP	1	CIRCUIT BREAKER UL(CSA) 5A C CURVE(FAZ-C51-NA-SP)
12	A2331001	1762-L24BWA	1	CONTROL MICRO 1200 PLC 120V(BWA)
13	A2547010	G1X2WH6	4	DUCT WIRE 1X2 WHITE(WAS E1X2WH6)
14	A2103068	C1WH6F	4	COVER WIRE DUCT 1 WHITE
15	A2307004	1492-F2	45	BLOCK TERMINAL
16	A2318002	1492-N18	2	BARRIER TERMINAL END (1492N18)
17	A2307007	1492-N23	4	ANCHOR END TERMINAL BLOCK
18	A2307056	245-116	4	ANCHOR DIN RAIL W/REGO (245-116)
20	A2196069	1171-007	8	WASHER #6 FLAT SS
21	A2457007	72522	8	SCREW #6-32X0.8 INCH PH HD SS
22	A2394007	3444-011-W5165	2	GRIP CORD 084-210 (3444-011)
23	A2221088	CALMT150A28AG	1	VALVE SOLENOID PARKER BRASS 3-WAY 246501
24	A2595003	LAWG2-14-0Y	1	LUG GROUND ALUMI 2.14AWG 1/4 STD
25	A2130007	W169PLP-4-2	11	ELBOW W/MALE 1/4TX1/8MPT
26	A2130013	W172PLP-4-2	2	TEE BRANCH 1/4TX1/8MPT
27	A2394018	93151960	1	GRIP CORD 1/2 DIC BUSHED NIPPLE CROUSE-HINDS SDD
28	A2453007	5262	1	RING SEALING 1/2
29	A2155084	V3926-01	1	STAGER 4 POS NOTCH 2 SWITCH 24VAC
30	A2435043	RG1986-6	2	KIT SURGE SUPPRESSOR
31	A2619003	LOT PRICING - Q	4	TAB MOUNT ALUMINUM ELECTR LRG HOLE

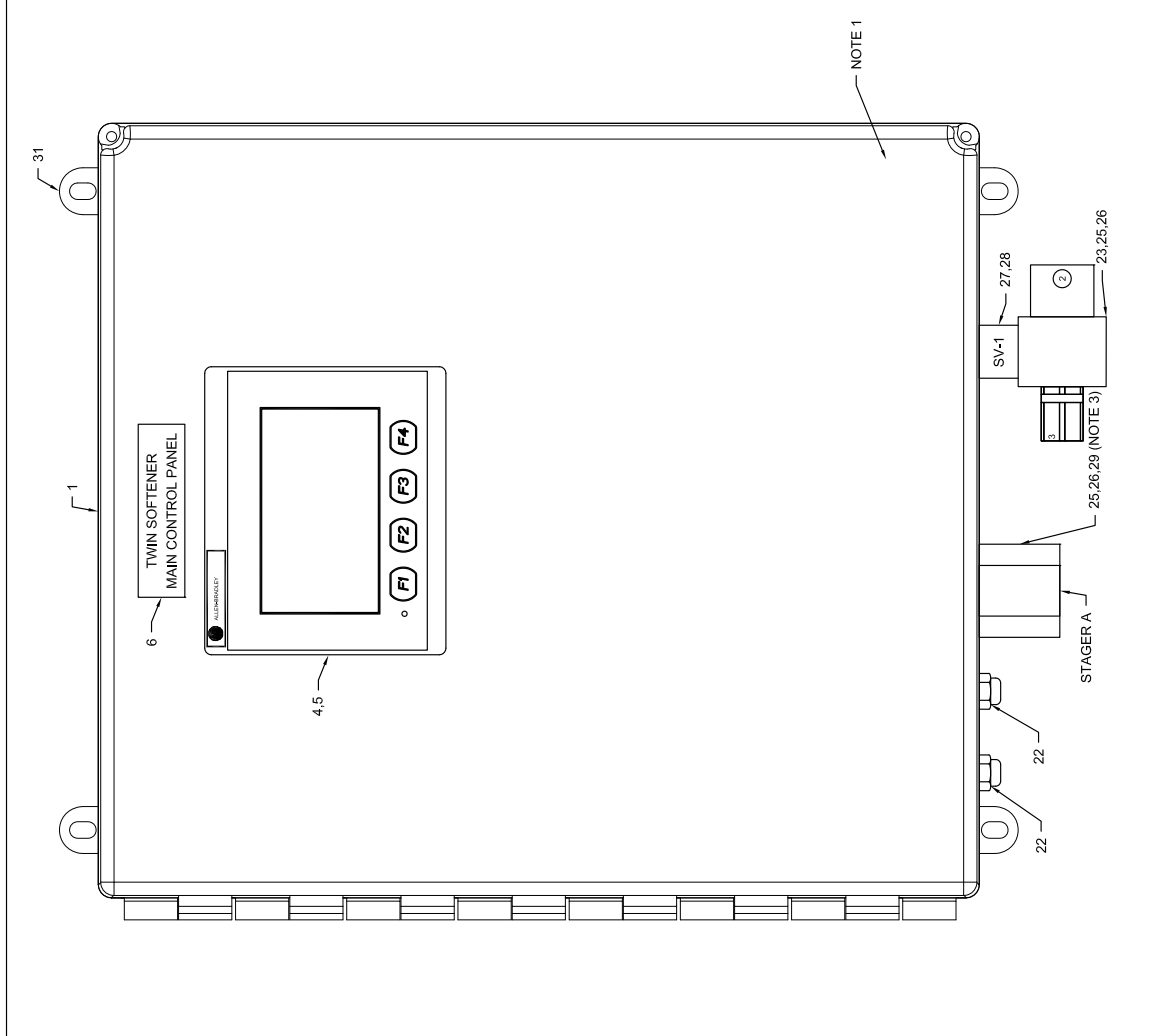

NOTE 1

NOTE: THIS PANEL DOES NOT HAVE A LAMP DISCONNECT OR BRANCH CIRCUIT PROTECTION, IT IS UP TO THE USER TO PROVIDE THIS ENCLOSURE TO ALL REQUIREMENTS.

NOTE 1

WARNING: CHECK THE PANEL AFTER ANY SERVICE THAT PENETRATES THE ENCLOSURE MUST MAINTAIN THE ELECTRICAL REQUIREMENTS.

UL ENVIRONMENTAL SYSTEMS: 1

E341514 ELECTRICAL SPECIFICATIONS

Max Line Voltage: Phase: Hg Hg

Load: Motor T-L-A T-LL T-LL

SCCR: Min Amp: Full Amp:

1. LOCATE LABEL ON INSIDE OF ENCLOSURE DOOR.
2. REFERENCE DWG. B1047200 FOR SUB-PANEL LAYOUT.
3. GROUND STAGER PLATE TO SUB-PANEL.
4. CONDUIT CONNECTIONS LOCATED IN BOTTOM OF PANEL.

STAGER TUBE FTG CHART

PORT	TYPE	SOLENOID TUBE FTG CHART
1	ELBOW	1
2	ELBOW	2
3	ELBOW	3
4	ELBOW	
5	ELBOW	
6	ELBOW	
IN	TEE	
DR	ELBOW	

REV	DATE	BY	REVISIONS

FIG. NO.	REV.	ENCLOSURE ASSEMBLY

FORM NO.	REV.	SHEET	OF

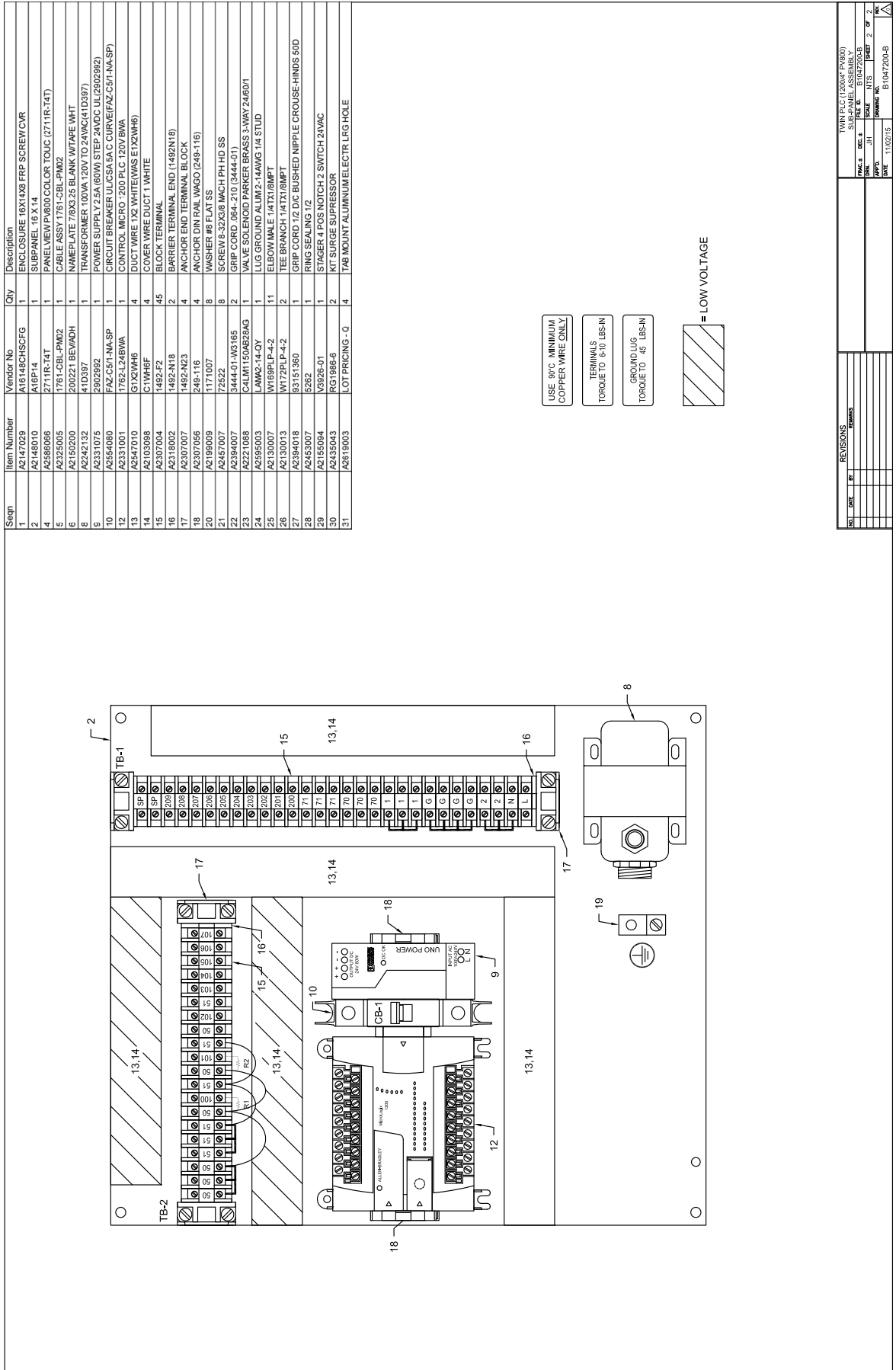

Seq#	Item Number	Vendor No	Qty	Description
1	A2147029	A16148CHSCFG	1	ENCLOSURE 16X14X8 FRP SCREW CVR
2	A2148010	A16P14	1	SUBPANEL 16 X 14
4	A2386066	2711R-14T	1	PANEL VIEW PV600 COLOR TOUCH (2711R-14T)
5	A2325005	1761-CBL-PM02	1	CABLE ASSY 1761-CBL-PM02
6	A2150200	200221 BEVADH	1	NAMEPLATE 7/8X3 25 BLANK W/TAPE WHIT
8	A2242132	41D397	1	TRANSFORMER 100VA 120V TO 24VAC(41D397)
9	A2331075	2902892	1	POWER SUPPLY 2.5A (60W) STEP 24VDC UL2902892
10	A2354080	FAZ-C51-NA-SP	1	CIRCUIT BREAKER UL/C5A 5A C CURVE(FAZ-C51-NA-SP)
12	A2341001	1782-L24BWA	1	CONTROL MICRO 2000 PLC 120V/BWA
13	A2437010	G1XVWH6	4	DUCT WIRE 1X2 WHITE(WAS E1X2VWH6)
14	A2103088	G1XVWH6	4	COVER WIRE DUCT 1 WHITE
15	A2307004	1492-F2	45	BLOCK TERMINAL
16	A2318002	1492-N18	2	BARRIER TERMINAL END (1492N18)
17	A2307007	1492-A233	4	ANCHOR END TERMINAL BLOCK
18	A2307066	246-116	4	ANCHOR DIN RAIL W/ARGO (246-116)
20	A2199009	1171007	8	WASHER #8 FLAT SS
21	A2457007	72522	8	SCREW #8 32X3/8 INCH PH HD SS
22	A2324007	3444-01-14916E	2	GRIP CORD .062 ID (3444-01)
23	A2321088	CALUM1EAB2BAG	1	VALVE SOLINOID PARKER BRASS 3/4WAY 24/60/1
24	A2355003	14M3-14-LO	1	ULC GROUND ALUM 3-14W/NG 1/4 STUD
25	A2133007	W199P14-42	11	ELBOW/MALLE 1/4TX1/8MPT
26	A2394018	W172P14-42	2	TEE BRANCH 1/4TX1/8MPT
27	A2453007	5262	1	GRIP CORD 7/2 D/C BUSHED NIPPLE CROUSE-HINDS 5/16
28	A2155094	V3265-01	1	RING SEALING 1/2
29	A2435043	RG1986-6	2	STAGER 4 POS NOTCH 2 SWITCH 24VAC
30	A2435043	RG1986-6	2	KIT SURGE SUPPRESSOR
31	A2619003		4	LOT PRICING - G

USE 80°C MINIMUM COPPER WIRE ONLY

TERMINALS TORQUE TO 6-10 LBS-IN

GROUND LUG TORQUE TO 45 LBS-IN

LOW VOLTAGE

REV	DATE	BY	REVISIONS
1			TWIN PLC (1200CF PR820)
2			SUB-PANEL ASSEMBLY
3			REV #1 B1047200-B
4			REV #2 B1047200-B
5			REV #3 B1047200-B
6			REV #4 B1047200-B
7			REV #5 B1047200-B
8			REV #6 B1047200-B
9			REV #7 B1047200-B
10			REV #8 B1047200-B
11			REV #9 B1047200-B
12			REV #10 B1047200-B
13			REV #11 B1047200-B
14			REV #12 B1047200-B
15			REV #13 B1047200-B
16			REV #14 B1047200-B
17			REV #15 B1047200-B
18			REV #16 B1047200-B
19			REV #17 B1047200-B
20			REV #18 B1047200-B
21			REV #19 B1047200-B
22			REV #20 B1047200-B
23			REV #21 B1047200-B
24			REV #22 B1047200-B
25			REV #23 B1047200-B
26			REV #24 B1047200-B
27			REV #25 B1047200-B
28			REV #26 B1047200-B
29			REV #27 B1047200-B
30			REV #28 B1047200-B
31			REV #29 B1047200-B
32			REV #30 B1047200-B
33			REV #31 B1047200-B
34			REV #32 B1047200-B
35			REV #33 B1047200-B
36			REV #34 B1047200-B
37			REV #35 B1047200-B
38			REV #36 B1047200-B
39			REV #37 B1047200-B
40			REV #38 B1047200-B
41			REV #39 B1047200-B
42			REV #40 B1047200-B
43			REV #41 B1047200-B
44			REV #42 B1047200-B
45			REV #43 B1047200-B
46			REV #44 B1047200-B
47			REV #45 B1047200-B
48			REV #46 B1047200-B
49			REV #47 B1047200-B
50			REV #48 B1047200-B
51			REV #49 B1047200-B
52			REV #50 B1047200-B
53			REV #51 B1047200-B
54			REV #52 B1047200-B
55			REV #53 B1047200-B
56			REV #54 B1047200-B
57			REV #55 B1047200-B
58			REV #56 B1047200-B
59			REV #57 B1047200-B
60			REV #58 B1047200-B
61			REV #59 B1047200-B
62			REV #60 B1047200-B
63			REV #61 B1047200-B
64			REV #62 B1047200-B
65			REV #63 B1047200-B
66			REV #64 B1047200-B
67			REV #65 B1047200-B
68			REV #66 B1047200-B
69			REV #67 B1047200-B
70			REV #68 B1047200-B
71			REV #69 B1047200-B
72			REV #70 B1047200-B
73			REV #71 B1047200-B
74			REV #72 B1047200-B
75			REV #73 B1047200-B
76			REV #74 B1047200-B
77			REV #75 B1047200-B
78			REV #76 B1047200-B
79			REV #77 B1047200-B
80			REV #78 B1047200-B
81			REV #79 B1047200-B
82			REV #80 B1047200-B
83			REV #81 B1047200-B
84			REV #82 B1047200-B
85			REV #83 B1047200-B
86			REV #84 B1047200-B
87			REV #85 B1047200-B
88			REV #86 B1047200-B
89			REV #87 B1047200-B
90			REV #88 B1047200-B
91			REV #89 B1047200-B
92			REV #90 B1047200-B
93			REV #91 B1047200-B
94			REV #92 B1047200-B
95			REV #93 B1047200-B
96			REV #94 B1047200-B
97			REV #95 B1047200-B
98			REV #96 B1047200-B
99			REV #97 B1047200-B
100			REV #98 B1047200-B
101			REV #99 B1047200-B
102			REV #100 B1047200-B

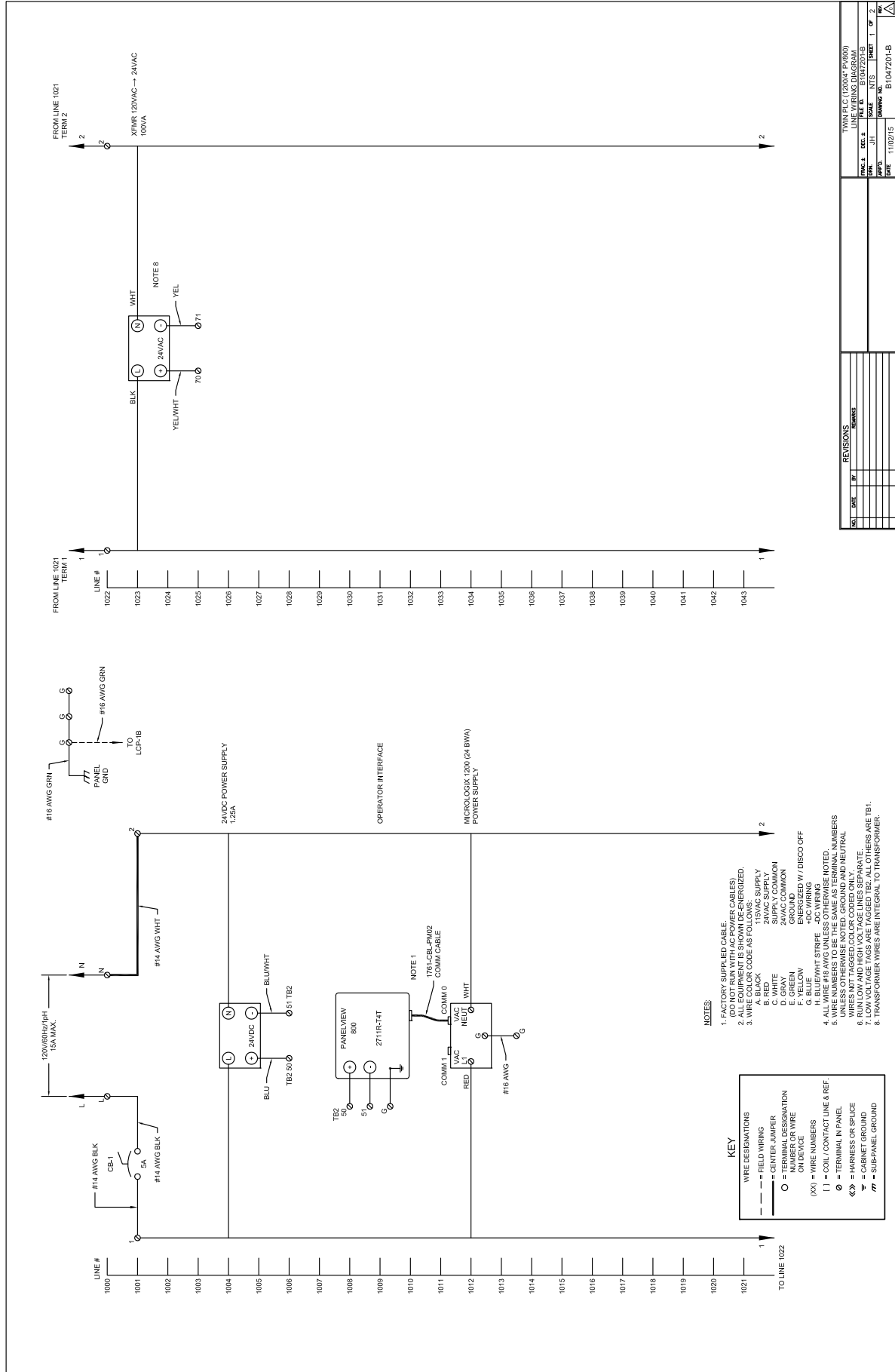

REVISIONS			
NO.	DATE	BY	DESCRIPTION
1			
2			
3			
4			
5			
6			
7			
8			
9			
10			

TITLE	MR 150M-1050M TWIN - 400C HMI PLC CONTROLLER MAINTENANCE
DATE	DEC 9 11:02:12
BY	JH
CHECKED BY	NTS
SCALE	1 OF 2
PROJECT	B1047201-B
DRAWING	B1047201-B

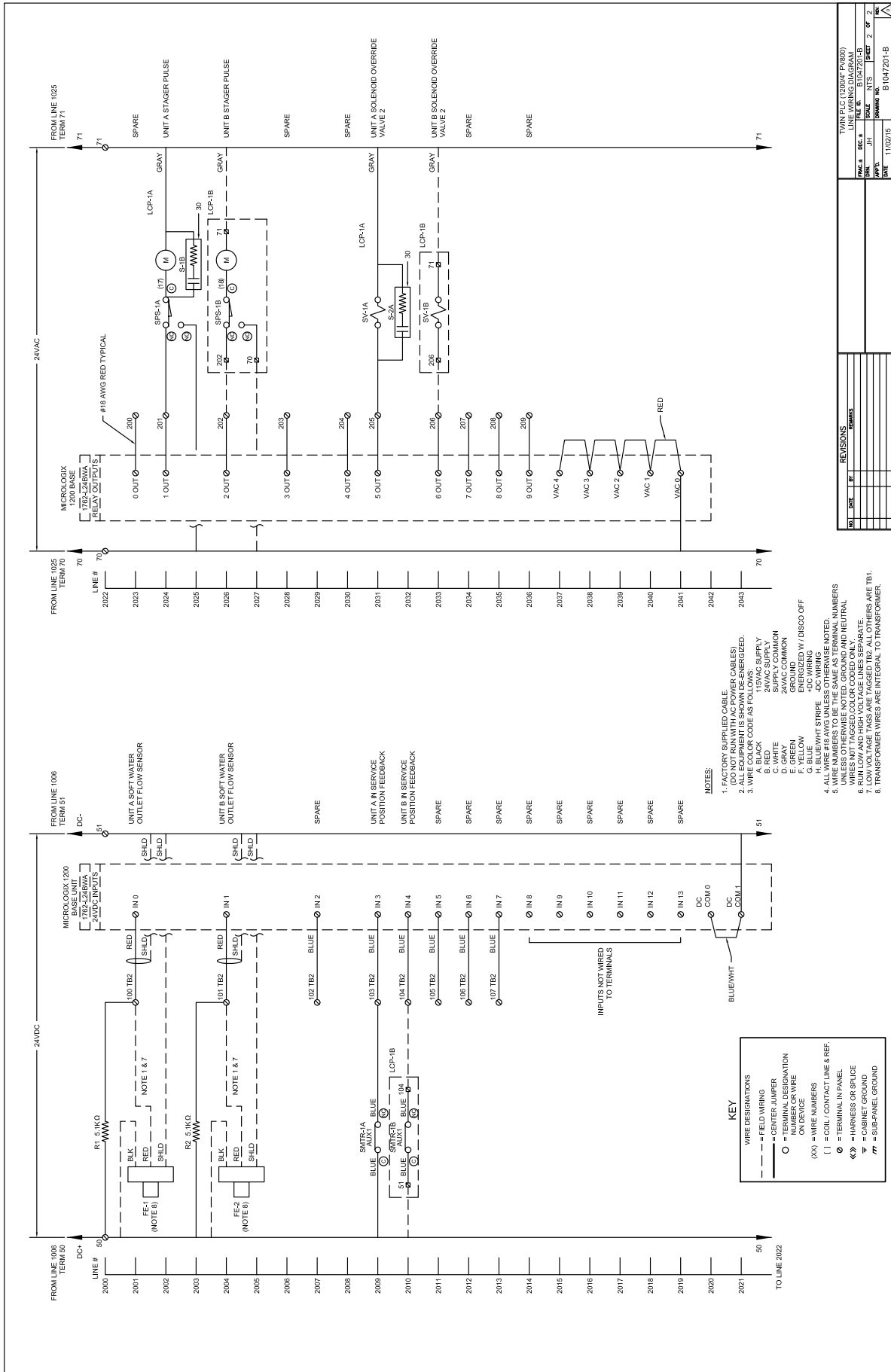

Seqn	Item Number	Vendor No	Description	Qty
1	A2147021	A1086CHSCFG	ENCLOSURE 10X8X6 NEMA4X	1
2	A2150201	200221	NAMEPLATE 7/8X3/25 BLANK NOTAPE WHT	1
3	A2435043	RG1986-6	KIT SURGE SUPPRESSOR	2
4	A2155094	V6926-01	STAGER 4 POS NOTCH 2 SWITCH 24VAC	1
5	A2130007	W169PL P-4-2	ELBOW/MALE 1/4TX1/8MPT	11
6	A2445043	265-361	PLATE END W/FRING FLANGE	2
7	A2146003	A10PB	SUBPANEL 10 X 6	1
8	A2221088	C4LM1504B28AG	VALVE SOLENOID PARKER BRASS 3-WAY 2460T(C4LM1504B28AG)	1
9	A2130013	W172PI P-4-2	TEE BRANCH 1/4TX1/8MPT	2
10	A2384018	83151360	GRIP CORD 1/2 D.C BUSHED NIPPLE CROUSE-HINDS 50D	1
11	A2453007	6262	RING SEALING 1/2	1
12	A2150202	200221	NAMEPLATE .50X.75 BLANK NO TPE WHT	1
13	A2307015	260-331	TERMINAL BLOCK MODULAR GREY	7
14	A2307016	260-337	TERMINAL BLOCK MODULAR GREEN	1
15	A2173014	MTW19BX3500	WIRE MTW18 STRANDED BLUE(2500 RL)	3
15	A2173003	MTW18GN	WIRE MTW18 STRANDED GREEN	1
16	A2619003	LOT PRICING - Q	7/8" MOUNT ALUMINUM ELECTR LRG HOLE	4

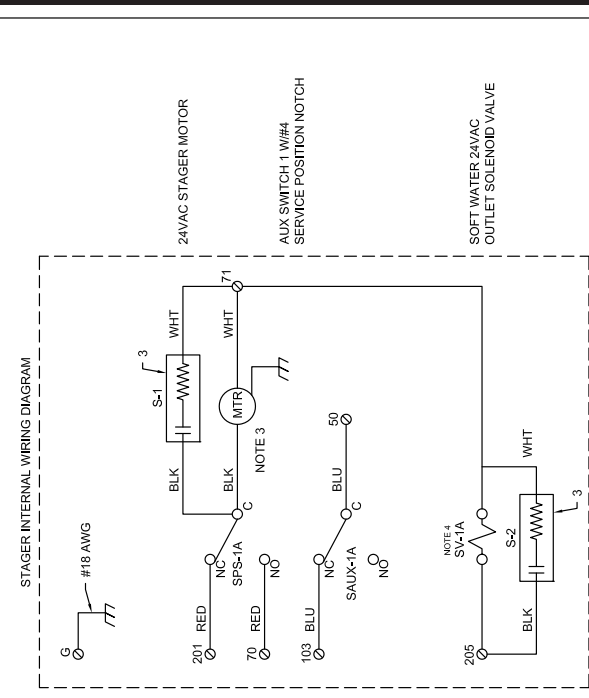
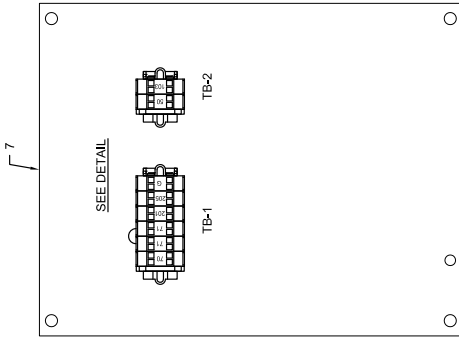
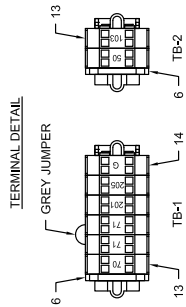

- NOTES:**
1. ALL WIRE #18 AWG UNLESS OTHERWISE NOTED.
 2. SPS-1A = STAGER PULSE SWITCH
SAUX-1A = STAGER AUXILIARY SWITCH 1 IN SERVICE #4 STEP
 - MTR = STAGER MOTOR
SV = SOLENOID VALVE
S-1,2 = SURGE SUPPRESS
 3. GROUND STAGER MOTOR TO PANEL.
 4. WIRES ARE INTEGRAL TO SOLENOID.

STAGER TUBE FTG CHART

PORT	TYPE	PORT	TYPE
1	ELBOW	1	ELBOW
2	ELBOW	2	ELBOW
3	ELBOW	3	ELBOW
4	ELBOW		
5	ELBOW		
6	ELBOW		
IN	TEE		
DR	ELBOW		

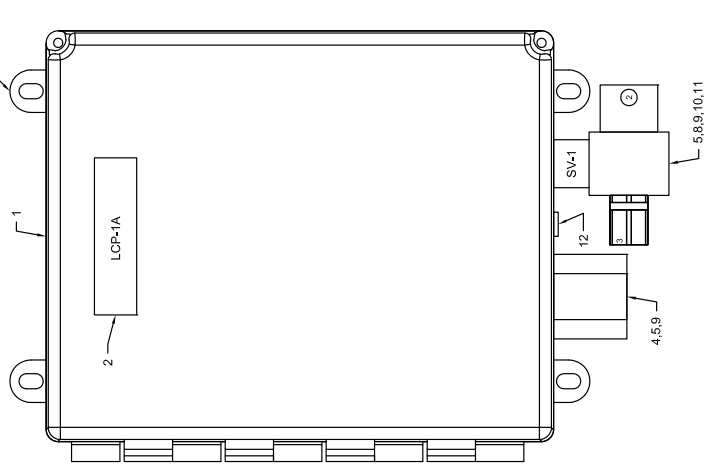

REV	DATE	BY	REVISIONS

UNIT	UNIT 1 STAGER LCP-1A
WIRING DIAGRAM & ASSEMBLY	
REV. #	B1048150-B
DATE	11/02/15
APP'D.	JH
DRAWING NO.	B1048150-B
PAGE	1 OF 1

ITEM	PART NO	DESCRIPTION	QTY
1	A2147001	ENCLOSURE, 6 X 6 X 4	1
2	A2150007	NAMEPLATE (RIGHT UNIT)	1
3	A2150001	NAMEPLATE (MARLO)	1
4	B1045003	STAGER ASSY W/POSITION & AUX SWITCH	1
5	A2130007	TUBE FTG, BRASS, ELBOW, 1/4T X 1/8MPT	6
6	A2130001	TUBE FTG, BRASS, MALE CONN, 1/4T X 1/8MPT	2
7	A2148001	SUBPANEL, 6 X 6	1
8	A2152003	TERMINAL STRIP, 6 POINT	1
9	A2153003	TERMINAL STRIP MARKER, 6 POINT	1

TUBE FTG CHART

PORT	TYPE
1	ELBOW
2	ELBOW
3	ELBOW
4	ELBOW
5	ELBOW
6	ELBOW
IN	MALE CONN
OUT	MALE CONN

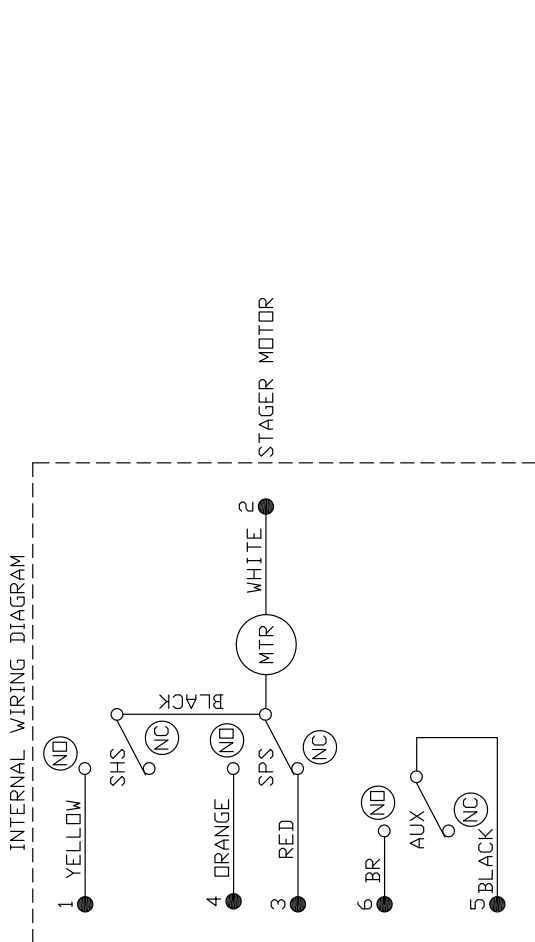

SHS = STAGER HOMING SWITCH (MIDDLE)
 SPS = STAGER POSITION SWITCH (BOTTOM)
 AUX = STAGER AUXILIARY SWITCH
 SWITCHES SHOWN IN #4 (SERVICE) CYCLE

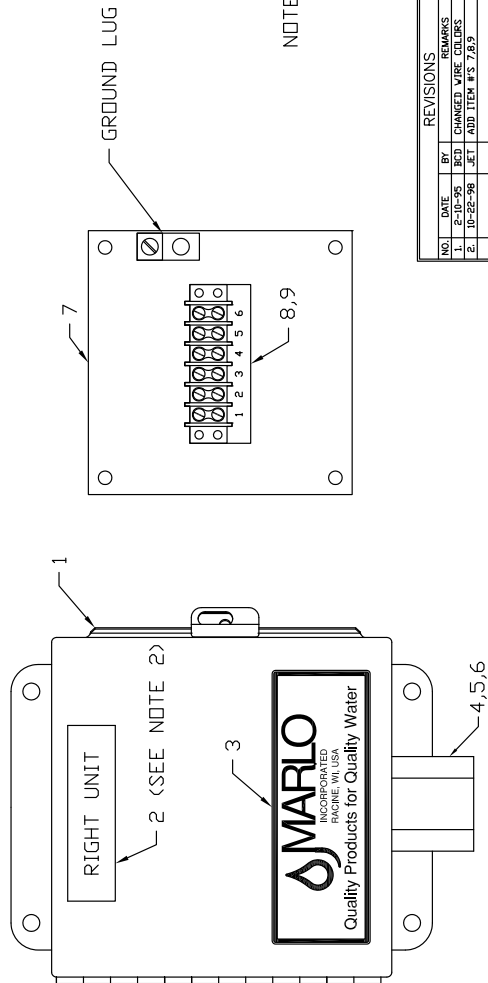

- NOTES:**
- AUX SWITCH TO ACTUATE DURING #2 CYCLE.
 - CHANGE NAMEPLATE AS REQUIRED TO MATCH UNIT LOCATION.

REVISIONS		REMARKS	
NO.	DATE	BY	REASON
1	2-10-95	BJD	CHANGED WIRE COLORS
1	10-26-95	SET	ADD TIEB #S 7&8

REMOTE STAGER ASSEMBLY	
W/ POSITION, HOME & AUX SWITCHES	FILE ID: B1048010
FRAC.#	DEC.#
DRN.	BCD
APP'D.	JET
SCALE	N.T.S.
DRAWING NO.	SHEET 1 OF 1
DATE 10-26-95	DRAWING NO. B1048010

4 POSITION STAGER	
AUX SWITCH ACTIVATED DURING STEP #2	

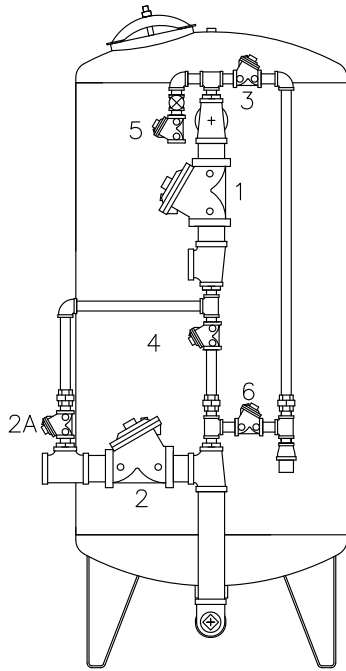

Replacement Valve Table

Location#	Function	Position
1	Service Inlet	NORMALLY OPEN
2	Service Outlet	NORMALLY OPEN
2A	Bypass Valve - Single Systems Only	NORMALLY CLOSED
3	Backwash Outlet	NORMALLY OPEN
4	Backwash Inlet	NORMALLY OPEN
5	Brine Inlet	NORMALLY OPEN SPRING ASSIST OPEN
6	Brine/Flush Outlet	NORMALLY OPEN SPRING ASSIST OPEN

Valve 2A - Is Used on Single Systems Only

MR Model	Pipe Size	Valve 1	Valve 2	Valve 2A	Valve 3	Valve 4	Valve 5	Valve 6
150	1	B2010102B	B2010202B	A2009001B	A2010001B	B2010201B	A2007001B	A2007001B
	1.25	B2010103B	B2010203B	A2009001B	A2010001B	B2010201B	A2007001B	A2007001B
	1.5	B2010104B	B2010204B	A2009001B	A2010001B	B2010201B	A2007001B	A2007001B
	2	B2010105B	B2010205B	A2009001B	A2010001B	B2010201B	A2007001B	A2007001B
210	1.25	B2010103B	B2010203B	A2009001B	A2010001B	B2010201B	A2007001B	A2007001B
	1.5	B2010104B	B2010204B	A2009001B	A2010001B	B2010201B	A2007001B	A2007001B
	2	B2010105B	B2010205B	A2009001B	A2010001B	B2010201B	A2007001B	A2007001B
	2.5	B2010107B	B2010207B	A2009001B	A2010001B	B2010201B	A2007001B	A2007001B
300	1.5	B2010104B	B2010204B	A2009001B	A2010001B	B2010201B	A2007001B	A2007001B
	2	B2010105B	B2010205B	A2009001B	A2010001B	B2010201B	A2007001B	A2007001B
	2.5	B2010107B	B2010207B	A2009001B	A2010001B	B2010201B	A2007001B	A2007001B
	3	B2010108B	B2010208B	A2009001B	A2010001B	B2010201B	A2007001B	A2007001B
450	1.5	B2010104B	B2010204B	A2009001B	A2010001B	B2010201B	A2007001B	A2007001B
	2	B2010105B	B2010205B	A2009001B	A2010001B	B2010201B	A2007001B	A2007001B
	2.5	B2010107B	B2010207B	A2009001B	A2010001B	B2010201B	A2007001B	A2007001B
	3	B2010108B	B2010208B	A2009001B	A2010001B	B2010201B	A2007001B	A2007001B
600	1.5	B2010104B	B2010204B	A2009002B	A2010002B	B2010202B	A2007002B	A2007002B
	2	B2010105B	B2010205B	A2009002B	A2010002B	B2010202B	A2007002B	A2007002B
	2.5	B2010107B	B2010207B	A2009002B	A2010002B	B2010202B	A2007002B	A2007002B
	3	B2010108B	B2010208B	A2009002B	A2010002B	B2010202B	A2007002B	A2007002B
750	2	B2010105B	B2010205B	A2009002B	A2010002B	B2010202B	A2007002B	A2007002B
	2.5	B2010107B	B2010207B	A2009002B	A2010002B	B2010202B	A2007002B	A2007002B
	3	B2010108B	B2010208B	A2009002B	A2010002B	B2010202B	A2007002B	A2007002B
900	2	B2010105B	B2010205B	A2009002B	A2010003B	B2010203B	A2007002B	A2007002B
	2.5	B2010107B	B2010207B	A2009002B	A2010003B	B2010203B	A2007002B	A2007002B
	3	B2010108B	B2010208B	A2009002B	A2010003B	B2010203B	A2007002B	A2007002B
1050	2	B2010105B	B2010205B	A2009002B	A2010003B	B2010203B	A2007002B	A2007002B
	2.5	B2010107B	B2010207B	A2009002B	A2010003B	B2010203B	A2007002B	A2007002B
	3	B2010108B	B2010208B	A2009002B	A2010003B	B2010203B	A2007002B	A2007002B

Valve 1 is Drilled and Tapped with 1/4" Female Thread on Boss #1

Valve 2 and 4 are Drilled and Tapped with 1/4" Female Thread on Boss #2

AQUAMATIC REPAIR KITS

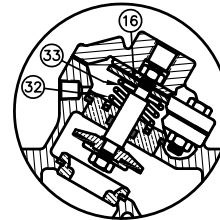
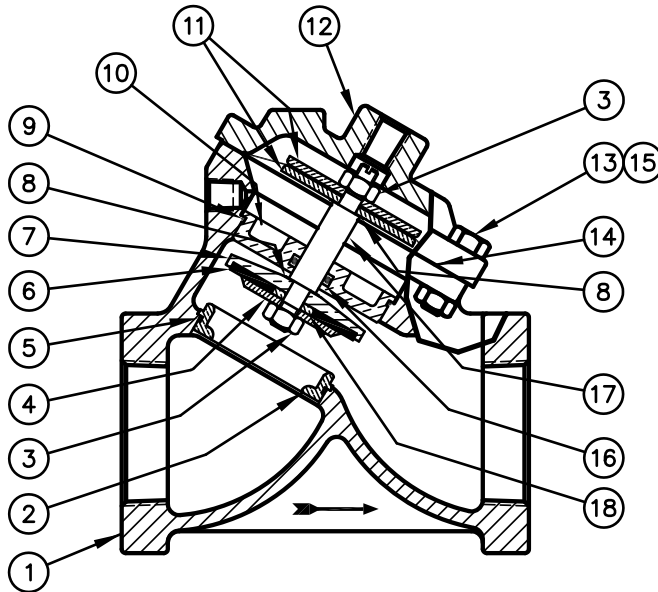

SPRING ASSIST OPEN

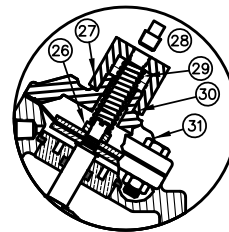

SPRING ASSIST CLOSED

- RA - Diaphragm & Seal Kits - Includes Buna N Seals and Diaphragm (Items 3(2),5,6,8(2),9,14&16)
- RF - Metal Parts Kit (Normally Open) - (Items 4,7,10,11(2), 17)
- RG - Metal Parts Kit (Normally Closed) - (Items 4,7,10,11(2), 23)
- SC - Repair Kit (Spring Assist Closed) - (Items 24,27,28)
- SO - Repair Kit (Spring Assist Open) - (Items 8,31,32)
- GT - Tool - To Install & Remove O-Ring Retainer (Not Shown)

VALVES		REPAIR KITS						SHAFTS	
VALVE SIZE	CASTING #	RA	RF	RG	SC	SO	GT	NO	NC
3/4"	421	A2089028	A2089071	A2089078	A2089085	A2089092	A2089098	A2137001	A2137008
1"	421	A2089028	A2089071	A2089078	A2089085	A2089092	A2089098	A2137001	A2137008
1 1/4"	424	A2089029	A2089072	A2089079	A2089086	A2089093	A2089099	A2137002	A2137009
1 1/2"	424	A2089029	A2089072	A2089079	A2089086	A2089093	A2089099	A2137002	A2137009
2"	425	A2089030	A2089073	A2089080	A2089087	A2089094	N/A	A2137003	A2137010
2 1/2"	426	A2089031	A2089074	A2089081	A2089088	A2089095	N/A	A2137004	A2137011
3"	427	A2089032	A2089075	A2089082	A2089089	A2089096	N/A	A2137005	A2137012
3" FLGD	427	A2089032	A2089075	A2089082	A2089089	A2089096	N/A	A2137005	A2137012
4" FLGD	428	A2089033	A2089076	A2089083	A2089090	A2089097	N/A	A2137006	A2137013
6" FLGD	429	A2089034	A2089077	A2089084	A2089091	N/A	N/A	A2137007	A2137014

2536 Standard Mount Sensor

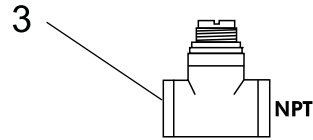
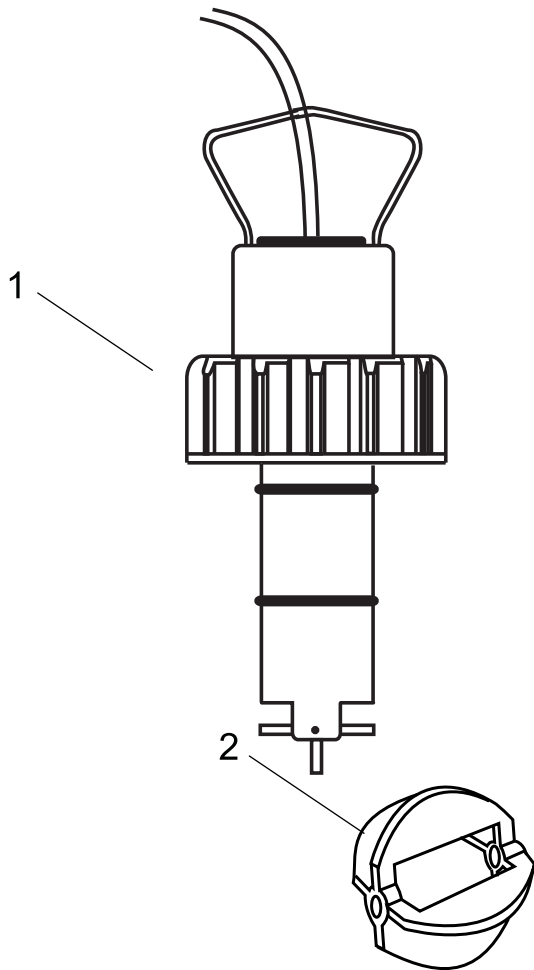

**Galvanized Iron Threaded Tee
with NPT Threads
PVDF Insert**

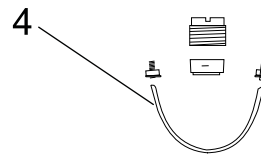

**Iron Strap-on Saddle with
PVDF Insert**

K- Factor Table

Pipe Size Inches	(Pulses per Gallon)	
	Tee Galvanized	Saddle Iron
1	213	
1-1/4	128	
1-1/2	94	
2	59	54
2-1/2		38
3		23

Item Number	Part Number	Description
1	A2296001	FLOW SENSOR
2	A2456004	ROTOR/PADDLE
3	A2294012	TEE INSTALL 1 GALV
	A2294002	TEE INSTALL 1-1/4 GALV
	A2294003	TEE INSTALL 1-1/2 GALV
	A2294004	TEE INSTALL 2 GALV
4	A2295001	SADDLE 2-1/2 IRON
	A2295002	SADDLE 3 IRON

BRINE SYSTEM FOR MGT 150-450

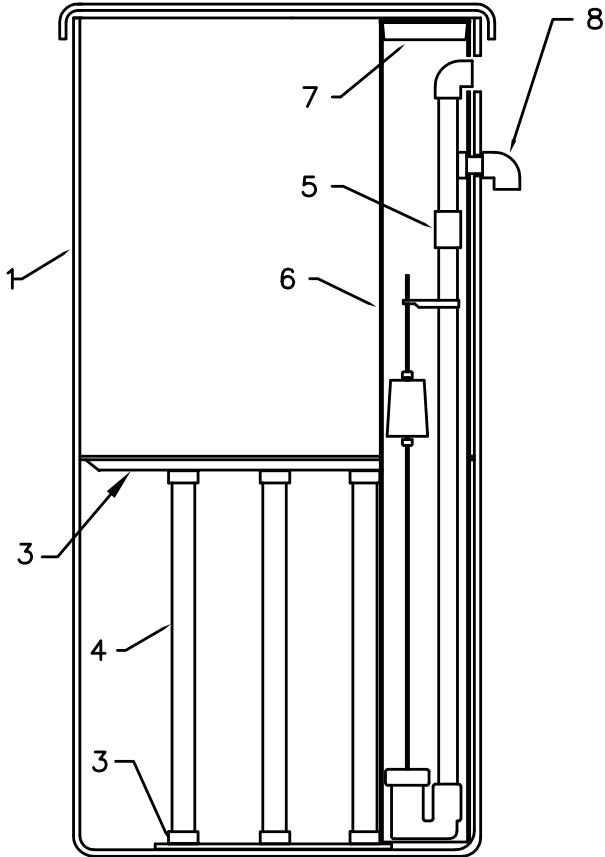

Models	Part Number	Shelf Height
MR 150	B1039001	15"
MR 210	B1039002	22"
MR 300	B1039003	29"
MR 450	B1039009	29"

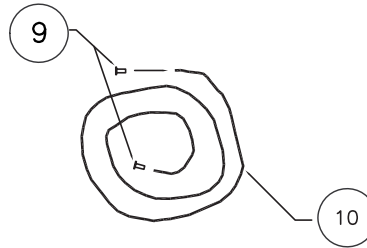

Item Number	Part Number	Item Description
1	B1002007	BRINE TANK W/HOLES 24x50-MR 150-210
	B1002008	BRINE TANK W/HOLES 24x60-MR 300
	B1002009	BRINE TANK W/HOLES 39x60-MR 450
3	A2284007	GRID PLATE PLASTIC 24DIA 5BW
	A2284010	GRID PLATE PLASTIC 30DIA 5BW
4	A2275007	PIPE 1-1/2 SDR OR SCH40 DWV
5	B1042001	BRINE VALVE ASSEMBLY-MR 150
	B1042002	BRINE VALVE ASSEMBLY-MR 210
	B1042003	BRINE VALVE ASSEMBLY-MR 300-450
6	B1015008	BRINE WELL 5x46 DRILLED
7	A2072001	CAP PLUG RED 5 INCH
8	A21200002	ELBOW OVERFLOW 1/2" W/NUT
9	A2476001	INSERT 1/2 POLY
10	A2165002	TUBING 1/2x3/8 BLACK POLY

BRINE SYSTEM FOR MGT 600-1050

39", 42" & 50" TANK DIAMETERS

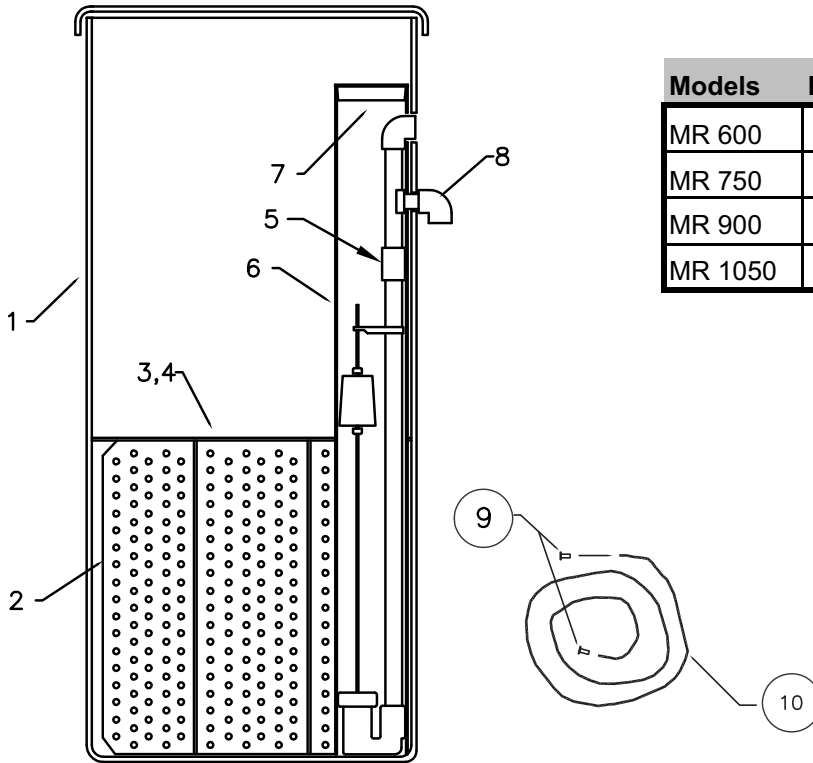

Models	Part Number	Shelf Height
MR 600	B1039005	22"
MR 750	B1039005	22"
MR 900	B1039007	29"
MR 1050	B1039008	22"

Item Number	Part Number	Item Description
1	B1002010	BRINE TANK W/HOLES 39x60 - (MR 600-750)
	B1002011	BRINE TANK W/HOLES 42x60 - (MR 900)
	B1002012	BRINE TANK W/HOLES 50x60 - (MR 1050)
2	B1043010	GRID SUPPORT SET 39" DIA, 22" HT - (MR 600-750)
	B1043011	GRID SUPPORT SET 42" DIA, 29" HT - (MR 900)
	B1043014	GRID SUPPORT SET 50" DIA, 22" HT - (MR 1050)
3	B1041003	SALT SHELF 38-1/8" DIA - (MR 600-750)
	B1041004	SALT SHELF 41-1/4" DIA - (MR 900)
	B1041005	SALT SHELF 49" DIA - (MR 1050)
4	B1040003	SALT SCREEN 39" DIA. - (MR 600-750)
	B1040004	SALT SCREEN 42" DIA. - (MR 900)
	B1040005	SALT SCREEN 50" DIA. - (MR 1050)
5	B1042002	BRINE VALVE ASSY 22" GRID - (MR 600,750,1050)
	B1042003	BRINE VALVE ASSY 29" GRID - (MR 900)
6	B1015008	BRINE WELL 5x46 DRILLED
7	A2250003	ELBOW OVERFLOW 1/2" W/NUT
8	A2072001	CAP PLUG RED 5"
9	A2476001	INSERT 1/2" POLY
10	A2165002	TUBING 1/2"x3/8" BLACK POLY

SERVICE CHART STAGER CONTROLLER

SYMPTOM	PROBABLE CAUSE	HOW TO CORRECT
Softener does not regenerate.	1. No electrical power.	Check circuit. Start a regeneration with Manual Regeneration Lever.
	2. Frequency levers on Time Dial not set properly.	Refer to “How to Set Regeneration Cycle Program 3200 Series Mechanical Timer”.
	3. Faulty timer mechanism or defective timer motor.	Replace.
	4. Defective stager drive motor.	Replace
	5. Defective micro-switch in stager drive assembly.	Replace drive assembly.
Softener regenerates as wrong time.	6. Interrupted electrical power. Time dial set improperly	Reset Time Dial to correct time. Refer to “How to Set Cycle Controller”.
Position dial does not rotate.	7. Stager drive motor burned out.	Replace.
	8. Loose Electrical connections.	Repair.
	9. Jammed stager valve.	Replace.
Softener Diaphragm Valves end regeneration cycle in wrong position.	10. Controller out of sequence due to: A. Turning position dial manually when time switch is not in “OFF” position or turning the cycle adjustment knob too quickly for stager to index.	With time switch mechanism in normally “OFF” position, (Red arrowhead pointing straight down), manually turn Position Dial clockwise to No. 4 “Service” position.
	B. Temporary low voltage condition of poor electrical connection.	Check circuitry.
	C. Jammed Stager.	Replace.
	D. Defective time switch assembly.	Replace.
	E. Defective time switch assembly.	Replace.
	F. Defective drive motor.	Replace.
Leak to drain from stager valve during service.	11. Leaky or cut seal in stager valve.	Replace.
Hardness Leakage or Improper cycling or valves. Individual valves not being pressurized or vented correctly.	12. Faulty seal in stager valve.	Replace.
	13. Clogged stager strainer.	Clean strainer.
	14. Clogged or kinked stager tubing.	Replace tubing or clean.

SERVICE CHART WATER SOFTENERS

IMPORTANT: Many softener complaints result from oversights (poor electric connections, out of salt, regenerating at wrong hour etc.) rather than from a mechanical failure. Troubleshooting guide for the MX controller is located in the back of this manual page 33.

PROBLEM OR SYMPTOM	CHECK PROCEDURE	CAUSE
Slight leak to drain.	1. Disconnect tubing at backwash control.	Flow from indicates leaky seal in stager valve.
	2. If stager is not leaking, use soap test kit and check hardness of water at drain.	If water tests soft, Valve #6 is leaking: If hard, Valve #3. See procedures 10, 11, 12 and 13.
High flow to drain during service	3. Check position dial.	If not in position #4, rotate clockwise to this position.
	4. If position dial is in position #4, check for water leakage from Valve #3 or #6 vent holes.	Leakage indicates: 1. Ruptured diaphragm. 2. Loose diaphragm nut.
	5. If vent hole is not leaking, use soap test kit and check hardness of water at drain.	If water tests soft, Valve #6 is open: If hard, Valve #3. See procedures 10, 12 and 13.
Failure to draw brine	6. Check that manual brine valve is open wide.	Valve must be open at all times, except when servicing.
	7. Check water pressure	Water pressure must be a least 30 psi during regeneration.
	8. Turn position dial clockwise to position #2. Break union in suction line to injector and feel for suction.	If there is suction, automatic brine valve may be clogged. No suction indicates: 1. Drain pipe to small or discharging at level too high above floor. 2. Plugged pilot strainer. 3. Plugged injection nozzle. 4. Valve #1, #4, or #2 not closing fully. See items 10, 11 and 13. 5. Plugged backwash controller. 6. Dirty mineral bed.
Slight leak from vent hole.	9. Turn position dial clockwise to a position, which relieves pressure on valve.	If leaking stops leak results from loose diaphragm nut, small Tear in diaphragm or special washer under diaphragm is missing. If leaking does not stop, shaft guide O-ring is damaged, shaft guide is not seated against gasket or shaft is damaged.
Diaphragm valve does not close.	10. Check that vent hole is not plugged.	If vent hole is plugged, air in space between diaphragm and shaft guide will compress and prevent valve from closing.
	11. Check for water leak at vent hole.	See Procedure 9.
	12. Loosen tubing nut at diaphragm cap.	If there is not flow, pilot strainer may be plugged.
	13. Turn off water pressure and disassemble diaphragm valve.	1. Seat washer may be dirty, worn or loose. 2. Seat may be eroded.

SERVICE CHART WATER SOFTENERS continued

PROBLEM OR SYMPTOM	CHECK PROCEDURE	CAUSE
Diaphragm valve does not open.	14. Check that vent hole is not plugged.	If vent hole is plugged, a partial vacuum will be created in the space between the diaphragm and shaft guide, preventing valve from opening.
	15. Loosen tubing nut at diaphragm cap.	1. If there is flow, stager valve is leaking. 2. If there is no flow, tubing fitting may be plugged.
Hard water leakage into service lines.	16. Close inlet and outlet valves and inspect by-pass valve.	1. Seat washer may be loose or worn. 2. Seat may be rough. 3. Shaft orifice plugged. 4. Diaphragm ruptured.
	17. Check that valve #4 is seating.	See Procedures 9, 10, 12 and 13.
Restricted or not drain flow during backwash.	18. Either valve #1 or valve #2 is not opening fully. To determine which one: Turn position dial to position #1 and then to position #3. Compare flow at drain.	Flow should be the same for both positions. 1. If no difference is noted, valve #4 is not opening properly. 2. If backwash flow is higher, valve #1 is not opening properly. See procedures 14 and 15.
Restricted or no drain flow during backwash.	19. Turn position dial to position #1 and then position #3. Compare flow at drain.	Flow should be the same. If flow for position also is low. 1. Inlet water pressure may be low. 2. Backwash flow control may be plugged. If position #3 flow rate is higher, either valve #4 or valve #3 is not opening. See procedures 14 and 15.
Losses of softening resin (evidence of resin in drain lines).	20. Open vent in top of softener tank and check for air in tank.	1. If air is present, vent completely and recheck prior to next regeneration. 2. If recheck discloses a recurring build-up of air, check brine system(s) for possible leaks in suction line or brine valve not seating properly. 3. If brine system is functioning properly source of air may be the water supply to unit. Use of an automatic air relief vane is indicated in this situation (consult factory for recommendation).
	21. Check automatic backwash control valve for rate of flow in excess of listed flow (gpm).	Check for excessive inlet water supply pressures – reduce to rated pressure.
Losses of softening resin (evidence of resin and/or gravel in service lines).	22. Check for damage to softener under-drain system.	Investigation of damage to under-drain generally requires unloading of softener tank. Consult factory for recommended procedures before proceeding.

NOTES



MR 150M–1050M TWIN - 400C HMI PLC CONTROLLER

NOTES



2227 South Street • P.O. Box 044170 • Racine, WI 53404-7003 • www.Marlo-Inc.com